

Fluorolog[®]-3



Operation Manual

Rev. 2.2 July 2002

<http://www.isainc.com>

In the USA:

Jobin Yvon Inc.
3880 Park Avenue, Edison, NJ 08820
Tel: 1-732-494-8660
Fax: 1-732-549-5157
E-Mail: fluorescence@jyhoriba.com
1-800-533-5946

In France:

16-18, rue du Canal
91165 Longjumeau cedex
Tel: (33) 1/64.54.13.00
Fax: (33) 1/69.09.93.19

Japan: (81) 3/5823.0140

China: (86) 10/6836.6542

Germany: (49) 89/46.23.17-0

Italy: (39) 2/57.60.47.62

U.K.: (44) 208/2048142



Copyright © 2002 by Jobin Yvon Inc.

All rights reserved. No part of this work may be reproduced, stored, in a retrieval system, or transmitted in any form by any means, including electronic or mechanical, photocopying and recording, without prior written permission from Jobin Yvon Inc. Requests for permission should be requested in writing.

Information in this manual is subject to change without notice, and does not represent a commitment on the part of the vendor.

July 2002

Part Number 81105

Table of Contents

0: Introduction	0-1
About the Fluorolog [®] -3.....	0-1
Chapter overview.....	0-2
Symbols used in this manual.....	0-4
1: Requirements & Installation	1-1
Surface requirements	1-1
Environmental requirements.....	1-2
Electrical requirements	1-3
Installation.....	1-4
2: System Description	2-1
Overview	2-1
Configurations.....	2-3
3: System Operation	3-1
Turning on the system	3-1
Checking system performance	3-3
Notes on excitation and emission recalibration	3-19
Useful materials for characterizing system and samples	3-20
4: Optimizing Data Acquisition.....	4-1
Cuvette preparation	4-1
Sample preparation	4-2
Data collection techniques.....	4-3
Correcting data	4-18
5: System Maintenance	5-1
Lamp.....	5-1
Emission signal detector.....	5-14
Reference signal detector.....	5-15
Gratings	5-16
Mirrors.....	5-20
Automated 4-position turret	5-21
6: Components & Accessories	6-1
Itemized list.....	6-2
Model 1940 absorption/transmission accessory.....	6-3
FL-1013 Liquid nitrogen Dewar assembly	6-6
Model 1908MOD scatter block assembly	6-7
Model 1908 standard lamp assembly	6-7
Sample cells.....	6-8
Model 1967 Photodiode reference detector	6-9
CCD detectors	6-10
Model 1911F room temperature signal detector.....	6-11
Model 1914F thermoelectrically cooled signal detector.....	6-12
FL-1030 thermoelectrically cooled near-IR photomultiplier tube	6-13
F-3000 fiber optic mount.....	6-14
Model 1938 cut-on filter	6-15
Model 1939 cut-on filter	6-15
FI-1001 Front-face viewing option	6-16
Gratings	6-17
FL-1010 cut-on filter holder.....	6-18
FL-1011 four-position thermostatted cell holder	6-19

FL-1012 dual-position thermostatted cell holder	6-21
Model 1933 solid sample holder.....	6-23
FL-1039 xenon lamp housing	6-25
FL-1040 dual lamp housing	6-25
F-3005/6 autotitration injector.....	6-26
Models F-3001, F-3002, and F-3003 microscope interfaces	6-27
Model 1907 450-W xenon lamp.....	6-28
F-3004 sample heater/cooler Peltier thermocouple drive.....	6-29
Phosphorimeter accessory	6-30
MicroMax microwell plate reader.....	6-31
FL-1044 L-format polarizer & FL-1045 T-format polarizer.....	6-32
FL-1015 injector port.....	6-33
F-1000/1 temperature bath.....	6-34
Model TRIG-15/25 external trigger accessory.....	6-35
7: Troubleshooting.....	7-1
Using diagnostic spectra	7-3
Further assistance.....	7-8
8: Introduction to lifetime measurements	8-1
Introduction	8-1
Lifetime measurements	8-2
Types of lifetime scans	8-4
9: Xenon Lamp Information & Record of Use Form.....	9-1
Xenon lamp record of use	9-3
10: Applications.....	10-1
Introduction	10-1
Detecting sub-picomolar concentrations of fluorescein.....	10-3
Reduced-volume samples	10-3
Fluorescence detection of highly scattering samples.....	10-4
Quantum-yield calculations	10-4
Characterizing complex mixtures via synchronous scanning.....	10-4
Operating in the IR region	10-5
Phosphorescence for time-resolved data.....	10-5
Low-temperature scans	10-6
Monitoring kinetic reactions using time-based fluorescence.....	10-6
Front-face detection to enhance data collection for absorbent or solid samples	10-6
Polarization to detect trace quantities of biological probes	10-7
11: Producing Correction Factors	11-1
Introduction	11-1
Generating emission correction factors.....	11-2
Calculating emission correction factors.....	11-8
Calculating excitation correction factors.....	11-15
12: Determining the Plateau Voltage	12-1
Introduction	12-1
Overview of the procedure	12-1
Procedure	12-3
13: Reassembly Instructions.....	13-1
Computer	13-1
Spectrofluorometer assembly.....	13-2
Cable connections	13-3
Connecting power cables	13-7
14: Using TRIAX with the Fluorolog®-3.....	14-1
Introduction	14-1

Hardware	14-2
Software	14-4
Correcting data with the TRIAX	14-35
TRIAX 320 Specifications	14-38
Troubleshooting	14-39
15: Technical Specifications	15-1
Spectrofluorometer system	15-2
Minimum computer requirements	15-4
Software	15-4
16: Glossary	16-1
17: Bibliography	17-1
18: Index	18-1

0: Introduction

About the Fluorolog[®]-3

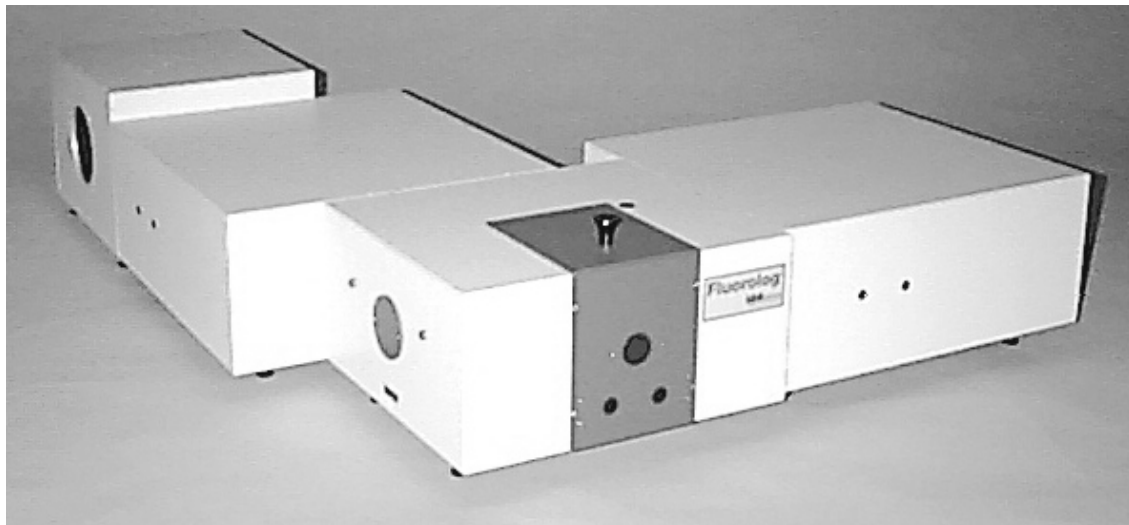

The main parts of the Fluorolog[®]-3 spectrofluorometer system are:

- State-of-the-art optical components
- A personal computer
- DataMax for Windows[™], the driving software.

This manual explains how to operate and maintain a Fluorolog[®]-3 spectrofluorometer. The manual also describes measurements and tests essential to obtain accurate data. For a complete discussion of the almost limitless power provided by DataMax, refer to the *DataMax Data Collection Handbook* (contains data-acquisition information) and the *Grams/32[®] User's Guide* (contains post-processing instructions for data manipulation) which accompany the system.

The combination of time-tested, performance-proven hardware with the powerful data-acquisition and manipulation software yields a system suitable for a wide variety of applications. Equipped with expansion ports and slots, the Fluorolog[®]-3 can grow to meet the changing needs of the user, it will provide years of dedicated service, and can be updated easily to the Fluorolog[®]-Tau-3.



Note: Keep this and the other reference manuals near the system.

Chapter overview

- | | |
|---|--|
| 1: Requirements & Installation | Power and environmental requirements; select the best spot for the instrument. |
| 2: System Description | Various Fluorolog [®] -3 configurations; their features and benefits. |
| 3: System Operation | Operation of the spectrofluorometer system, and calibration instructions. |
| 4: Optimizing Data Acquisition | Hints for improving the signal-to-noise ratio, instructions for obtaining corrected data, and other information useful for optimizing data and ensuring reproducibility. |
| 5: System Maintenance | Routine maintenance procedures such as replacing the lamp. |
| 6: Components & Accessories | Description and application of the accessories available for the Fluorolog [®] -3. |
| 7: Troubleshooting | Potential sources of problems, their most probable causes, and possible solutions. |
| 8: Introduction to Lifetime Measurements | Methods of determining the lifetime of a sample using the Fluorolog [®] -Tau-3. The Fluorolog [®] -Tau-3 is designed specifically for phosphorescence applications, and does not affect steady-state measurements. |
| 9: Xenon Lamp Information & Record of Use Form | Information about the xenon lamp, and a form for recording the xenon-lamp usage. |
| 10: Applications | Some interesting uses for the Fluorolog [®] -3. |
| 11: Producing Correction Factors | How to correct for variation in sensitivity across the spectral range. |
| 12: Determining the Plateau Voltage | Finding the optimum voltage for the detector. |
| 13: Reassembly Instructions | How to reassemble the Fluorolog [®] -3 after it has been moved. |

14: Using TRIAX with the Fluorolog®-3

Special instructions on using a TRIAX imaging spectrometer with the Fluorolog®-3 system, including with a CCD detector.

15: Technical Specifications

Instrument specifications and computer requirements.

16: Glossary

A list of some useful technical terms related to fluorescence spectroscopy.

17: Bibliography

Important sources of information.

18: Index

Symbols used in this manual

Certain symbols are used throughout the text for special conditions when operating the instruments:



A hazardous condition exists, or danger exists that could damage the equipment. Jobin Yvon Inc. is not responsible for damage arising out of improper use of the equipment.

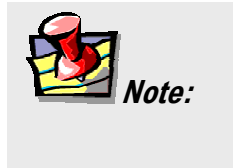

General information is given concerning operation of the equipment.

1: Requirements & Installation

Surface requirements

- A sturdy table- or bench-top.
- Table size varies according to the system configuration; an average size of 38" × 60" (96.5 cm × 152.4 cm) is usually sufficient.



Warning: Do not split the system between two tables. Using two tables can cause instability, resulting in service requirements or erroneous data.

Table size for standard systems*

	FL3-11	FL3-12	FL3-21	FL3-22
Length	144 cm	156 cm	173 cm	173 cm
Width	37 cm	53 cm	66 cm	66 cm
Height	43 cm	43 cm	43 cm	43 cm

*Custom configurations are available. See the *System Description* chapter.

Environmental requirements

- Temperature $72 \pm 5^\circ\text{F}$ ($22 \pm 3^\circ\text{C}$)
- Humidity level $\sim 70\%$
- No special ventilation.



Note: The standard xenon lamp provided with the Fluorolog[®]-3 is ozone-free. The lamp housing contains an electrically powered fan that removes the heat.

Electrical requirements

- 115 V, 20 A or 220 V, 20 A; factory-set.
- As an extra measure of caution, plug the xenon lamp into a circuit separate from the other components. This guarantees that the electrical surge from the lamp never will interfere with the computer or system.



Note: For the computer, Jobin Yvon Inc. recommends using a surge suppressor or an uninterruptible power supply (UPS) with a surge suppressor.

Make sure enough AC outlets are available for the

- Computer
- Printer (optional)
- Monitor
- Xenon lamp
- System controller (SAC)

Use three-prong plugs for proper grounding of the system. If a two-prong adapter is used, for the safety of the operator and to preserve the integrity of the system, the adapter must be attached to the wall outlet properly, according to the manufacturer's instructions. This provides a positive connection to the electrical ground (earth), ensuring that any stray or leakage current is directed to earth ground.



Warning: A three-prong-to-two-prong adapter *is not recommended.*

Installation



Warning: *Customer installation is not recommended. Special tools and several critical alignment verification procedures are required.*

Schedule the initial installation of a Fluorolog[®]-3 by calling the Spex[®] Fluorescence Service Department at (732) 494-8660 × 160. Customers outside the United States should contact a local representative. For up-to-the-minute information about products, services, upgrades, frequently-asked questions, etc., visit our web site:

<http://www.jyhoriba.com/fluor/fluor.htm>

Subsequent assembly because of relocation either can be performed by a Jobin Yvon Inc. engineer for a specified fee, or by the user. Re-assembly instructions and diagrams are provided in Chapter 13: *Reassembly Instructions*.

2: System Description

Overview

General operation

All Fluorolog[®]-3 spectrofluorometers have common features:

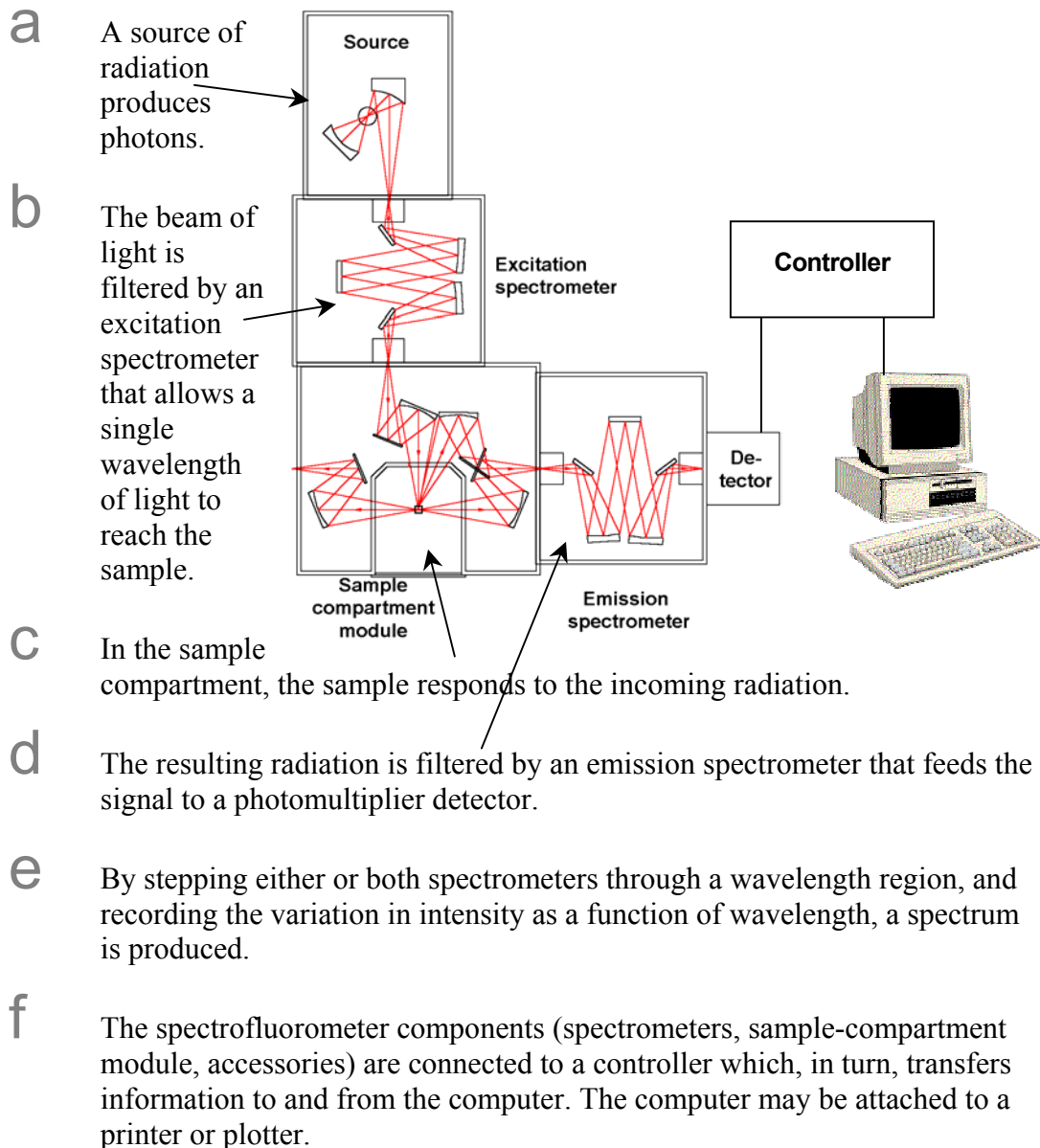

Basic components

Spectrometers

The Fluorolog[®]-3 comes equipped with either a single- or double-grating spectrometer in the excitation and emission positions. Double-grating spectrometers offer a significant increase in sensitivity, resolution and stray-light rejection.

Sample compartment

The standard sample-compartment module is a *T-box*, which provides efficient throughput with a choice of standard right-angle emission collection or optional front-face emission collection. The sample-compartment module comes equipped with a silicon photodiode reference detector to monitor and compensate for variations in the xenon lamp output.

Accessories

Fluorolog[®]-3 spectrofluorometers offer sampling accessories to increase flexibility, and extend their applications to techniques such as polarization measurements or phosphorescence lifetimes.

Configurations

The different configurations and various accessories available for the Fluorolog[®]-3 system allow you to customize a system specific for today's needs, while the interchangeability of the components and the inherent design enable the system to grow and change as new applications arise.

Standard systems

The standard Fluorolog[®]-3 systems include a single- or double-grating monochromator in the excitation and emission paths in an "L" configuration.

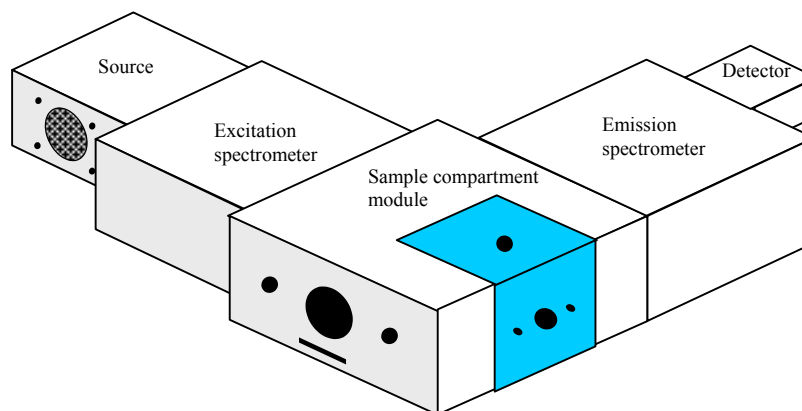

Standard systems available:

Model	Source	Excitation Spectrometer	Sample Compartment Module	Emission Spectrometer	Detector
FL3-11	450-W Xe	Single	T-Box	Single	PMT
FL3-12	450-W Xe	Single	T-Box	Double	PMT
FL3-21	450-W Xe	Double	T-Box	Single	PMT
FL3-22	450-W Xe	Double	T-Box	Double	PMT

Fluorolog[®]-3 Model FL3-11

The Fluorolog[®]-3 Model FL3-11 is an economical system designed for routine fluorescence measurements.

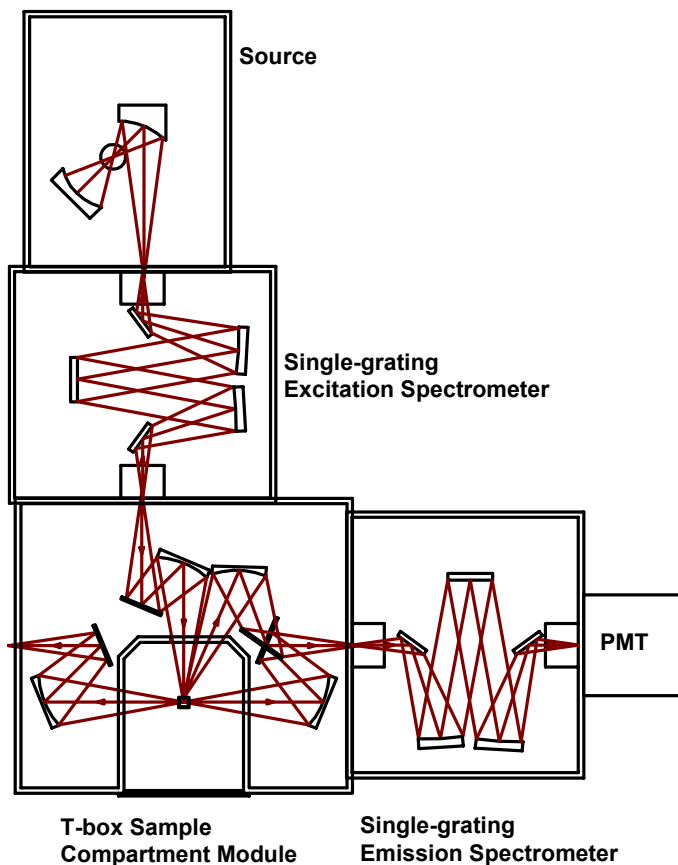

The standard model FL3-11 comes equipped with:

- 450-W light source
- single-grating excitation spectrometer
- single-grating emission spectrometer
- automatic slits
- room-temperature R928P detector

Fluorolog[®]-3 Model FL3-12

The Fluorolog[®]-3 model FL3-12 provides optimum performance for highly scattering samples such as proteins, membranes, and solid samples.

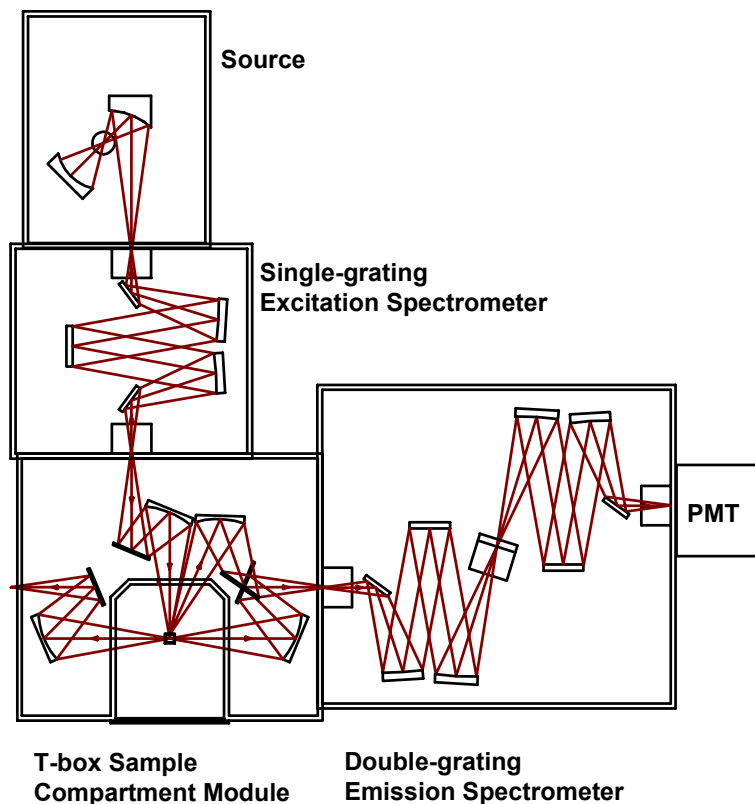

Like the Model FL3-11, the Fluorolog[®]-3 Model FL3-12 has a single-grating excitation spectrometer; but the optimum performance of the Model FL3-12 is as a result of a double-grating emission spectrometer. Features of the Model FL3-12 are:

- 450-W light source
- single-grating excitation spectrometer
- double-grating emission spectrometer
- automatic slits
- room-temperature R928P detector

Fluorolog[®]-3 Model FL3-21

The Fluorolog[®]-3 model FL3-21 includes a double-grating spectrometer at the excitation position.

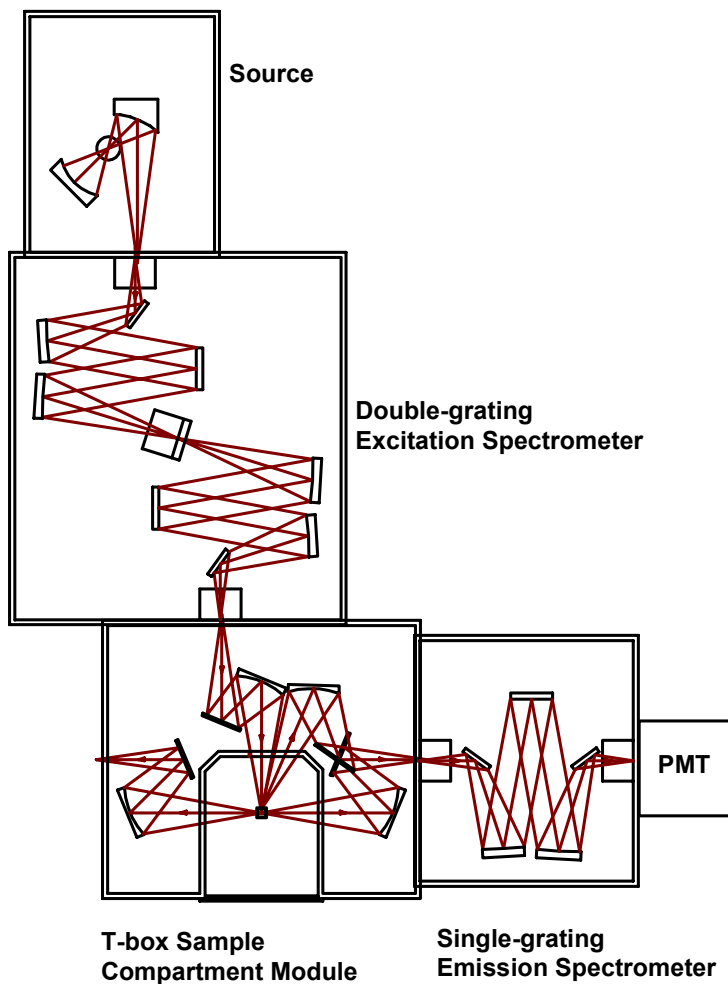

Features of the Model FL3-21 are:

- 450-W light source
- double-grating excitation spectrometer
- single-grating emission spectrometer
- automatic slits
- room-temperature R928P detector

Fluorolog[®]-3 Model FL3-22

Because of the double-grating excitation and emission spectrometers, the Fluorolog[®]-3 model FL3-22 offers unsurpassed performance in resolution, sensitivity, and stray-light rejection. This system is perfect for highly scattering samples like lipids and proteins, or solids like powders, semiconductors, or phosphors.

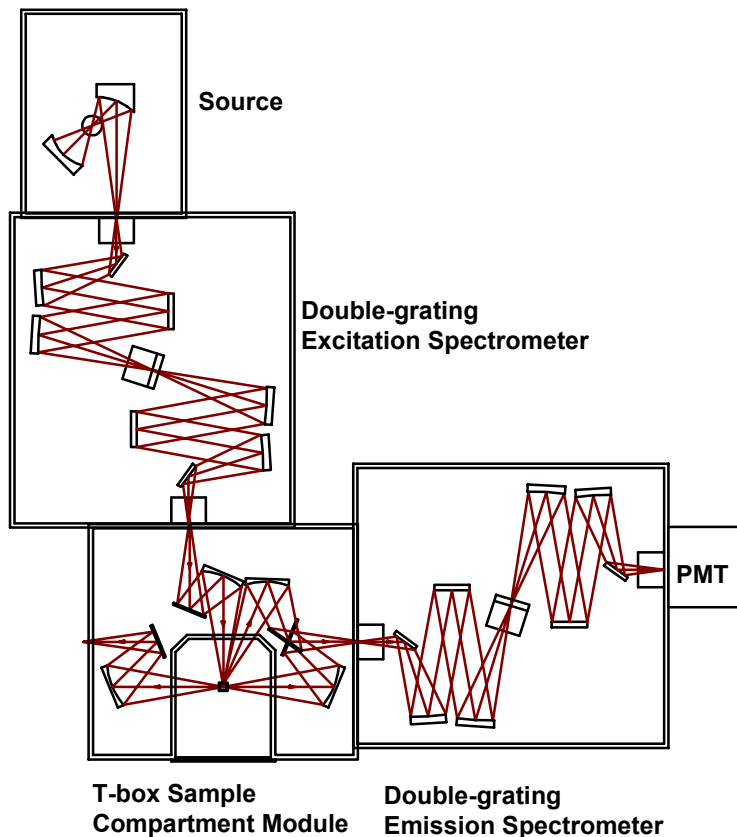

Incorporating double-grating spectrometers in both the excitation and emission positions places this model in a category by itself. Enhanced features, modular structure, and few external controls are just a few of the reasons to consider a Fluorolog[®]-3 model FL3-22:

- 450-W light source
- double-grating excitation spectrometer
- double-grating emission spectrometer
- automatic slits
- room-temperature R928P detector

Standard options

The previously described systems represent the standard configurations. Each system, however, can be customized by selecting different components. Available options are listed below. For additional information, or for a list of the most recently developed products, contact a Spex[®] Fluorescence Sales Representative.

Sources

- Pulsed lamp
- HgXe
- Your laser

Detectors

- Cooled PMT
- IR
- CCD

Refer to Chapter 6, *Components and Accessories*, for a list of accessories that will help you further tailor a system to your application needs.

Custom configurations

With custom configurations, you can change the layout of the system to a T-format or add the high-performance TRIAX 320M imaging spectrograph at the emission port of the system. Using single-grating, double-grating, or the TRIAX 320M imaging spectrometer, you can create a system for almost any application. Details on using a TRIAX are given in Chapter 14: *TRIAX Operation with the Fluorolog[®]-3*. Some of the more popular configurations are described on the following pages.

Fluorolog®-3 Model FL3-XXX

Systems with the T-configuration design were developed for T-format polarization or anisotropy and dual-emission spectroscopy. Models FL3-XXX (where the Xs are the type of spectrometer positioned at the excitation, first-emission, and second-emission positions, respectively) are available in numerous configurations.

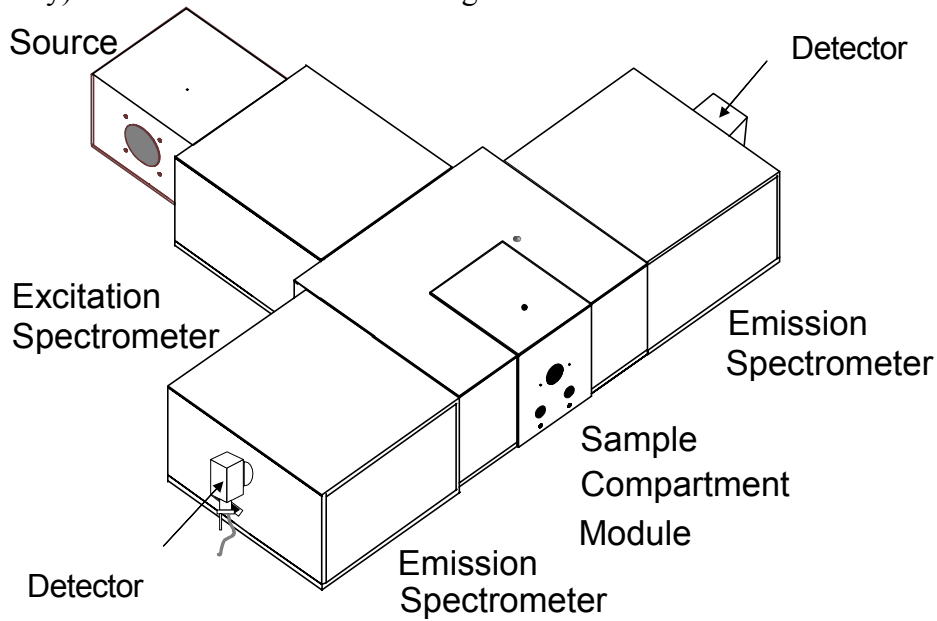

Fluorolog®-3 model FL3-122

The T-configuration allows the Xe source and the signal detector to be positioned at right-angles to the sample, for a variety of experiments with results unequaled by other configurations. The optical configuration of the model FL3-122 is shown below.

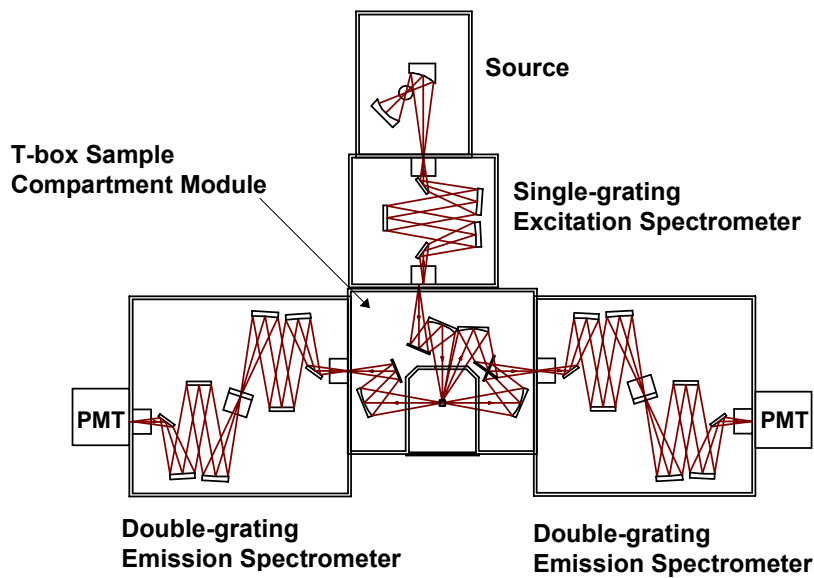

Optical layout of the Fluorolog®-3 Model FL3-122.

Fluorolog[®]-3 Model FL3-12-320M

The fully automated TRIAX 320M imaging spectrometer can be a part of a custom Fluorolog[®]-3 configuration. The imaging spectrograph offers the latest advances in optical design and automation.

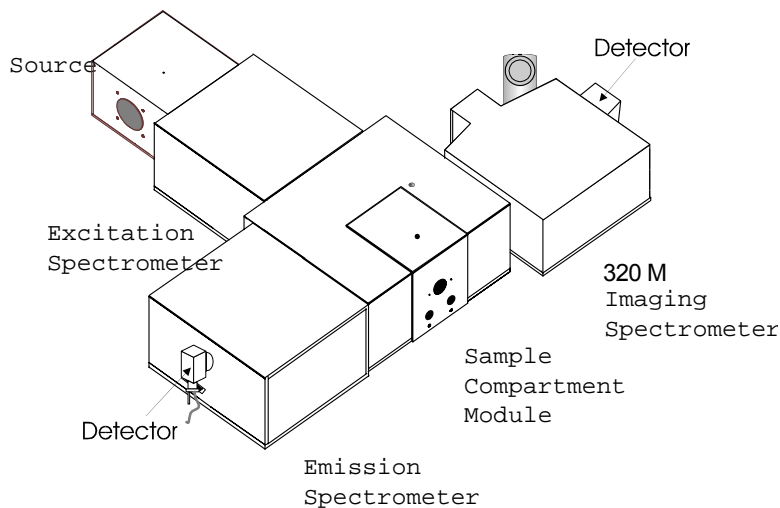

Fluorolog[®]-3 with a double-grating emission spectrometer and a TRIAX 320M imaging spectrometer

The optical configuration of this system is shown below.

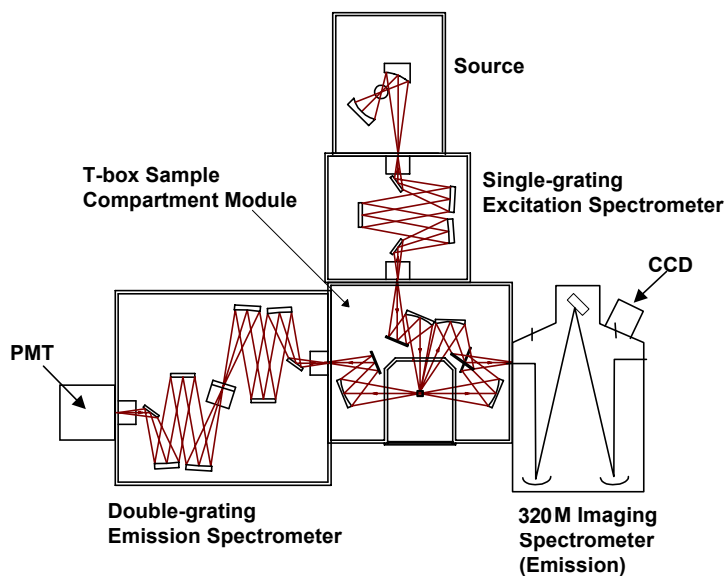

Custom optical layout. By switching the TRIAX 320M and double-grating spectrometer, both right-angle and front-face collection are possible.

The unique optical layout of the TRIAX 320M eliminates rediffracted light. In addition, with the single-grating excitation spectrometer in place, the TRIAX 320M imaging spectrograph can be placed on either side of the sample-compartment module. When the TRIAX 320M imaging spectrometer is used as the first emission spectrometer (not pictured), both front-face and right-angle collection are possible.

Custom options

Each system can be customized further by selecting different options. Available options are listed below. For additional information, or for a list of the newest options, contact a Spex[®] Fluorescence Product Specialist.

Sources

- Pulsed lamp
- HgXe
- Your laser

Detectors

- Cooled PMT
- IR
- CCD

Refer to Chapter 6, *Components and Accessories*, to see accessories that will help you further tailor a system to your needs.

3: System Operation

Turning on the system

1 Start the lamp.

The lamp must be turned on prior to the Fluorolog[®]-3, accessories, and peripheral equipment.

- a On the back of the lamp housing, turn on the switch marked "power."



- b Just above the "power" switch, turn on the "main lamp" switch.

2 Start the fluorometer accessories.

Turn on any automated accessories (e.g., Temperature Bath, MicroMax, etc.) used with the Fluorolog[®]-3.

3 Start the SpectrAcq.

- a Make sure the boot disk is in the floppy drive.
- b Push in the power button to start. Immediately below the power button, the green LED indicator lamp should turn on.



Note: The boot disk should access for ~ 60 s to load system drivers.



Warning: When the lamp is turned on, a large voltage is put across the lamp, during which a spike can feed back down the electrical line. This spike can cause damage to computer equipment if the equipment is operating at the time and on the same power circuit as the Fluorolog[®]-3, when the lamp is started.

4 Start the peripheral devices.

Turn on all peripheral devices such as printers and plotter (i.e., all devices other than the computer).

5 Start the computer and software.

a Turn on the computer.

b In Windows™, click on the DataMax icon to start **Instrument Control Center**. The **Layout Selection** window appears.

c In the **Layout Selection** window, select the layout to use.

The Fluorolog®-3 spends ~ 1 min initializing, then the **Instrument Control Center** appears:



Note: The layout filename will vary, depending on the instrument configuration.

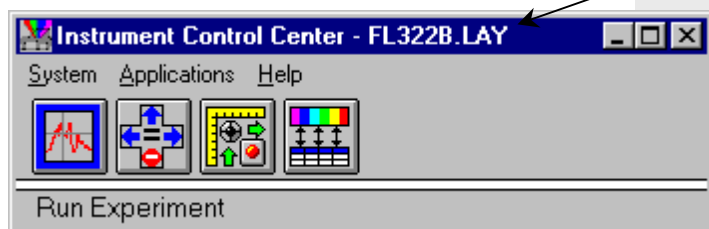

d Choose one of the four available applications:

Run Experiment



Real Time Display



Visual Instrument Setup



Constant Wavelength Analysis



If there are difficulties in starting the software or initializing the Fluorolog®-3, please refer to Chapter 7: *Troubleshooting* for suggestions.

Checking system performance

Introduction

Upon installation and as part of routine maintenance checks, examine the performance of the Fluorolog[®]-3. Jobin Yvon Inc. recommends checking the system calibration before each day of use with the system. Scans of the xenon-lamp output and the Raman-scatter band of water are sufficient to verify system *calibration*, *repeatability*, and *throughput*.

- *Calibration* is the procedure whereby the drive of each spectrometer is reference to a known spectral feature.
- *Repeatability* is the ability of the system to produce consistent spectra.
- *Throughput* is the amount of signal passing through and detected by the system. The throughput is correlated to the signal-to-noise ratio and sensitivity of the system.

The Fluorolog[®]-3 is an *autocalibrating* spectrofluorometer. This means the system initializes its monochromator's drives, locates the home position of the each drive, and assigns a wavelength value to this position from a calibration file. While the system usually maintains calibration by this method, it is wise to check the calibration prior to the day's session with the instrument. For the calibration checks detailed here, a single-sample mount or automated sample changer should be the only sample-compartment accessories used.

The scans shown herein are *examples*. A Performance Test Report for your new instrument is included with the documentation. Use the Performance Test Report to validate the spectral shape and relative intensity taken during the calibration checks.

These scans are described for systems with the default 1200-grooves/mm gratings and an R928P PMT emission detector with coverage from the UV to high visible. If the monochromators contain gratings with groove densities other than 1200 grooves/mm, with different wavelength sensitivity, or with a different emission detector, please consult the Performance Test Report for appropriate scan parameters.

Excitation calibration check

This calibration check verifies the wavelength calibration of your excitation monochromator, using the reference photodiode located before the sample compartment. It is an excitation scan of the xenon lamp's output, and should be the first check performed.

- 1 Secure the lid of the sample chamber in place.
- 2 On the **Run Experiment** toolbar, select the Experiment button.



This opens the **Emission Acquisition** dialog box:

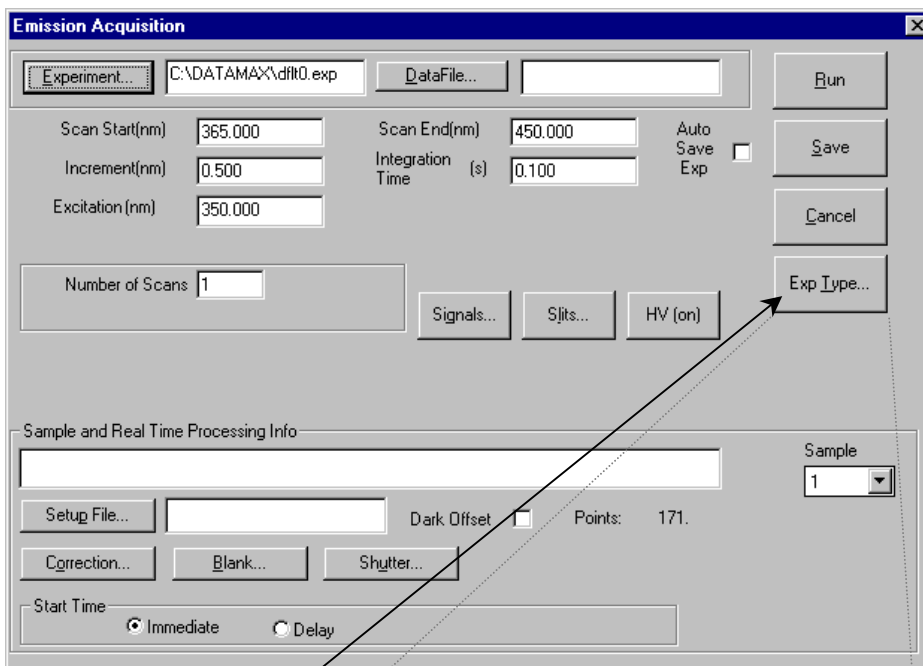

- 3 Click on the Exp Type... button.
This opens the **Select Experiment Type** dialog box:

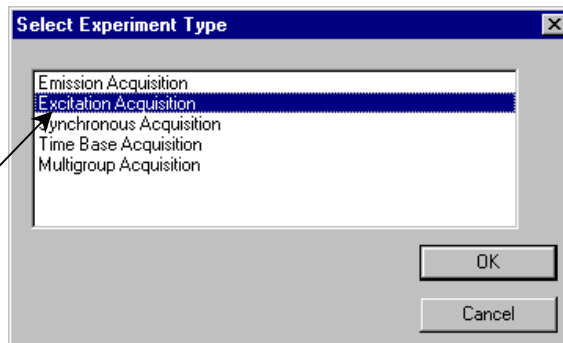

- 4 Choose Excitation Acquisition.

Click OK to close the **Select Experiment Type** dialog box. The **Emission Acquisition** window

converts to **Excitation Acquisition**. (For calibration and calibration verification, always adjust the excitation spectrometer first.)

5 Set the scan parameters for the xenon lamp scan:

a In the **Excitation Acquisition** dialog box:

Name the experimental parameters `lamp.exp`,
Start the scan at 220 nm,
Step the wavelength by 0.5 nm,
Set the emission to 650 nm,
Perform 1 scan.

Use a filename `lamp.spc`,
End the scan at 600 nm,
Use an Integration Time of 0.1 s.

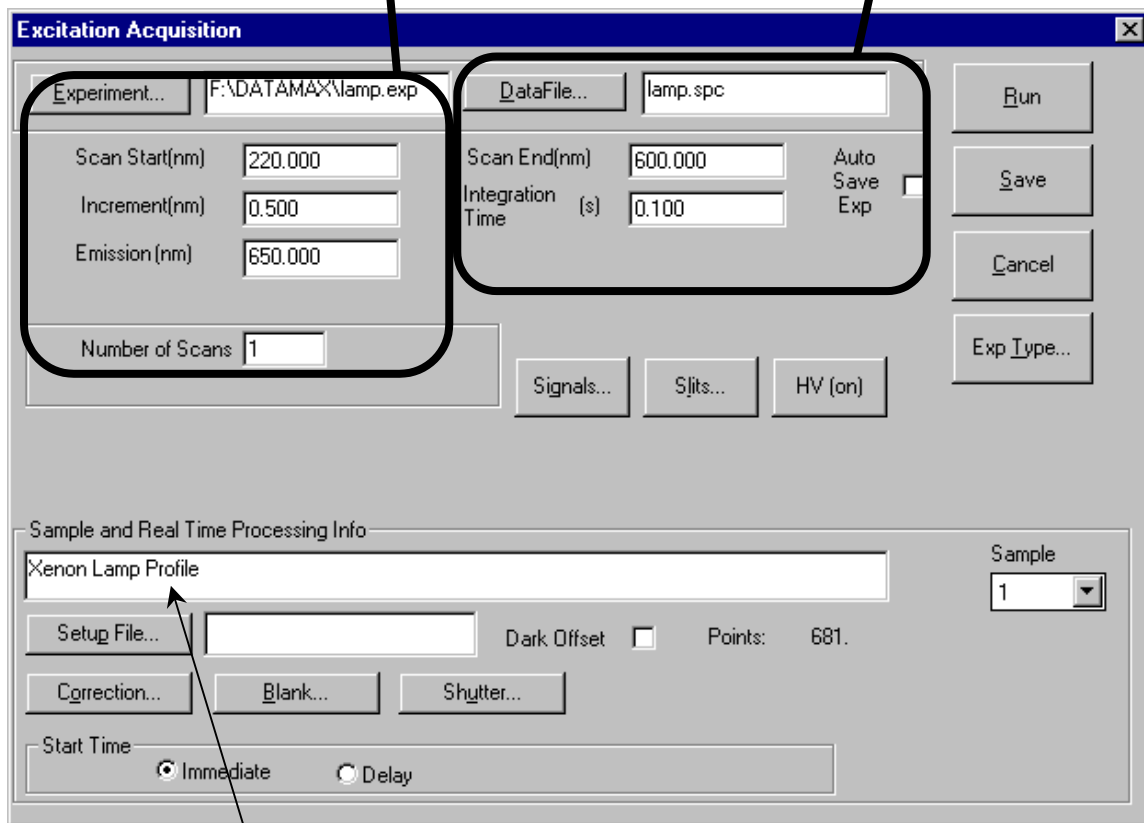

Describe the file as the spectral profile of the xenon lamp.

- b** Click on Signals...
 This opens the **Signals** dialog box.
 Enter R (reference), then click OK to close the box.

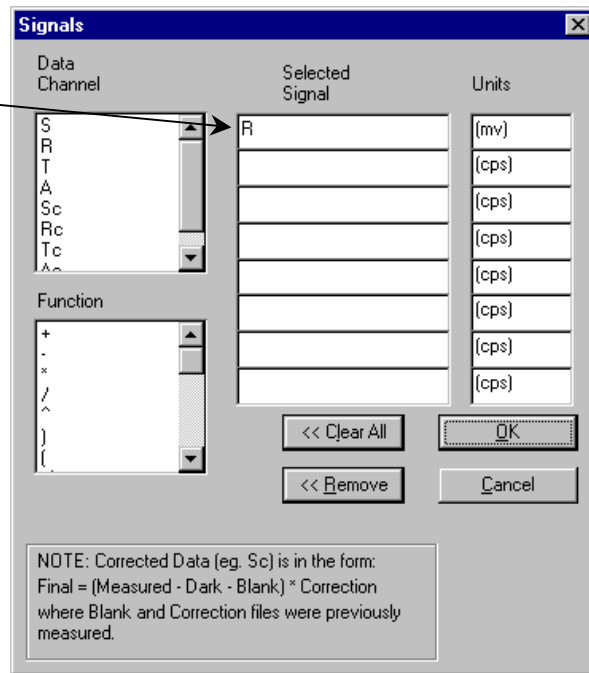

- c** Click on Slits...
 This opens the **Slits** dialog box.
 Set the excitation entrance and exit slits to 0.5 mm.
 Set the emission entrance and exit slits to 0 mm (closed).
 Click OK to close the window.

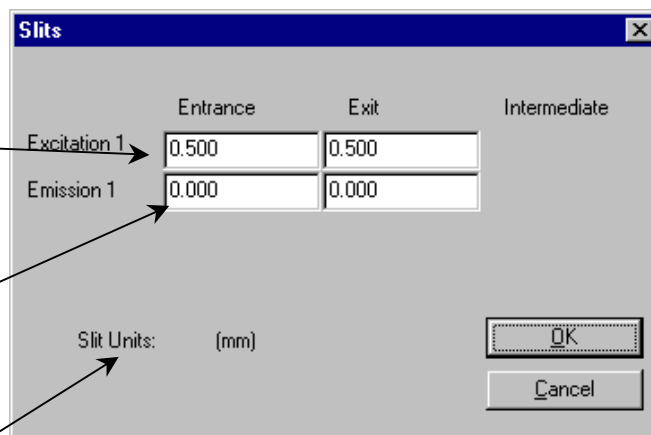

If the slits' units are not in millimeters (mm), then open **Visual Instrument Setup**, select **Options**, then **Units**, and set the slits' units to mm. Use the reference (R) detector channel.

- d** Click Run to execute the scan.

Lamp scan for single-monochromator systems:

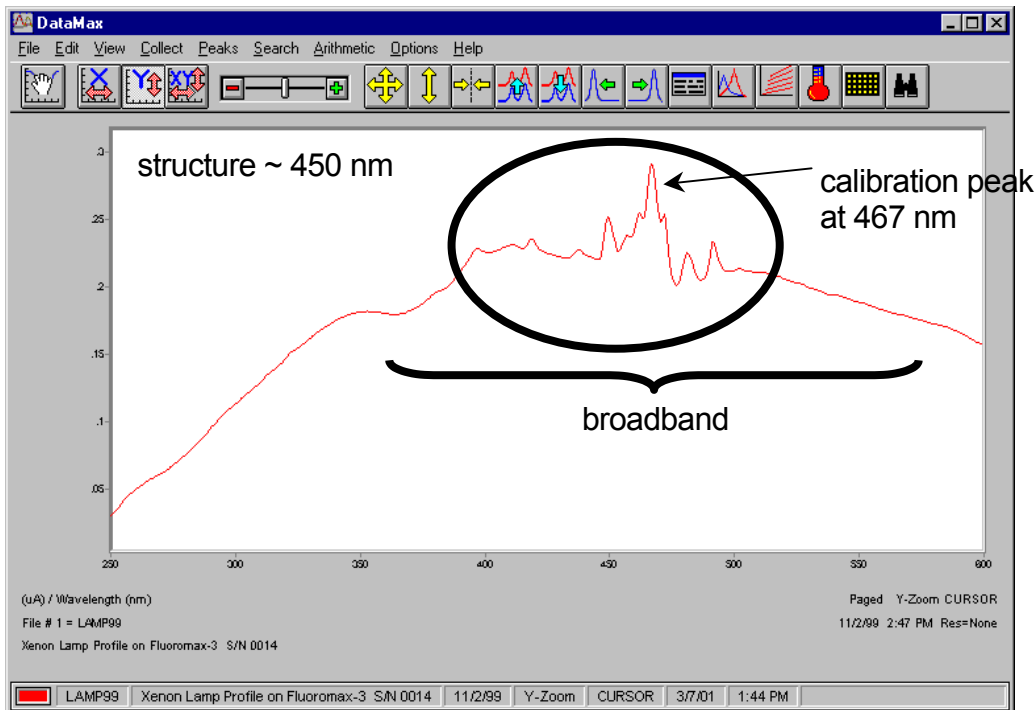

Xenon-lamp scan for an FL3-11 spectrofluorometer.

Lamp scan for double-monochromator systems:

On a double-monochromator system, the 467-nm line is no longer the most intense peak within the spectrum. Take care to isolate the 467-nm calibration line from other peaks.

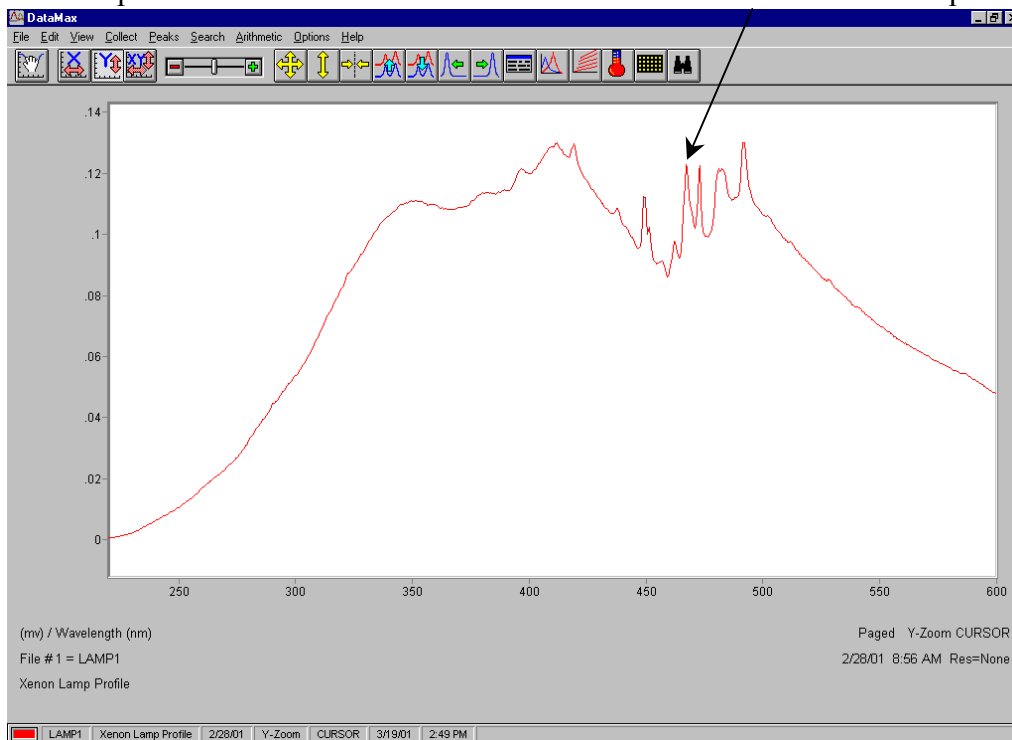

Xenon-lamp scan for a double-monochromator spectrofluorometer.

6 Find the calibration peak for the xenon-lamp spectrum.

The 467-nm peak is used for excitation calibration. The intensity of this spectrum should be noted for reference, although it is not used for instrument specifications.

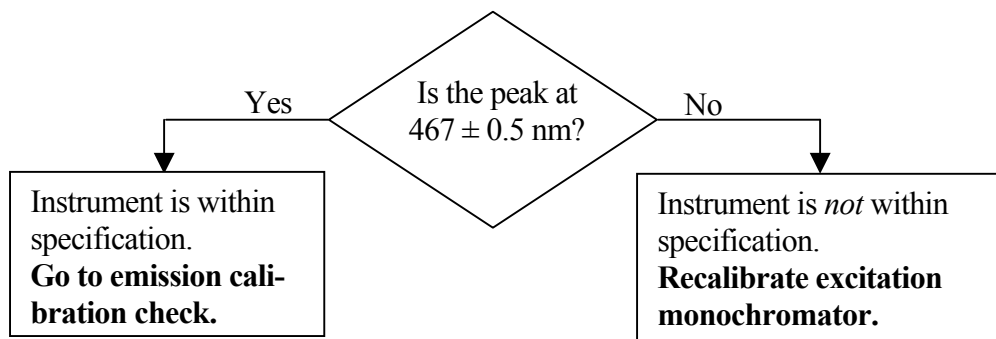

Excitation monochromator recalibration

Re-calibration of the Fluorolog[®]-3 is performed by moving to the position of the observed peak, going into **Visual Instrument Setup**, and telling the software the correct position at which this peak should be. The software will save this change in position to the calibration file.

- 1 Note the wavelength where the 467-nm peak was observed.
- 2 Open the **Real Time Display**.
- 3 Set the excitation monochromator to the position where the peak was observed.
Hit the Tab key on the keyboard to set the monochromator to the entered value.
- 4 Close the **Real Time Display**.

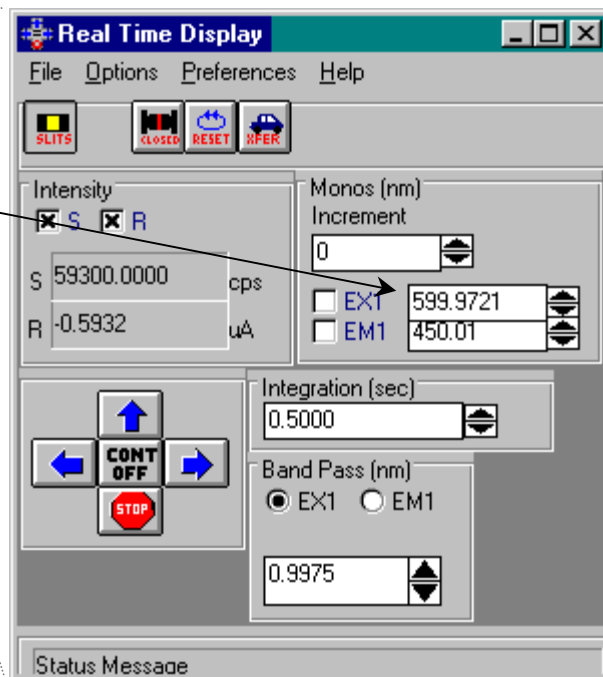

5 Open the **Visual Instrument Setup** dialog box:

 **Note:** The *Visual Instrument Setup* will vary, depending on the instrument configuration.

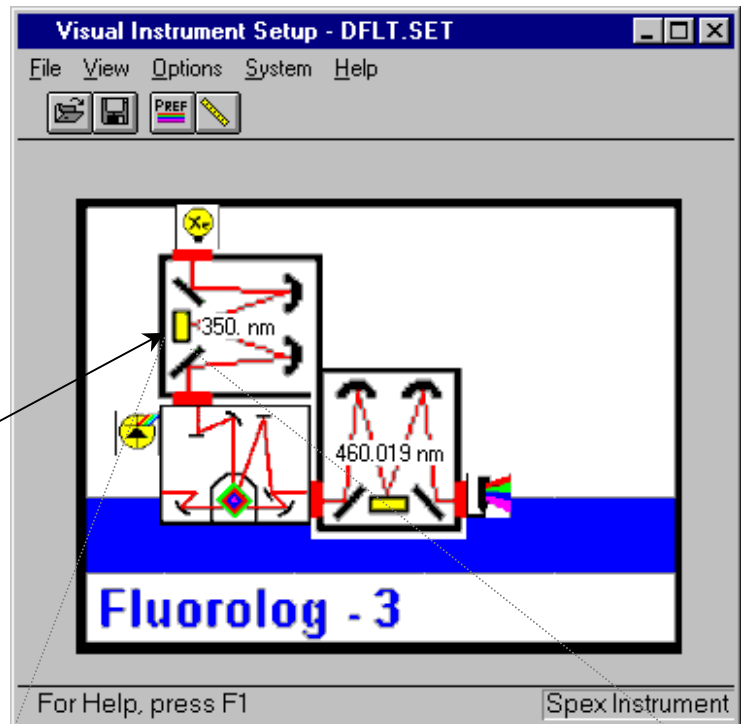

6 Click on the grating for the excitation monochromator.

The **Grating/Turret** dialog box appears.

7 Click on the **Calibrate...** button.

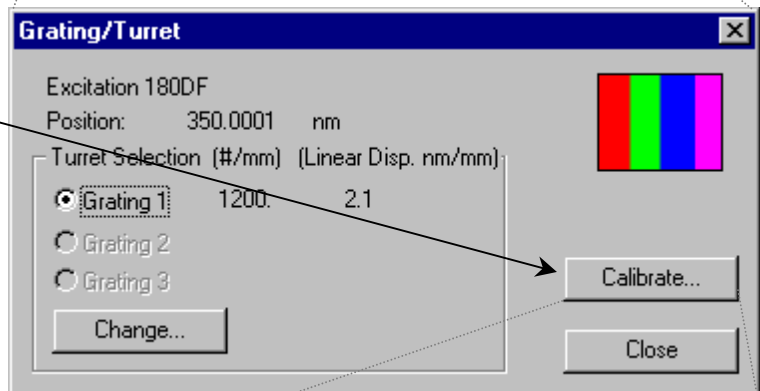

This opens the **Enter Correct Position** dialog box:

8 Enter the actual xenon-lamp peak, 467 nm.

9 Click **OK**.

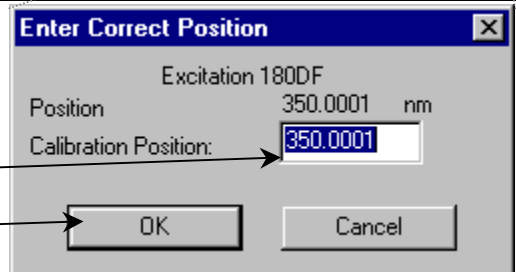

The excitation monochromator should now be calibrated.

10 Click **Close** to close the **Grating/Turret** dialog box.

11 Close **Visual Instrument Setup**.

12 Confirm that the excitation monochromator is calibrated by running another lamp scan in **Run Experiment**.

This time the peak should occur at 467 ± 0.5 nm.

Emission calibration check



Note: The emission calibration of the instrument is directly affected by the calibration of the excitation monochromator.

This calibration check verifies the wavelength calibration of the emission monochromator with the emission photomultiplier tube. It is an emission scan of the Raman-scatter band of water performed in right-angle mode. This check should be performed after the xenon-lamp scan. When completed, the performance of the system has been verified.

The water sample should be research-quality, triple-distilled or de-ionized water. HPLC-grade (18-MΩ spec.) or equivalent water is suggested for the Raman scan. Impure samples of water will cause elevated background levels as well as distorted spectra with (perhaps) some unwelcome peaks.

Use a 4-mL quartz cuvette.



Note: Avoid glass or acrylic cuvettes: they may exhibit UV fluorescence or filtering effects.

- 1 **Insert the water sample into the sample compartment.**

With an automated sample changer, note the position number in which the sample cell is placed.

- 2 **Make sure the lid of the sample chamber is securely in place.**
- 3 **In the **Run Experiment** toolbar, choose the **Experiment** button.**

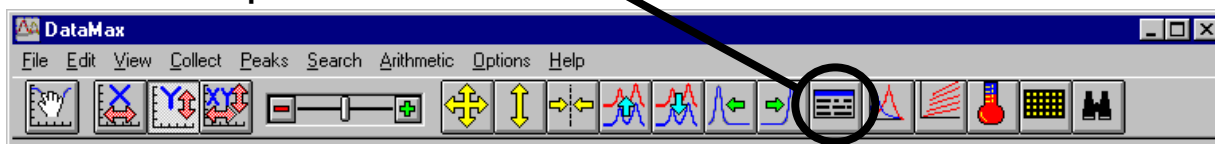

This opens the **Emission Acquisition** dialog box.

- a Click on Exp Type... to open the **Select Experiment Type** dialog box:

Choose **Emission Acquisition**. Click OK to close the box.

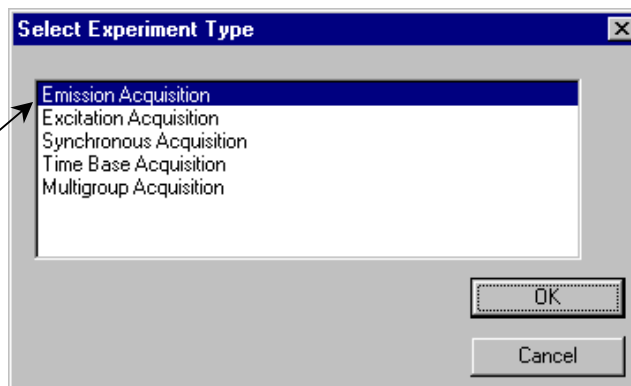

b In the **Emission Acquisition** dialog box:

Name the experimental setup `water.exp`,
 Start the scan at 365 nm,
 Step the wavelength by 0.5 nm,
 Set the excitation to 350 nm,
 Perform 1 scan.

Use a filename `water.spc`,
 End the scan at 450 nm,
 Use an Integration Time of 0.5 s.

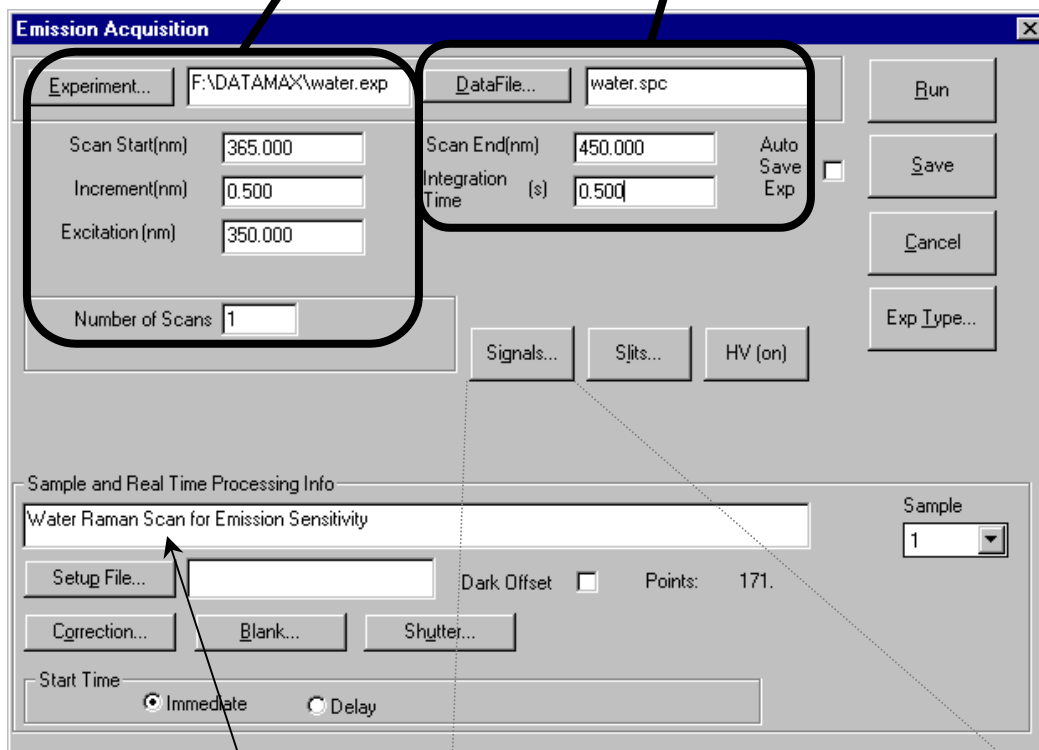

Describe the file as a water Raman-emission spectrum.

c Click on the **Signals...** button to open the **Signals** dialog box:

Set the signal (S) detector.
 Click OK to close the box.

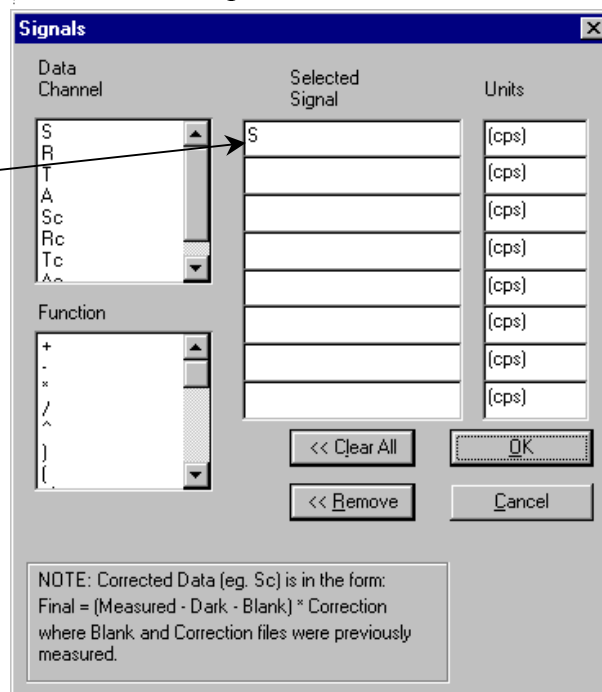

d Click on the **Slits...** button to open the **Slits** dialog box:

Set the slits to 5 nm. Click **OK** to close the box.

If your slits' units are not in bandpass units (nm), then open **Visual**

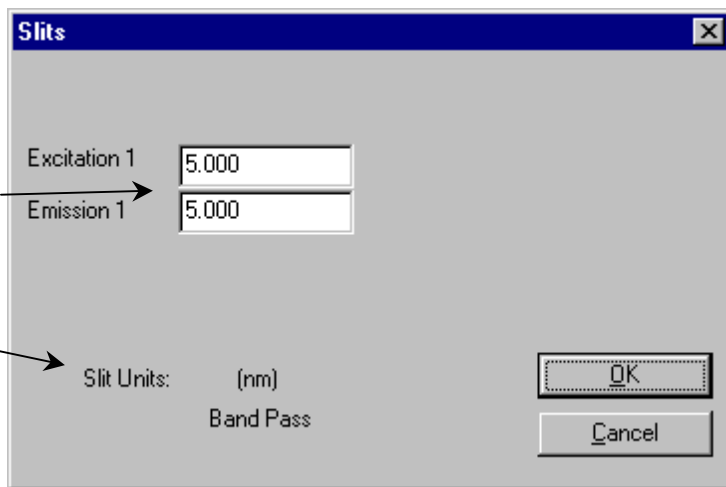

Instrument Setup, select **Options**, then **Units**, and set the slits' units to nm. If you have a Front-Face/Right-Angle accessory, set it to the RA position.

e Click **Run** to execute the scan.

Your spectrum should resemble the following:

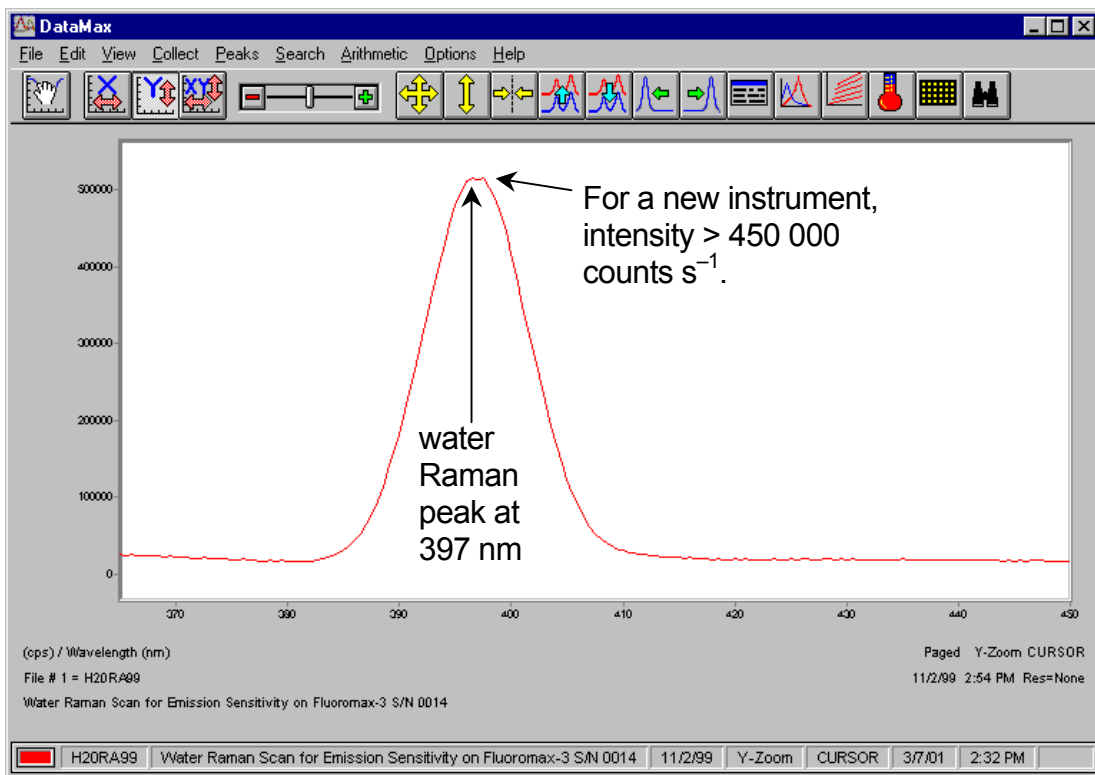

The Rayleigh scatter band or excitation band, which is about 10 times the intensity of the Raman band, occurs at 350 nm (the excitation wavelength). The scan begins at 365 in order to avoid detecting the Rayleigh band.



Note: Observed throughput (and hence peak intensity) is affected by lamp age and alignment, slit settings, and sample purity. As the xenon lamp ages, the throughput of the system will decline slowly. Therefore, low water Raman peak intensity may indicate a need to replace the xenon lamp.

4 Find the peak of the water Raman band.

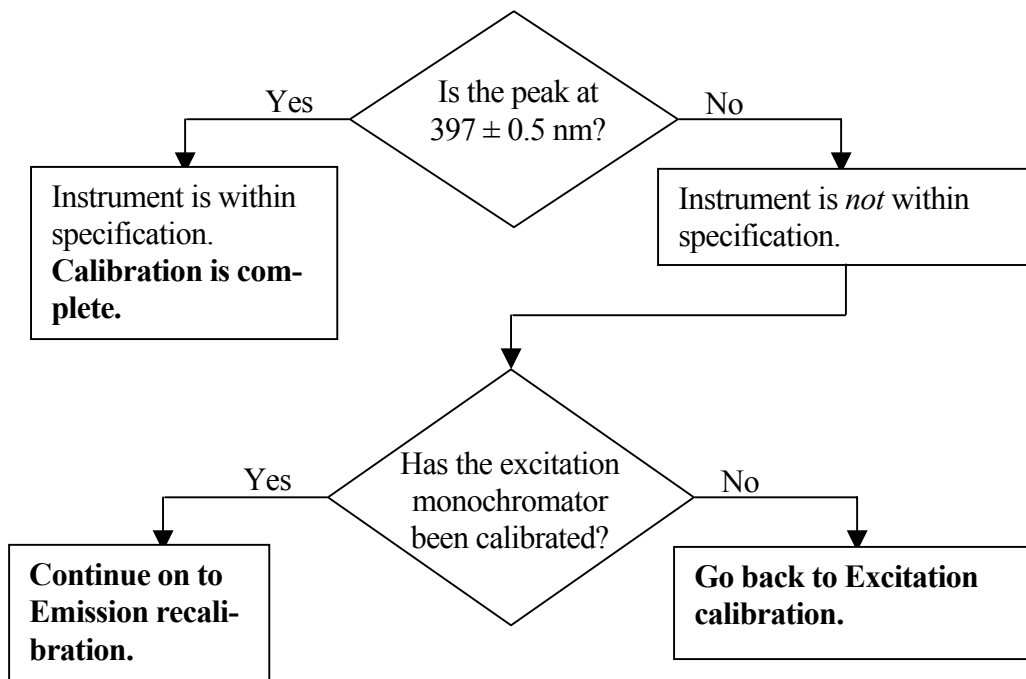

Emission recalibration

Calibration for the Fluorolog[®]-3 is performed by:

- Moving to the position of the observed peak,
- Going to the **Visual Instrument Setup** application, and
- Telling the software the correct position for this peak.

The software will save this change in position to the calibration file.

- 1 Note where the 397-nm peak was observed.
- 2 Open the **Real Time Display**.
- 3 Reset the emission monochromator to the position where the peak was observed.

Hit Tab on the keyboard to set the monochromator to the entered value.

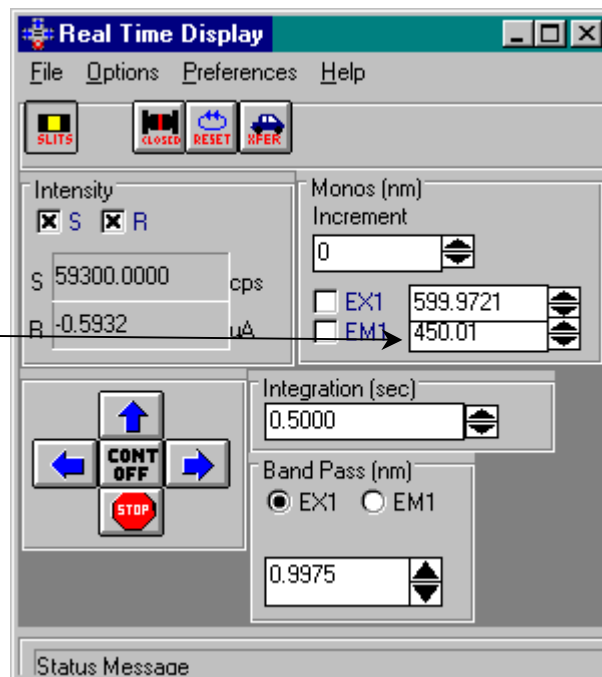

- 4 Close the **Real Time Display**.

5 Open the **Visual Instrument Setup** dialog box:

 **Note:** The *Visual Instrument Setup* will vary, depending on the instrument configuration.

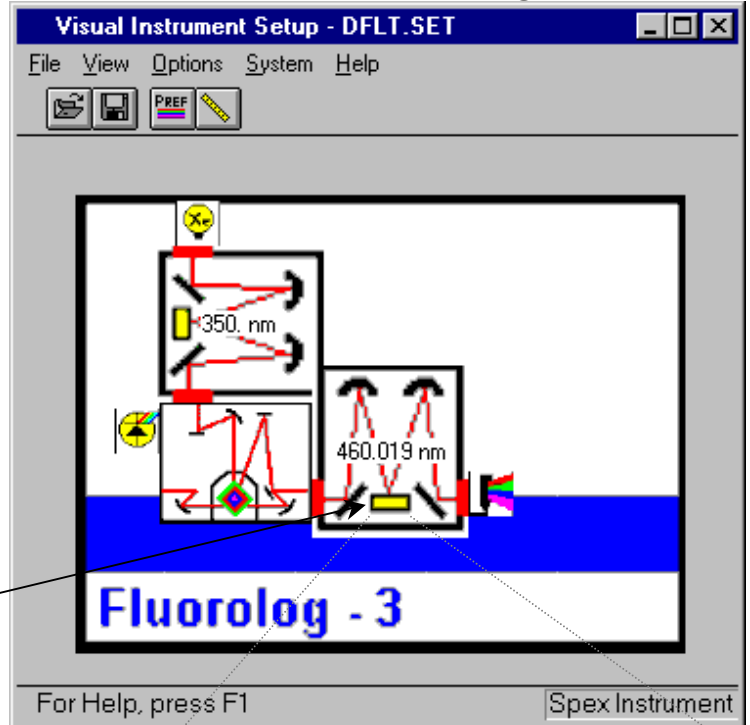

6 Click on the grating for the emission monochromator.

The **Grating/Turret** dialog box appears:

7 Click on the **Calibrate...** button.

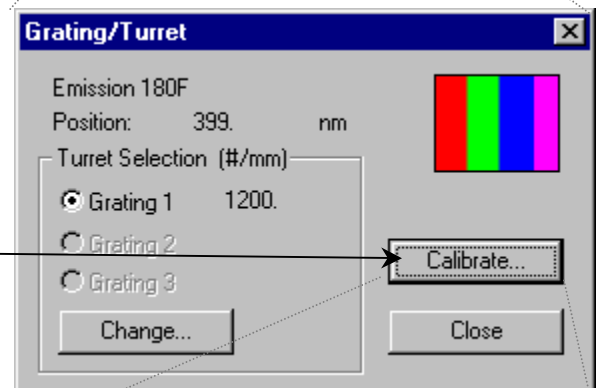

This opens the **Enter Correct Position** dialog box:

8 Enter 397 nm, the actual peak position using 350-nm excitation.

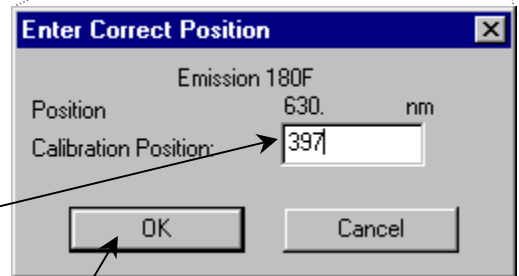

9 Click OK to close the dialog box.

The emission monochromator now should be calibrated.

10 Click OK to close the **Grating/Turret** dialog box.

- 11 Close **Visual Instrument Setup**.
- 12 Confirm that the emission monochromator is calibrated, by running another water Raman scan in **Run Experiment**.

This time the peak should occur at 397 ± 0.5 nm.

Notes on excitation and emission calibration

- Two experiments, `lamp.exp` and `water.exp`, have been defined and saved. They can be run, after the system is switched on each day, to check the calibration and performance of the Fluorolog[®]-3.
- Jobin Yvon Inc. recommends that the number of hours of xenon-lamp use be recorded in a log (see sample sheet in Chapter 9: *Xenon Lamp Information & Record of Use Form*).
- Additionally, you may want to record the water-Raman intensity daily or weekly.
- The lamp is rated for 1800–2000 h, but if the Raman intensity starts to drop, you may wish to change the lamp sooner.

Useful materials for characterizing system and samples

The following are materials that Jobin Yvon Inc. has found useful in determining system sensitivity or as standards for lifetime measurements.

Substance	CAS Number	Purpose	Emission Wavelength Range (nm)	Lifetime (ns)
Anthracene (99+%, zone-refined)	120-12-7	Excitation and emission spectral characterization	380–480	4.1 (in MeOH)
9-CA (97%), or 9-Anthracenecarbonitrile	1210-12-4	Single-exponential lifetime standard	380–500	11.8 (in MeOH)
Europium(III) chloride hexahydrate (99.9%)	13759-92-7	Phosphorescence emission and decay standard	580–700	1.40×10^5
Fluorescein (99%)	2321-07-5	Lifetime and sensitivity standard	490–630	4.02 (in pH \geq 11)
D-glycogen	9005-79-2	Light-scattering standard		0
LDS 750, or Styryl 7	114720-33-1	Single-exponential lifetime standard	680–700	0.248 (in MeOH, $\lambda_{\text{exc}} = 568$ nm)
LUDOX®, or colloidal silica	7631-86-9	Light-scattering standard		0
(Me) ₂ POPOP, or 1,4-bis-2-(4-methyl-5-phenyloxazolyl)-benzene	3073-87-8	Single-exponential lifetime standard	390–560	1.45 (in EtOH)
β -NADH (β -nicotinamide adenine dinucleotide)	606-68-8 or 104809-32-7	Single-exponential lifetime standard	390–600	0.38 ± 0.05 (in pH = 7.5)
POPOP (99+%), or 1,4-bis(5-phenyloxazol-2-yl) benzene	1806-34-4	Single-exponential lifetime standard	370–540	1.32 (in MeOH)
PPD (97%), or 2,5-diphenyl-1,3,4-oxadiazole	725-12-2	Single-exponential lifetime standard	310–440	1.20 (in EtOH)
PPO (99%), or 2,5-diphenyloxazole	92-71-7	Single-exponential lifetime standard	330–480	1.40 (in EtOH)
Rose Bengal (90%), or 4,5,6,7-tetrachloro-2',4',5',7'-tetraiodofluorescein	632-69-9	Single-exponential lifetime standard	560–680	0.98 ± 0.10
<i>p</i> -Terphenyl (99+%)	92-94-4	Single-exponential lifetime standard	310–410	1.05 (in EtOH)
Water (18-M Ω , de-ionized, triple-distilled)	7732-18-5	water Raman sensitivity test		

4: Optimizing Data Acquisition

Spectra can be enhanced by optimization of data acquisition. This chapter lists some methods of optimizing sample preparation, spectrofluorometer setup, and data correction to get higher-quality data.

Cuvette preparation

- 1 Empty all contents from the cuvettes.
- 2 Fully immerse and soak the cuvettes for 24 h in 50% nitric acid.

This cleans the cuvettes' inner and outer surfaces.



Note: Sample cells should be cleaned thoroughly before use to minimize background contributions.



Warning: Nitric acid is a dangerous substance. When using nitric acid, wear safety goggles, face shield, and acid-resistant gloves. Certain compounds, such as glycerol, can form explosive materials when mixed with nitric acid.

- 3 Rinse with deionized water.
- 4 Clean the cuvettes in the cleaning solution with a test-tube brush.

Use Alconox[®] or equivalent detergent as a cleaning solution.



Warning: Soaking the cuvettes for a long period causes etching of the cuvette surface, which results in light-scattering when the cuvettes are used.

- 5 Rinse the cuvettes with deionized water.
- 6 Soak the cuvettes in concentrated nitric acid.
- 7 Rinse them with deionized water before use.

Sample preparation

The typical fluorescence or phosphorescence sample is a solution analyzed in a standard cuvette. The cuvette itself may contain materials that fluoresce. To prevent interference, Jobin Yvon Inc. recommends using non-fluorescing fused-silica cuvettes that have been cleaned as described above.

Small-volume samples

If only a small sample volume is available, and the intensity of the fluorescence signal is sufficient, dilute the sample and analyze it in a 4-mL cuvette. If fluorescence is weak or if trace elements are to be determined, Jobin Yvon Inc. recommends using a capillary cell such as our 50- μ L or 250- μ L optional micro-sample capillary cells, which are specifically designed for a small volume. A 1-mL cell (5 mm \times 5 mm cross-section) is also available.

Solid samples

Solid samples usually are mounted in the Model 1933 Solid Sample Holder, with the fluorescence collected from the front surface of the sample (see *Components and Accessories*). The mounting method depends on the form of the sample.

- Thin films and cell monolayers on coverslips can be placed in the holder directly.
- Minerals, crystals, vitamins, paint chips, and similar samples usually are ground into a homogeneous powder. The powder is packed into the depression of the Solid Sample Holder. For very fine powder, or powder that resists packing (and therefore falls out when the holder is put into its vertical position), the powder can be held in place with a thin quartz coverslip, or blended with potassium bromide for better cohesion.

Dissolved solids

Solid samples, such as crystals, sometimes are dissolved in a solvent and analyzed in solution. Solvents, however, may contain organic impurities that fluoresce and mask the signal of interest. Therefore use high-quality, HPLC-grade solvents. If background fluorescence persists, recrystallize the sample to eliminate organic impurities, and then dissolve it in an appropriate solvent for analysis.

Biological samples

For reproducible results, some samples may require additional treatment. For example, proteins, cell membranes, and cells in solution need constant stirring to prevent settling. Other samples are temperature-sensitive and must be heated or cooled to ensure reproducibility in emission signals. (A thermostatted cell holder with a magnetic stirrer is available: See *Components and Accessories*).

Data collection techniques

Selecting the collection method

The two basic collection methods are right-angle and front-face. In right-angle detection, the fluorescence is collected at 90° to the incident exciting beam. Right-angle detection is used primarily for clear solutions. Front-face detection is used for optically dense solutions such as hemoglobin and for solid samples. In front-face detection, fluorescence is collected off the front surface of the cuvette or the solid sample. Inner-filter and re-absorption characteristics of opaque samples preclude right-angle detection. The optional front-face accessory for cuvettes is required for solutions. For solid samples, use the Model 1933 Solid Sample Holder.

Determining optimal wavelengths

The optimum excitation and emission wavelengths are known for many samples. If you are running a sample whose wavelength positions are unknown, you must determine these wavelengths to obtain the best possible results when you run the sample.

The method used to determine the excitation and emission wavelengths consists of first running an emission scan and observing the peak emission value. Once this value has been obtained, it is necessary to conduct an excitation scan using the peak emission value determined by running an emission scan.

Preliminary emission maximum

- 1 Verify that all system components are on.



Note: If you have not checked instrument performance, Jobin Yvon Inc. recommends acquiring a lamp spectrum and a water Raman spectrum, as outlined in the previous chapter, before proceeding.

- 2 Place the sample in the sample compartment.



Note: Make sure the lid is completely closed.

- 3 Enter the **Real Time Display**:

- 4 Turn on the high voltage to the signal detector.



Note: The default voltages will be used if the value is not changed.

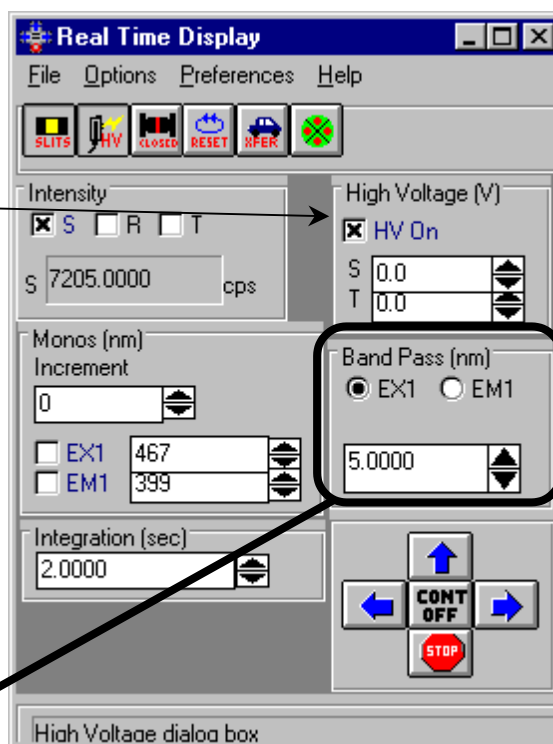

- 5 Set the excitation and emission slits to a bandpass of 5.0 nm.

After the value is entered, hit the Tab key on the keyboard to set the slits.

- 6 Close the **Real Time Display**.

The objective is to acquire a preliminary emission scan using an approximate excitation wavelength. Once the emission peak is determined, this value will be used to obtain the optimal excitation spectrum.

7 On the **Run Experiment** toolbar, choose the Experiment button: 

This opens the **Emission Acquisition** dialog box:

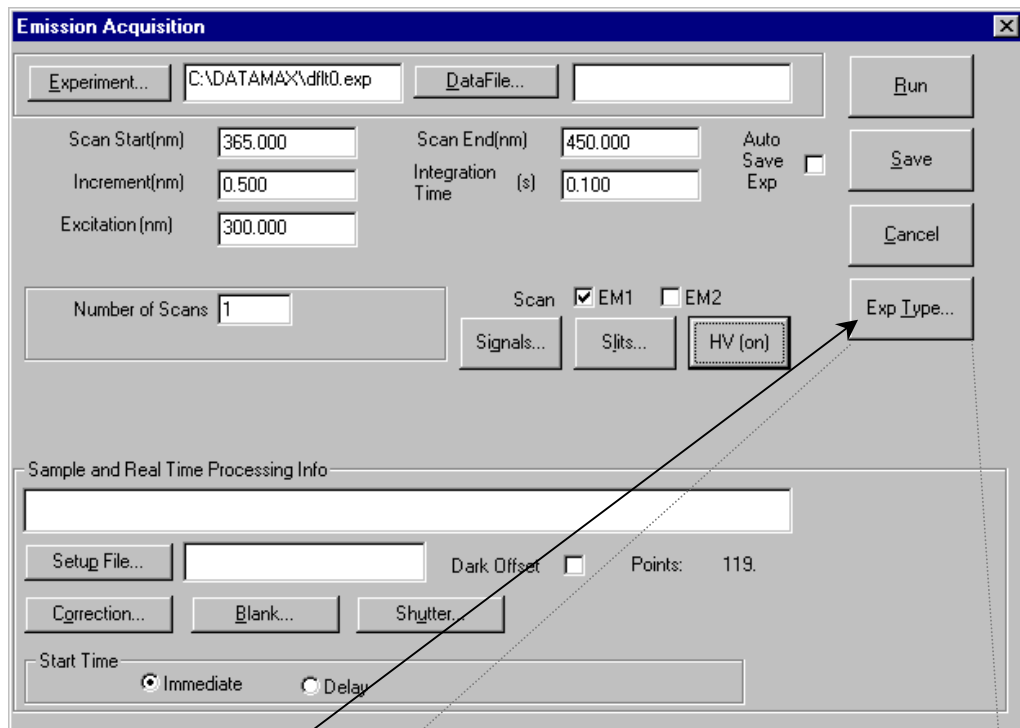

8 Click on **Exp Type....**

This opens the **Select Experiment Type** dialog box:

9 Choose **Emission Acquisition**.

Click **OK** to close the **Select Experiment Type** dialog box.

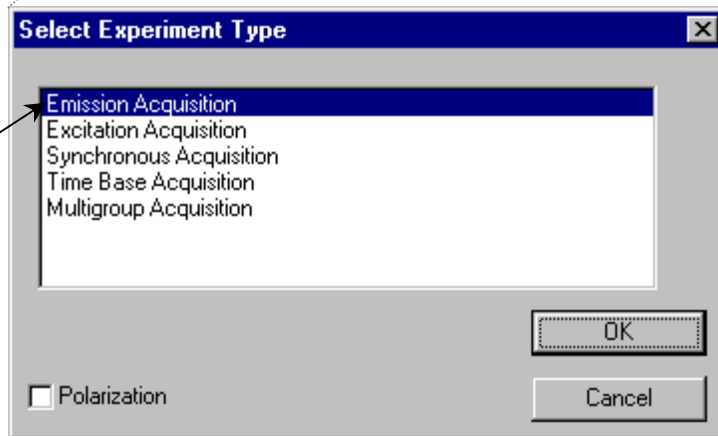

10 Specify the data acquisition parameters.

If unsure, try 300 nm,
 Add 15 nm to the exci-
 tation wavelength.
 Try 550 nm.

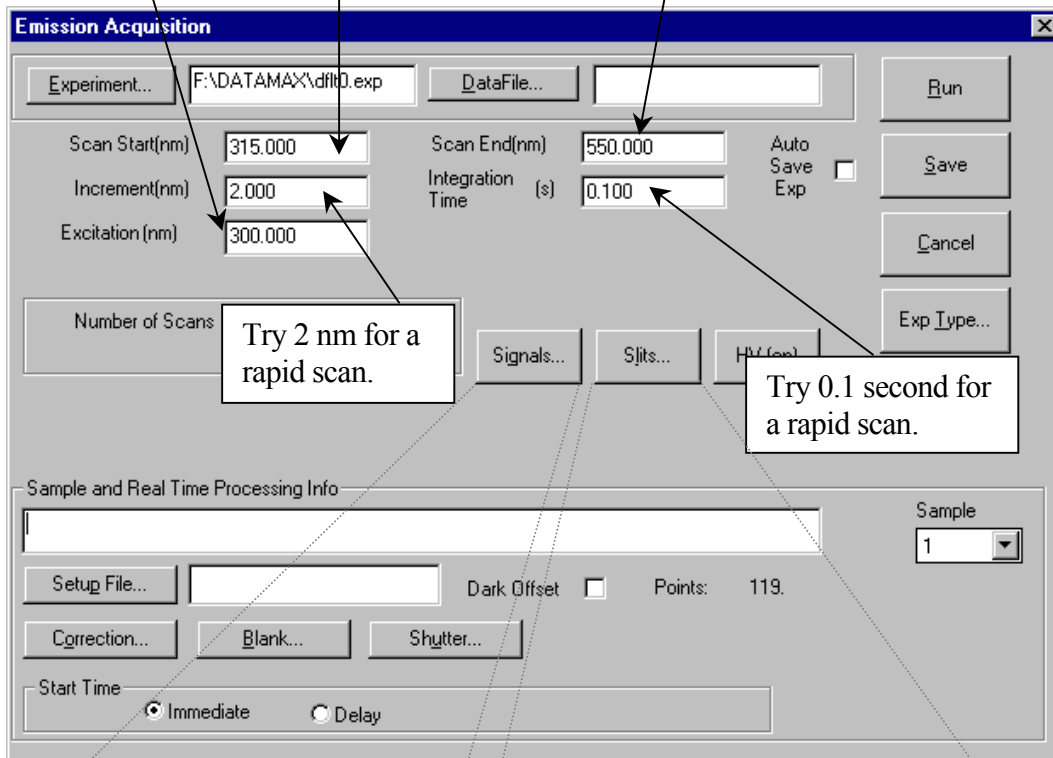

Try 2 nm for a rapid scan.

Try 0.1 second for a rapid scan.

a Click on **Signals...** to open the **Signals** dialog box:

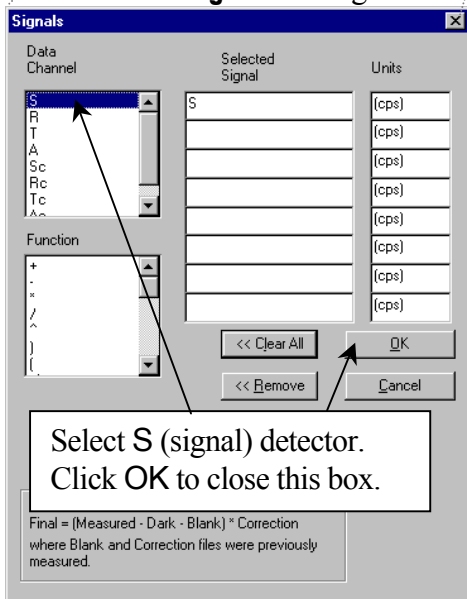

b Click on **Slits...** to open the **Slits** dialog box:

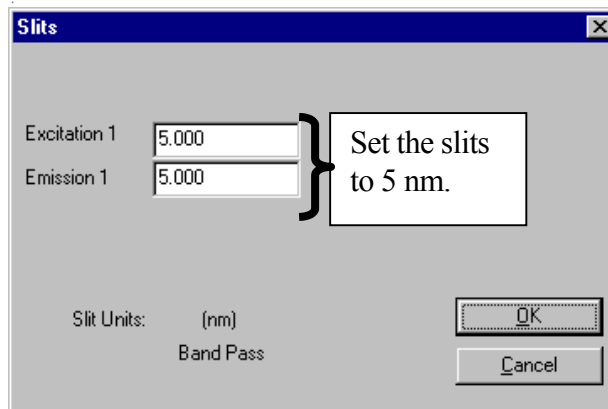

- 11 Enter the data file name and experiment file name, and any comments desired to distinguish this experiment from others.
- 12 Click Run to execute the experiment.
- 13 With the preliminary emission spectrum on the screen, note the greatest intensity.
- 14 Either
Record the wavelength at which this occurs. This is your emission maximum.



Note: If the signal level exceeds 2×10^6 cps, decrease the slit widths by 50%. If you do not see an obvious peak, increase the excitation wavelength and the starting and ending wavelengths by 25 nm, and acquire another emission scan.

Or

Repeat this procedure until you find an emission peak.

Excitation scan

The next step is to use the recently discovered emission maximum to determine the optimal excitation wavelength for the sample. The procedure is very similar to that outlined above.

- 1 On the **Run Experiment** toolbar, choose the **Experiment** button: 

As before, this opens the **Emission Acquisition** dialog box.

- 2 Click **Exp Type**.

This opens the **Select Experiment Type** dialog box.

- 3 Choose **Excitation Acquisition**.

Click OK to close the **Select Experiment Type** dialog box..

- 4 Specify the data acquisition parameters:

Try 250 nm.

Use the emission maximum from the previous procedure minus 15 nm. That is, if the emission maximum was 450 nm, use 435 nm.

Use the emission maximum from the previous procedure.

- 5 Click on the **Signals...** button.

This opens the **Signals** dialog box:

Enter S/R (Signal/Reference).
Using S/R produces a spectrum corrected for variations in lamp intensity with respect to time.

Click OK to close the **Signals** dialog box.

- 6 Enter the remaining parameters and, if desired, the data file name and the experiment file name, and any comments desired that will distinguish this experiment from others.

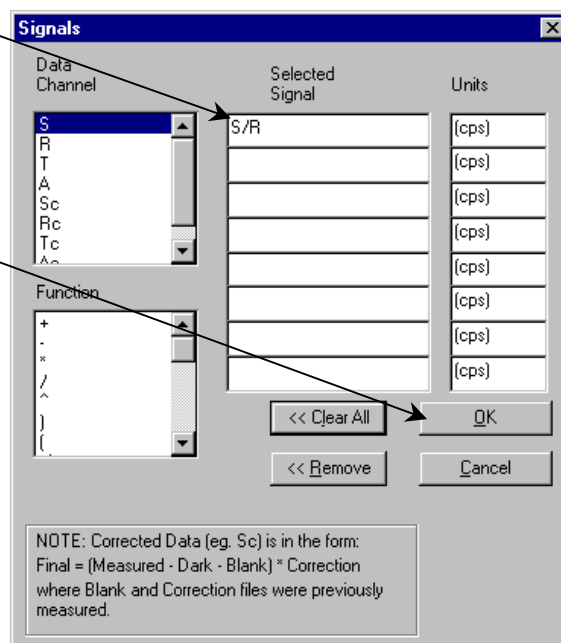

- 7 Click Run to execute the experiment.

The resulting spectrum displays intensity versus wavelength, and shows the maximum excitation wavelength.

Optimized excitation and emission spectra of a 1×10^{-8} -M anthracene solution are shown below. Because the acquisition modes were different for the excitation and emission scans, the data intensity had to be normalized. After normalization, notice that the excitation and emission scans are virtually mirror images of one another.

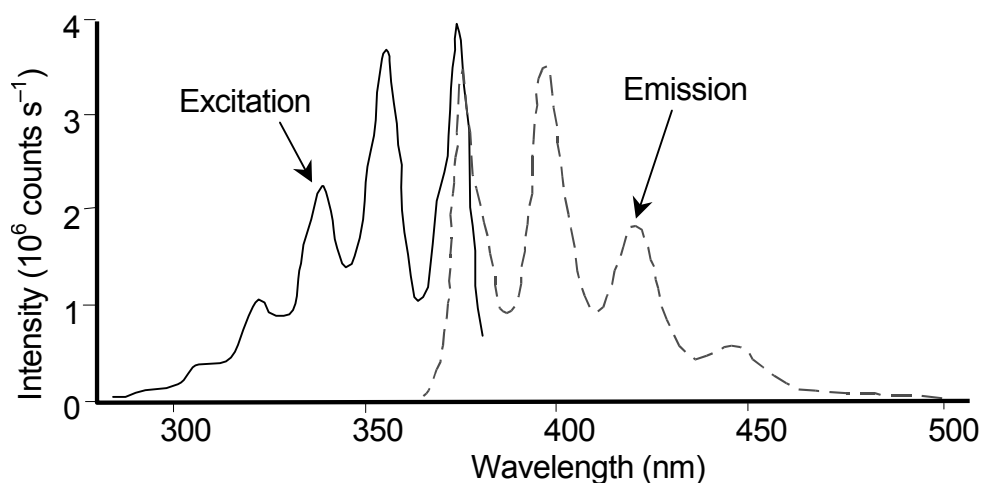

Normalized excitation and emission spectra of a 1×10^{-8} -M anthracene solution.

Measuring the G factor

The grating factor, or *G* factor, ought to be included anytime polarization measurements are taken. The *G* factor corrects for variations in polarization wavelength-response for the emission optics and detectors. A pre-calculated *G* factor may be used when all other experimental parameters are constant. In other cases, the system can measure the *G* factor automatically before an experimental run.



Note: Measure the *G* factor before a polarization experiment.

Constant Wavelength Analysis

Use **Constant Wavelength Analysis** to determine polarization at particular excitation/emission wavelength-pairs.

Use Polarization Modes checkbox activates acquisition parameters for polarizers. This brings up the **Polarizer Settings** dialog box for polarization, anisotropy, and raw polarization modes.

Proceed to Acquisitions opens the **New Polarization Sample** window:

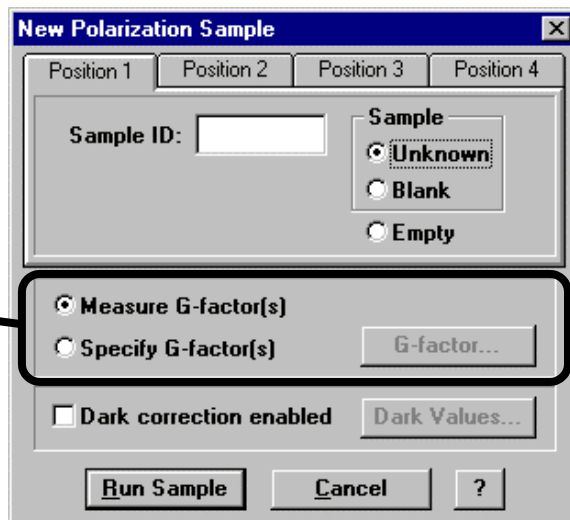

Either enter the *G* factor or have it measured automatically during the scan.



Note: For weak signals, enter the *G* factor, rather than measure it automatically. This may improve the S/N.

Run Experiment

For general experimental use of polarizers, use **Run Experiment**. Be sure that a layout including polarizers is loaded. When selecting the type of experiment, the **Polarization** checkbox must be active. A typical **Emission Acquisition** dialog box is as follows:

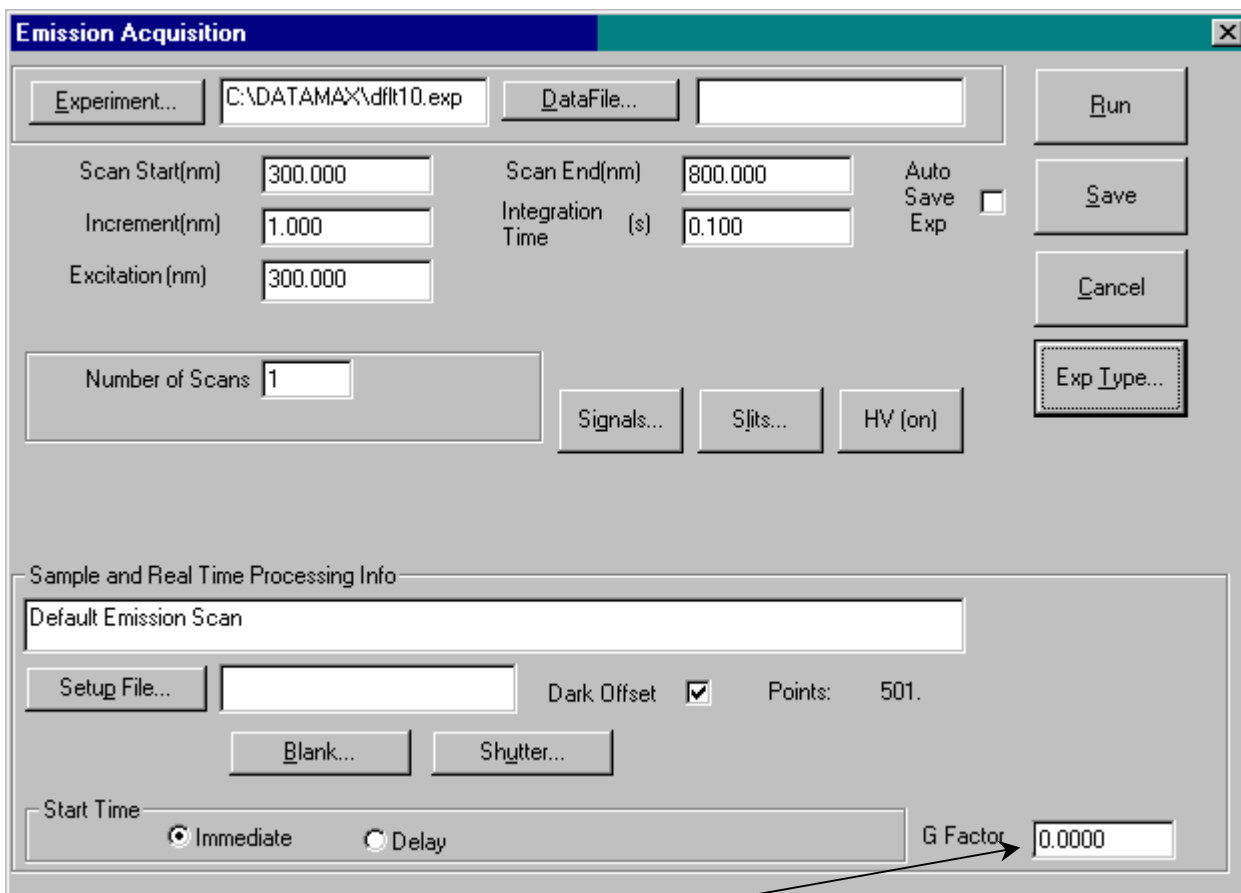

Note the *G* Factor field that appears.

- To measure the *G* factor automatically, set the field to 0.
- To use a pre-determined *G* factor, enter it here.

Faster scans with polarizers can be taken with Polar Scan.... Here, the *G* factor is entered in the **Quick Polarization** window:

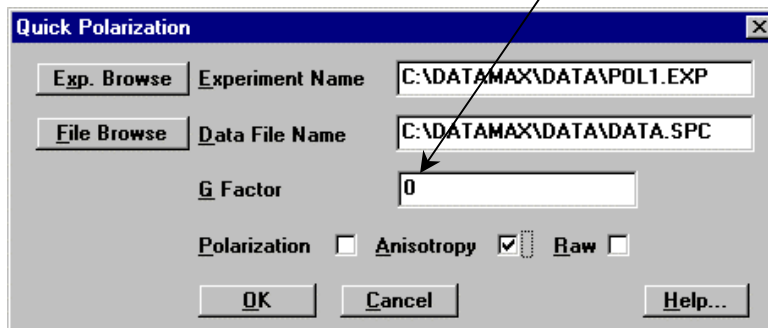

Quick Polarization

Exp. Browse Experiment Name C:\DATAMAX\DATA\POL1.EXP

File Browse Data File Name C:\DATAMAX\DATA\DATA.SPC

G Factor 0

Polarization Anisotropy Raw

OK Cancel Help...



Note: For detailed information on the *G* factor, see the Polarizers Operation Manual.

Improving the signal-to-noise ratio

Because of various hardware or software conditions, occasionally it is necessary to optimize the results of an experiment.

The quality of acquired data is determined largely by the signal-to-noise (S/N) ratio. This is true especially for weakly fluorescing samples with low quantum yields. The signal-to-noise ratio can be improved by:

- Using the appropriate integration time,
- Scanning a region several times and averaging the results,
- Changing the bandpass by adjusting the slit widths, and
- Mathematically smoothing the data.

The sections that follow discuss the alternatives for improving the S/N ratio and the advantages and disadvantages of each.

Determining the optimum integration time

The length of time during which photons are counted and averaged for each data point is referred to as the *integration time*. An unwanted portion of this signal comes from noise and dark counts (distortion inherent in the signal detector and its electronics when high voltage is applied). By increasing the integration time, the signal is averaged longer, resulting in a better *S/N* ratio. This ratio is enhanced by a factor of $t^{1/2}$, where t is the multiplicative increase in integration time. For example, doubling the integration time from 1 s to 2 s increases the *S/N* ratio by over 40%, as shown below:

For an integration time of 1 second,

$$\begin{aligned} S / N &= t^{1/2} \\ &= 1^{1/2} \\ &= 1 \end{aligned}$$

For an integration time of 2 seconds,

$$\begin{aligned} S / N &= t^{1/2} \\ &= 2^{1/2} \\ &\approx 1.414 \end{aligned}$$

or approximately 42%. Because *S/N* determines the noise level in a spectrum, use of the appropriate integration time is important for high-quality results.

To discover the appropriate integration time:

- a Find the maximum fluorescence intensity by acquiring a preliminary scan, using an integration time of 0.1 s and a bandpass of 5 nm.
- b From this preliminary scan, note the maximum intensity, and select the appropriate integration time from the table below.

Signal intensity (counts per second)	Estimated integration time (seconds)
1000 to 5000	2.0
5001 to 50 000	1.0
50 001 to 500 000	0.1
500 001 to 4 000 000	0.05

Integration time can be set either through **Run Experiment** for a specific experiment, **Real Time Display** to view the effects of different integration times on a spectrum, or **Visual Instrument Setup** to establish a default for all experiments. Refer to the software manual to learn more about setting the integration time.



Note: This table is only a *guide*. The optimum integration time for other measurements, such as time-base, polarization, phosphorescence lifetimes, and anisotropy, may be different.

Scanning a sample multiple times

Scanning a sample more than once, and averaging the scans together enhances the S/N ratio.

In general, the S/N ratio improves by $n^{1/2}$, where n is the number of scans.

To scan a sample multiple times, in an experiment dialog box, specify the number of scans in the **Number of Scans** field in **Run Experiment**. Refer to the software manual for detailed instructions regarding the data-entry fields of each type of experiment dialog box.

Selecting the appropriate bandpass

The bandpass (wavelength spread) affects the resolution of your spectra. If the bandpass is too broad, narrow peaks separated by a small change in wavelength may be unresolved. For example, for two 2-nm peaks 5 nm apart, and a bandpass of 10 nm, one broad peak, instead of two well-defined ones, will be visible.

By adjusting the slit widths, you can control the intensity and bandpass of the light. The slits of the excitation spectrometer determine the amount of light that will pass through the excitation spectrometer to the sample. The emission spectrometer slits control the amount of fluorescence recorded by the signal detector.

Bandpass can be calculated using the following formula:

$$\text{bandpass (nm)} = \text{slit width (mm)} \times \text{dispersion (nm/mm)}$$

The dispersion of the Fluorolog[®]-3 spectrofluorometer system depends upon the type of monochromator and the groove spacing of the gratings. For example, a Fluorolog[®]-3 with a single-grating monochromator and 1200 groove/mm gratings has a dispersion of 4.0 nm/mm, while a Fluorolog[®]-3 with a double-grating monochromator and 1200 groove/mm gratings has a dispersion value of 2.0 nm/mm. Below is a table listing various monochromators, installed gratings, and their respective dispersions.

Monochromator	Grating groove-density (grooves/mm)	Dispersion of the monochromator
Double	1200	2.1
	600	4.2
	300	8.4
Single	1200	4.2
	600	8.4
	300	16.8

Smoothing data

Smoothing the data improves the appearance of your spectrum. Smoothing, as are most post-processing features, is handled by GRAMS/32[®]. By selecting **Arithmetic** from the main menu of **Run Experiment**, you can choose **FFT** (fast-Fourier transform), **Binomial**, or **Savitsky-Golay** smoothing. Automatic smoothing and the degree to which smoothing occurs can be achieved by entering the **Peaks/Settings** dialog box and typing the relevant information. Refer to the *GRAMS/32[®] User's Guide* for additional information regarding smoothing data.

An additional option, **Zap**, for removing outliers, also appears under the **Arithmetic** menu. The *GRAMS/32[®] User's Guide* covers this option thoroughly.

In general, start with a 9- or 11-point smooth for a time-base measurement. To select the proper number of points for wavelength scan types, first locate the area that requires smoothing—usually this is a peak. Determine the number of data points used to make up the peak and then smooth the data using the number of points closest to this number. To avoid artificially enhancing the data, use the appropriate number of points to smooth the data. For example, selection of too large a number results in the background being smoothed into the peak.

Correcting data

Introduction

Collecting accurate information about the fluorescent or phosphorescent properties of a sample depends upon several factors:

- Equipment specifications
- Sample characteristics
- Timing considerations.

To ensure that the spectra collected indicate the actual properties of the sample and not external conditions, data often must be corrected. To *correct* data means to subtract information from the data not directly related to the properties of the sample. Gratings, detectors, and other spectrometer components have response characteristics that vary as a function of wavelength. These characteristics may be superimposed on spectra, thereby yielding a potentially misleading trace. For accurate intensity comparisons, such as those required for quantum-yield determinations, response characteristics must be eliminated. Supplied with the instrument are sets of excitation and emission correction factors to eliminate response characteristics. These files¹, `xcorrect` and `mcorrect`, are included with the software; copy them to your hard disk.



Note: The excitation range is 240–600 nm; the emission range is 290–850 nm.

Items that may be convoluted into a spectrum	Ways to remove these artifacts
Fluctuations caused by the light source	Monitoring lamp output using the reference detector, R, and using the signal ratio S/R to correct lamp profile or temporal fluctuations
Influence of the sample holder	Running a blank scan (which is then subtracted from the sample scan)
System hardware (e.g., optics, detectors).	Using radiometric correction factors

To use radiometric correction factors, either:

- Select the ones supplied with the program, or
- Select a set generated at your facility during or after acquisition, discussed in the following section. Acquiring radiometric correction factors is explained in Chapter 11: *Producing Correction Factors*.

Blank Subtraction and Dark Offset functions are described in the DataMax manual.

¹ Filenames include a three-letter extension. For the sake of clarity, we have omitted the extensions in this section. Refer to the software manual for specifics regarding extensions.

During acquisition

Data can be acquired either as raw data or as corrected data. A spectrum composed of raw data exhibits the effects of system parameters, while a corrected spectrum displays only the properties related to the sample. To automatically acquire corrected emission data, enter `mcorrect` in the Correction factor file field in the **Run Experiment** dialog box. To acquire corrected excitation data, enter `xcorrect`.



***Note:** Before applying correction factors, Jobin Yvon recommends subtracting the dark counts (because dark counts are not wavelength-dependent), and the spectrum of the blank, from the data. Refer to the software manual for specific instructions.*

After acquisition

To apply the correction factors after the data have been acquired, multiply the data file by the appropriate correction factor file (mcorrect or xcorrect).

- 1 Make sure the trace to be corrected is active in the **Run Experiment** window.

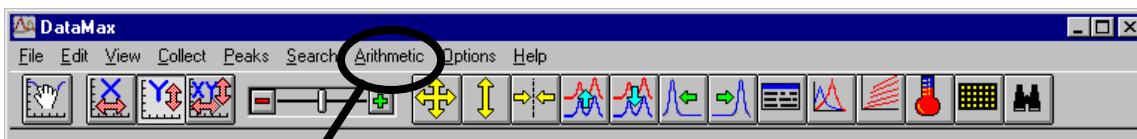

- 2 Select Arithmetic from the toolbar.

- 3 Select Functions.

This opens the **Math Functions** dialog box:

- 4 Next to Function, select Multiply.

- 5 Next to Operand, choose Term File*K.

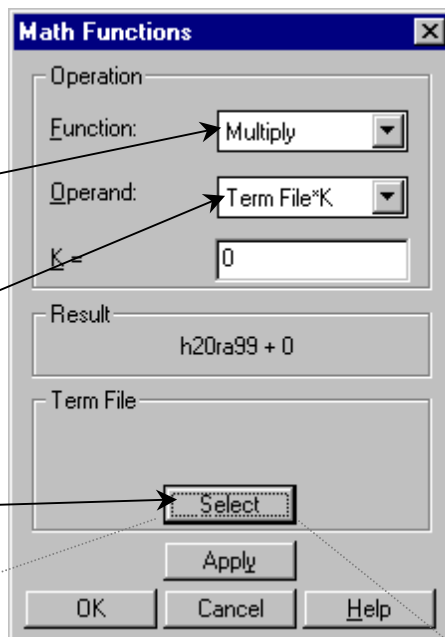

- 6 Click on the Select button.

This opens the **Select New Term File:** dialog box:

- 7 Select the appropriate file (mcorrect or xcorrect).

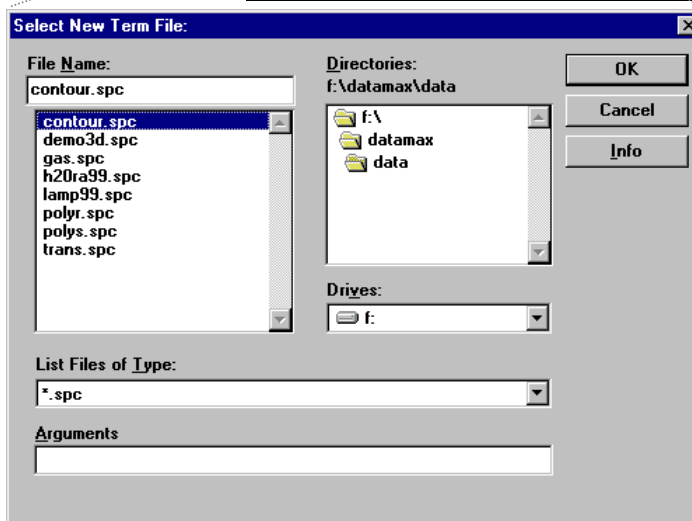

- 8 Click OK to close the **Select New Term File:**

dialog box.

The name of the file appears in the **Term File** area.

9 Click Apply.

The trace that appears on the screen is a result of the mathematical operation, giving a corrected spectrum.

5: System Maintenance

The Fluorolog[®]-3 spectrofluorometer requires very little maintenance. The outside panels may be wiped with a damp cloth to remove dust and fingerprints. The lamp is the only component that has to be replaced routinely. Regular examination of lamp and water-Raman spectra serves as an early indicator of the system's integrity. (These two tests are described in Chapter 3, *System Operation*.)

Xenon lamp

Obtaining good spectral results depends upon the xenon lamp. After 1700–2000 hours of use for the 450-W xenon lamp, the lamp output decreases significantly, indicating that the lamp should be replaced. Replacing the lamp within the specified time may prevent system failure. Jobin Yvon Inc. advises to keep a laboratory notebook near the Fluorolog[®]-3 to record lamp usage. Each time the lamp is turned on, it constitutes one full hour of use; therefore, Jobin Yvon Inc. suggests leaving the lamp on between brief periods of inactivity. Record the hours of use on the form in Chapter 9: *Xenon Lamp Information and Record of Use Form*.

Required tools

Tool	Size	Purpose
Allen wrench	5/32"	Screws for lamp power cables
Allen wrench	5/64"	Height adjustment; centering adjustment
Allen wrench	7/64"	Lamp support arm
Phillips screwdriver	Medium	Screws for top cover of housing

Replacement

The replacement xenon lamp is packed in the manufacturer's box and must be installed in the lamp housing. Read all the packing material including instructions and precautions before attempting to insert the lamp into the lamp housing.



Warning: Do not remove the protective cover from the replacement xenon lamp until instructed to do so.



Warning: Xenon lamps are an explosion hazard. Make sure the power is off and all AC power is disconnected from the system. Read and follow the cautions presented below.



Hazards

- ! Xenon arc lamps are an explosion hazard. Wear goggles and protective clothing when opening the lamp housing and when handling the lamp.
- ! The lamp power supply should not be connected to an AC power line while handling lamp leads. Lethal high voltages may exist.
- ! The lamp will remain extremely hot for approximately one-half hour after it has been turned off. Do not touch the lamp or the metal unit until the lamp has cooled.
- ! Never look directly at the xenon arc or its reflection. Intense radiation can permanently damage eyes.
- ! Do not touch the focusing lens, back scatter mirror, or the surface of the lamp. Fingerprints will be burned onto these surfaces when the lamp is ignited.

The following instructions are divided into three distinct procedures—each of which may be performed as a stand-alone operation:

- Open the lamp housing
- Remove the existing xenon lamp
- Install a new xenon lamp

To open the lamp housing:

- 1 Remove the 10 Phillips-head screws on top of the lamp housing.
- 2 Lift off the cover.

This exposes the lamp assembly:

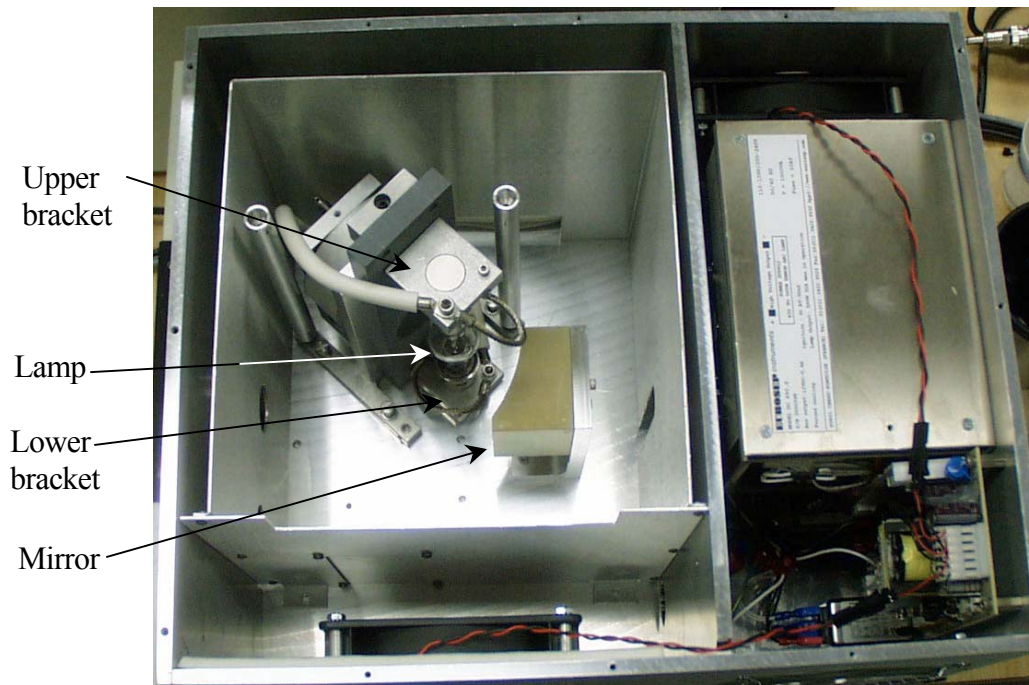

Top view of the lamp housing with cover removed.

To remove an existing lamp,

- 1 Remove the 5/32" cap screws from the upper and lower brackets, freeing the positive and negative power leads.

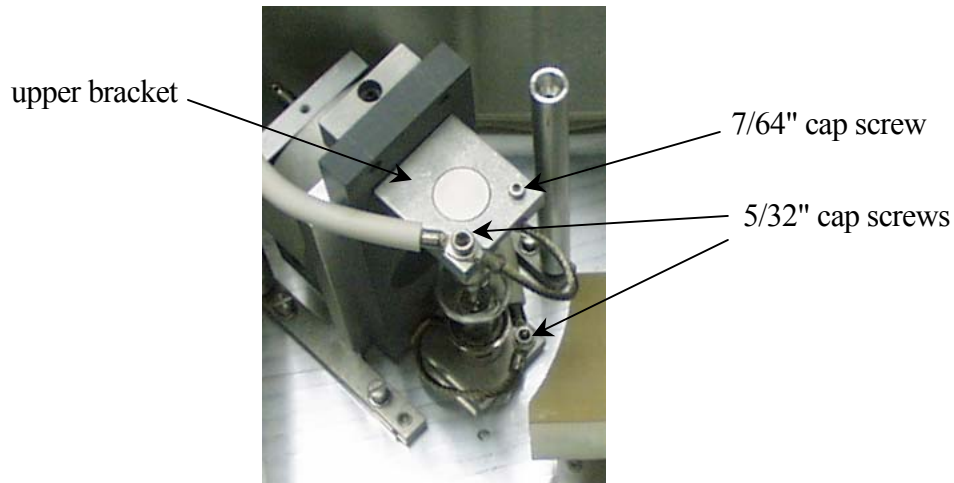

- 2 Remove the 7/64" cap screw from the upper bracket.
- 3 Remove the upper bracket.
- 4 Remove the lamp.
- 5 Place the protective cover around the xenon lamp.
- 6 Lock the cover into place.

Dispose of the spent xenon lamp, following all safety precautions and regulations.



To insert a xenon lamp

- 1 Be sure the cover of the lamp housing is removed.



Note: Jobin Yvon Inc. provides new bulbs with leads and connectors of the proper length and size. Other manufacturers' lamps may require extra adjustment before installation.

- 2 Pay attention to the polarity of the xenon lamp.

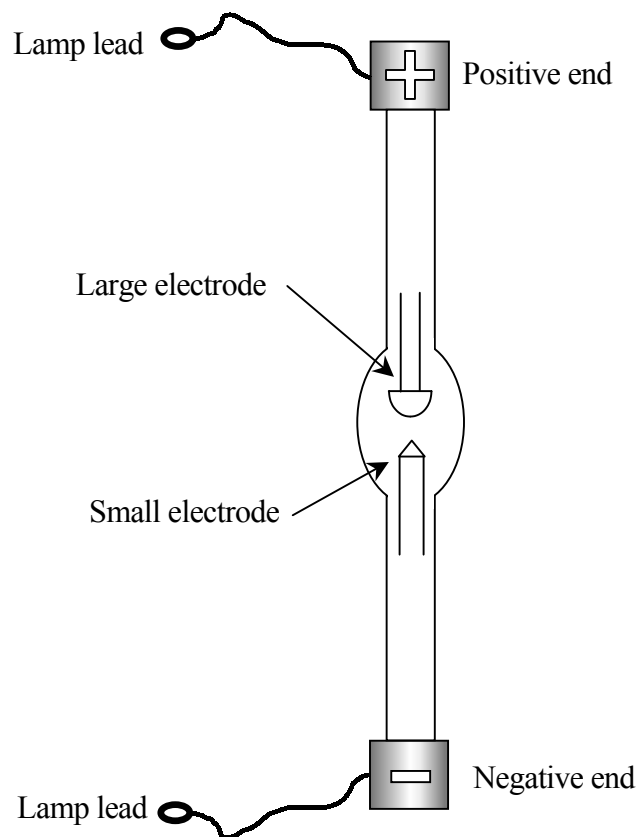

Diagram of lamp emphasizing polarity.

- 3 Seat the xenon lamp in the bottom bracket.

Make sure that the lamp is inserted all the way into the aluminum bracket. The negative end (marked with a “-”) should be downward.

- 4 Place the square aluminum upper bracket over the positive terminal of the bulb.

The positive end is marked with a “+”, and should be pointing upward.

- 5 Insert and tighten the 7/64" cap screw on the upper bracket.
- 6 Secure the upper lamp lead and upper power cable to the upper bracket, using a 5/32" cap screw.
- 7 Secure the lower lamp lead and lower power cable to the lower bracket, using a 5/32" cap screw.
- 8 Tighten these two 5/32" cap screws on the upper and lower brackets.
- 9 Pull the excess power cables away from the lamp assembly beneath the baffle.

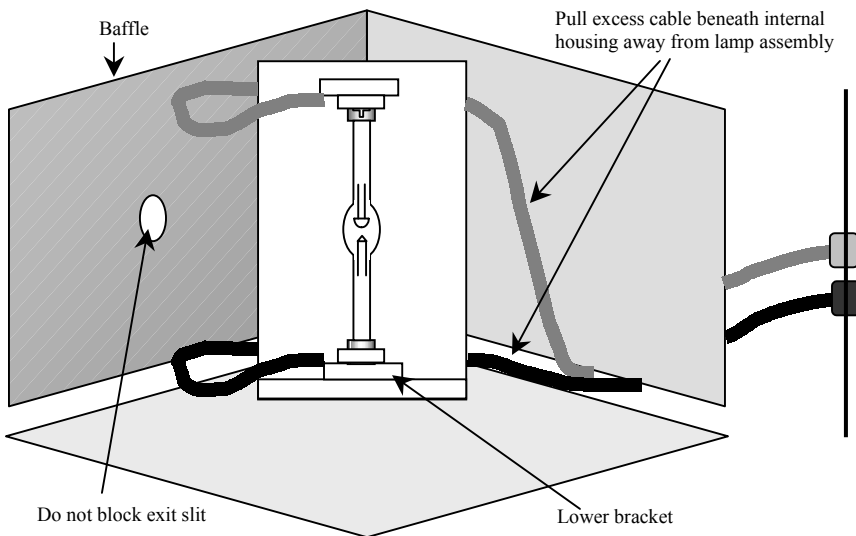
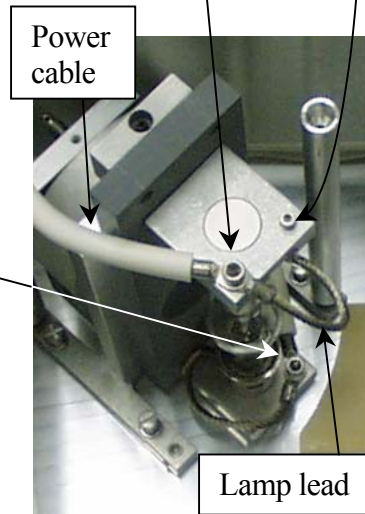

 **Note:** Make sure the cables do not block the exit slit of the lamp housing.

Diagram of lamp in place.

- 10 Replace the cover of the lamp housing and secure with the ten Phillips-head screws.

11 Plug the power cord from the lamp power supply into an outlet with the proper line voltage.



Warning: *DO NOT* operate this system from an ungrounded AC power source.



Note: *After installation, the lamp should burn in for 24 hours. After the burn-in, the lamp's position may be adjusted to optimize the signal intensity.*

Adjustment

Once the lamp is installed (and after a 24-hour burn-in period), it may need an adjustment to maximize the sensitivity of the Fluorolog[®]-3. To do this, Jobin Yvon Inc. recommends running a water Raman scan to check wavelength accuracy, and then monitoring the peak intensity while adjusting the vertical height of the lamp:

- 1 Insert a water-filled cuvette in the sample compartment.
- 2 Take a water Raman scan with the following parameters:

Excitation wavelength	350 nm
Scan range	365 nm to 450 nm
Increment	0.5 nm
Integration time	1.0 s
Slits	1.25 mm (single-grating spectrometer) 2.50 mm (double-grating spectrometer)
Acquisition mode	S

The water Raman peak intensity for the various Fluorolog[®]-3 spectrofluorometer systems are as follows:

Model	Intensity
FL3-11	>450 000 cps
FL3-12	>450 000 cps
FL3-21	>450 000 cps
FL3-22	>450 000 cps

Expected intensity for various systems.

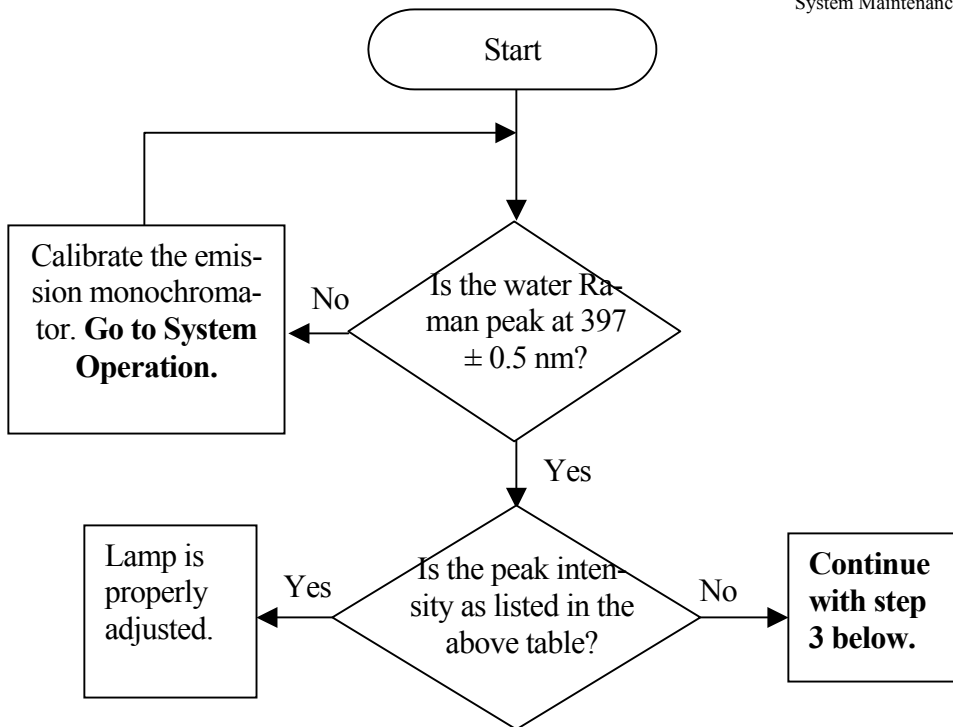

3 Enter the **Real Time Display** application.

4 Set the excitation and emission spectrometers to 350 nm and 397 nm, respectively.

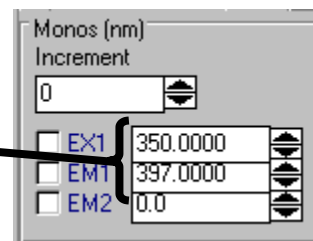

The Raman band's emission appears at 397 nm when water is excited using 350 nm.

5 Make sure HV1 is on and set to 950 V.

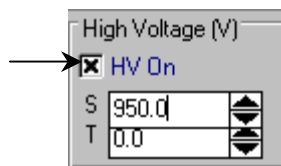

6 Open the programmable excitation shutter.

7 View the incoming data in acquisition mode S (signal detector).

Watch the signal intensity as you adjust the vertical position of the lamp. Therefore, position the monitor to see the changes while standing by the lamp housing.



Note: If the lamp is not at the best vertical position, correctly positioning the lamp will increase the signal significantly.

- 8 Insert a 5/64" Allen wrench inside the middle port on the top of the lamp housing.

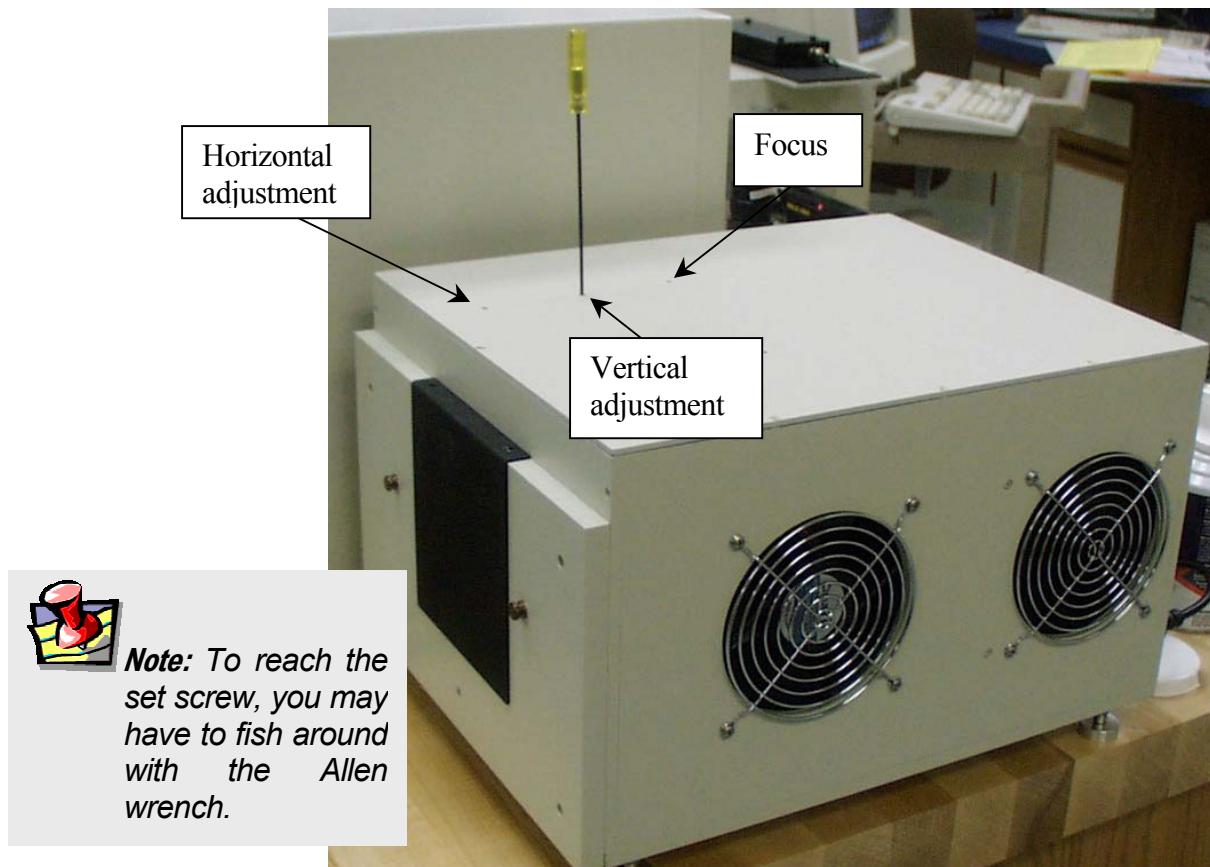

The Allen wrench is ready to adjust the vertical position of the lamp.

- 9 View the trace and make vertical adjustments by rotating the wrench either left or right to increase the signal.
- 10 Return to the **Run Experiment** application.
- 11 Re-scan the water Raman spectrum.

This should result in a clean scan at maximum intensity.



Note: If there is a problem, you may have to adjust the horizontal position of the lamp. This is rarely necessary, and should only be performed as a last resort.

- 12 Record the date that the new lamp was installed, as well as its maximum intensity.
- 13 Save the protective cover of the new bulb, for when the bulb must be replaced in the future.

Lamp housing

Clean the window in front of the lamp housing once a year, or more frequently if needed.



Note: Dust reduces the excitation light transmission, resulting in lower system sensitivity.

- 1 Remove 10 Phillips-head screws on the lamp housing's cover.
- 2 Lift off the cover of the lamp housing.
- 3 Remove the 2 screws that hold the baffle in place inside the housing.

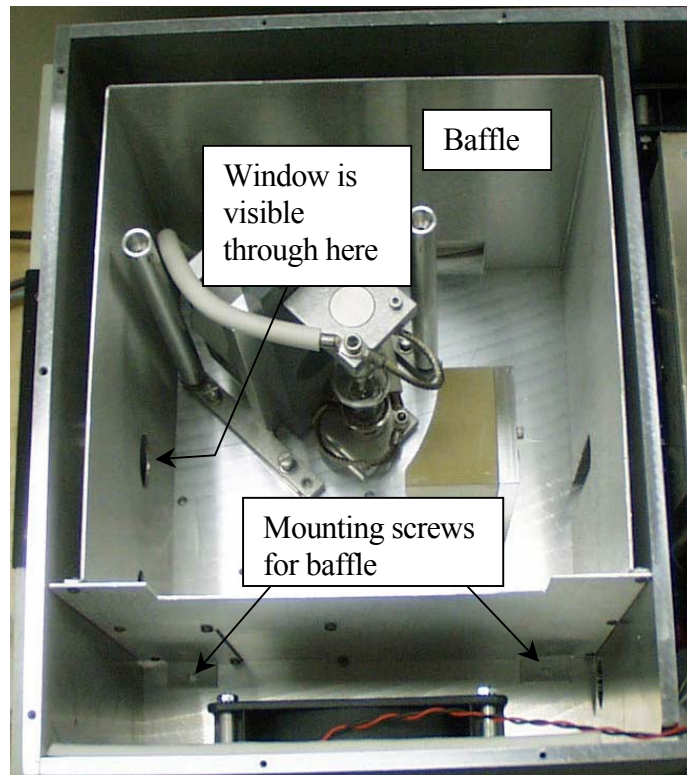

- 4 Carefully lift out the baffle from the housing.
- 5 If desired, remove the 2 cap screws holding the window in place.
- 6 Clean the window with lens tissue and methanol.



Cap screws on interior wall of lamp housing.

- 7 If the cap screws were removed, replace them.
- 8 Replace the baffle, and re-install the 2 screws holding it in place.
- 9 Re-install the cover, and secure it with the 10 Phillips-head screws.

Emission signal detector

There is a wide range of photomultipliers available to optimize different wavelength regions. When the R928P photomultiplier is replaced with a different detector, the emission correction factors must be updated (see Chapter 11: *Producing Correction Factors*).



Note: Fingerprints on the glass of the photomultiplier increase the dark count of the tube. Immediately remove fingerprints from the photomultiplier by rinsing with methanol and wiping with lens tissue.



Warning: Lethal high voltages are applied to the photomultiplier cathode. Turn off all instrument power before installing or removing a photomultiplier. Never expose a photomultiplier tube to room light while the high voltage is turned on.

To install a new R928P photomultiplier,

- 1 Be sure that the instrument power is turned off.
- 2 Be sure that a liquid-N₂-cooled PMT is warmed to room temperature.
- 3 Remove the cables and wires attached to the tube.
- 4 Carefully lift the tube from its base socket.
- 5 Remove the protective cap from the new photomultiplier.
- 6 Plug the photomultiplier into the base socket.
Make sure the photomultiplier is positioned all the way down on the socket.
- 7 Carefully slide the photomultiplier into the base socket.
- 8 Connect the cables.

This is outlined in the “Cable Connections” section in Chapter 13: *Re-assembly Instructions*.

Reference signal detector

The reference signal detector is a state-of-the art silicon diode that requires no routine maintenance.

Gratings

The excitation and emission spectrometer gratings are 1200 grooves/mm, and are blazed at 330 nm and 500 nm, respectively. If an application requires that the system be optimized for a particular region, the gratings can be changed by following a simple procedure.

Required tools

Tool	Size	Purpose
Phillips screwdriver	medium	Top cover.
Lid support	--	Supports the lid in an open position.

Replacement

Gratings require no routine maintenance. To use a grating with different specifications than those installed in the system, replace the existing ones.



Warning: Never touch the diffraction surface of a grating.

Jobin Yvon Inc. recommends that you never attempt to clean off any dust on the gratings and mirrors. The effect of cleaning may cause more problems than the dust. The surface is easily marred and cannot be cleaned the way a mirror can.



Warning: Do not loosen the mirror mounts.

Mirrors in the spectrometers have been aligned at the factory. If mirror realignment is necessary, contact the Spex[®] Fluorescence Service Department. Typically, mirror realignment requires special targets and fixtures, and a laser.

Remove the existing grating

- 1 Close the slits in the emission spectrometer.
- 2 Turn off all instrument power.
- 3 Remove the Phillips-head screws holding the lid on the monochromator.

- 4 Lift the lid slowly until you feel resistance.



Warning: A circuit board and critical connections are attached to the lid of the spectrometer. DO NOT attempt to lift the lid completely off.

This is the maximum length of the cables attached to the lid.

- 5 Insert the lid support at the rear of the monochromator.
- 6 Place the lid in the support.

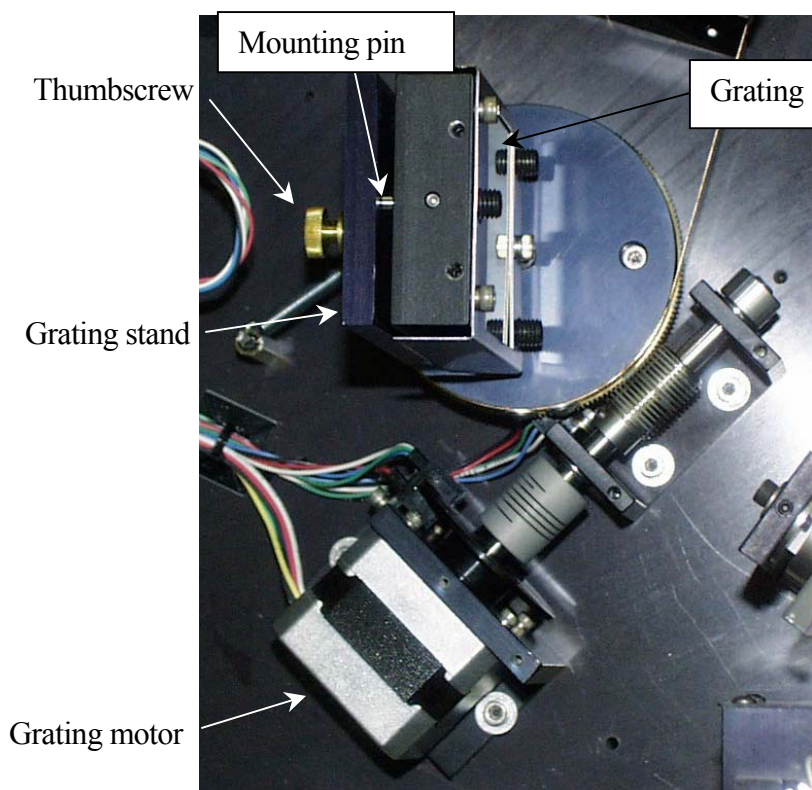

Overhead view of the grating assembly.

7 Release the grating from the stand.

- a Loosen the thumbwheel screw securing the grating to the grating stand.



Back view of grating assembly.

- b Pull the grating away from the stand.

To insert a new grating,

- 1 Place the 3 mounting pins on the back of the grating into the matching mounting slots on the grating stand.
- 2 Tighten the thumbscrew on the back of the grating stand.
- 3 Lift the lid of the spectrometer off of the lid mount.
- 4 Remove the lid mount.
- 5 Place the lid on the spectrometer.
- 6 Secure the lid with the Phillips screws.

No further adjustments or alignments are necessary.

Mirrors

Mirrors are aligned at the factory and usually do not need realignment. Only the Model 1692M Selection Mirror (an option) can be adjusted easily to optimize the fluorescence signal from the sample. This mirror should be adjusted periodically if low signal is caused by poor alignment at the slit position.



Warning: Adjust the mirrors *only if a laser is available* to check the alignment. Misalignment will destroy the similarity of the right-angle and front-face light paths in the single-beam sampling module. (Front-face capability is an option in the T-Box.)

Improperly moving any of the mirrors in the spectrometers will reduce resolution capability and refocusing will be required. If the system becomes misaligned, contact the Spex[®] Fluorescence Service Department to arrange for a service visit.

Automated 4-position turret

If a circulating bath is used to regulate the turret's temperature, periodically replace the fluids in the bath.



Note: Over time, bacteria can grow in the temperature bath, or the water can become hard.

6: Components & Accessories

The Fluorolog[®]-3 can be configured to obtain optimum results for a variety of applications. The basic system, regardless of configuration, consists of slits, detectors, a xenon lamp with power supply, and a sampling module. These items can be combined in different ways to provide maximum benefits.

The following list represents all the accessories and components (including those mentioned above), in alphabetical order, available for the Fluorolog[®]-3 spectrofluorometers. A brief description of each is included in the following sections. Like the list presented below, the descriptions that follow are alphabetized, except where logical order dictates otherwise.

For additional information or product literature on any of these items, contact your local Jobin Yvon Inc. Sales Representative.

Itemized List

Fluorolog®-3 Accessories

Item	Model	Page
Accessory, Absorption/Transmission	1940	6-3
Adapter, Micro Cell (See Cell, Micro)	1923A	
Adapter, Micro Cell (See Cell, Micro)	1924A	
Assembly, Liquid Nitrogen Dewar	FL-1013	6-6
Assembly, Scatter Block	1908MOD	6-7
Assembly, Standard Lamp	1908	6-7
Cell, HPLC Flow	1955	6-8
Cell, Micro	1923	6-8
Cell, Micro	1924	6-8
Cell, Quartz	1925	6-8
Cell, Sample	1920	6-8
Cell, Sample (Reduced Volume)	QC-SK	6-8
Detector, Reference Photodiode	1967	6-9
Detector, Signal CCD	various	6-10
Detector, Signal: Room Temperature Photomultiplier	1911F	6-11
Detector, Signal: Thermoelectrically Cooled Housing	1914F	6-12
Detector, Signal: Thermoelectrically Cooled Near-IR PMT	FL-1030	6-13
Dewar, Liquid Nitrogen (See Assembly, Liquid Nitrogen Dewar)	1932D	
Fiber Optic Mount	F-3000	6-14
Filter, Cut-On (1" × 2")	1938	6-15
Filter, Cut-On (2" × 2")	1939	6-15
Front-Face Viewing Option	FL-1001	6-16
Gratings	various	6-17
Holder, Filter	FL-1010	6-18
Holder, Four-Position Variable Temp. Control w/ Magnetic Stirrer	FL-1011	6-19
Holder, Dual-Position Variable Temp. Control w/ Magnetic Stirrer	FL-1012	6-21
Holder, Solid Sample	1933	6-23
Housing, Xenon Lamp	FL-1039	6-25
Housing, Dual Lamp	FL-1040	6-25
Injector, Autotitration	F-3005/6	6-26
Interface, Microscope Fiber-Optic (Nikon)	F-3001	6-27
Interface, Microscope Fiber-Optic (Olympus)	F-3002	6-27
Interface, Microscope Fiber-Optic (Zeiss)	F-3003	6-27
Lamp, Xenon 450-W	1907	6-28
Peltier Drive, Sample Heater/Cooler	F-3004	6-29
Phosphorimeter Accessory	FL-1042	6-30
Plate Reader	MicroMax	6-31
Polarizer, L-Format	FL-1044	6-32
Polarizer, T-Format	FL-1045	6-32
Port, Injector	FL-1015	6-33
Temperature Bath	F-1000/1	6-34
Trigger Accessory, External	TRIG-15/25	6-35

Model 1940 Absorption/Transmission Accessory

The Model 1940 Absorption/Transmission Accessory slightly displaces the sample from its normal position and directs the transmitted light into the collection optics with a mirror mounted at 45°.

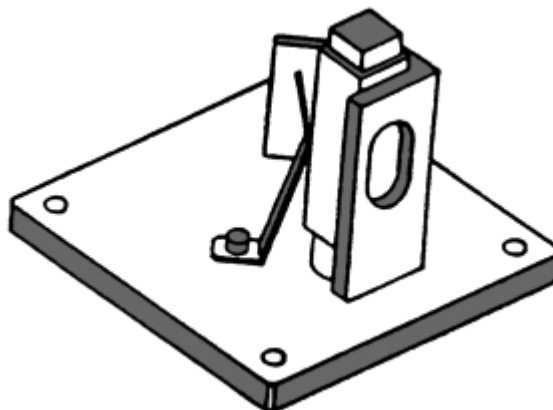

Model 1940 Absorption/Transmission Assembly.

Operation of the Model 1940 Accessory requires two steps:

- a Installation
- b Optimization of the emission and reference signals

Installation

- 1 Remove the sample holder currently in place.
- 2 Position the Model 1940 on the posts.
- 3 Tighten the two thumbscrews.

Before you acquire transmission or absorption spectra, the emission and reference signals must be optimized.

Signal optimization

- 1 Select right-angle detection.
Turn the selection knob to RA.

- 2 Place the cuvette containing the blank in the sample holder.
- 3 Set the emission spectrometer position to 0 nm.
- 4 Select acquisition mode *S/R*.
- 5 Run an excitation scan over the absorption range of the sample.



Note: If uncertain of the absorption range, enter a range of 250 nm to 400 nm, and scan the excitation spectrometer. Detailed instructions for setting parameters are contained in the software manual. The S/R acquisition mode compensates for fluctuations in lamp intensity, and wavelength dependency of the lamp and excitation spectrometer.

- 6 Note the emission signal at maximum transmission of the blank.
- 7 Adjust the slits to maximize the signal without saturating the detector.



Note: The linear range of the R928P detector operated in the photon-counting mode is 2 million cps.

- 8 Similarly, locate the maximum reference signal of the lamp spectrum.
- 9 Set the excitation spectrometer to that position.



Warning: Only when both emission and reference signals are within prescribed limits should you proceed with the measurements.

10 Adjust the high voltage HV2, as needed, so that the reference signal is $\sim 1 \mu\text{A}$ (saturation of the reference detector is $10 \mu\text{A}$).

11 Acquire transmission spectra.

Either

- a Position the emission spectrometer at 0 nm, and use the S/R acquisition mode.
- b Acquire an excitation scan of the blank.
- c Acquire an excitation scan of the sample.

Or

When the spectrometers are synchronously scanned using an offset of 0 nm, the emission slits should be opened five times as wide as the slits of the excitation spectrometer.

- d Acquire a synchronous scan with an offset of 0 nm over the absorption range of the blank.
- e Acquire a synchronous scan with an offset of 0 nm over the absorption range of the sample.



Note: If the detectors are saturated, close the slits a little or install a neutral-density filter.

12 Calculate the absorption.

The absorption spectrum can be determined from the following equation:

$$A = \log(S/R)_{\text{blank}} - \log(S/R)_{\text{sample}}$$

FL-1013 Liquid Nitrogen Dewar Assembly

For phosphorescence or delayed fluorescence measurements, samples are often frozen at liquid-nitrogen temperature (77 K) to preserve the fragile triplet state. The sample is placed in the quartz cell and slowly immersed in the liquid-nitrogen-filled Dewar flask. The white Teflon[®] cone in the bottom of the Dewar flask keeps the quartz sample-tube centered in the Dewar flask. The Teflon[®] cover on the top of the Dewar flask holds any excess liquid nitrogen that bubbled out of the assembly. A pedestal holds the Dewar flask in the sampling module. A special stove-pipe sample cover replaces the standard sample lid, so that liquid nitrogen can be added to the Dewar flask as needed. The Dewar flask holds liquid nitrogen for at least 30 min with minimal outside condensation and bubbling.



FL-1013 Liquid Nitrogen Dewar Assembly.

Included in the FL-1013 Liquid Nitrogen Dewar Assembly, the Dewar flask can be purchased as a spare. The bottom portion, which sits directly in the light path, is constructed of fused silica.



Note: If condensation appears on the outside of the Dewar flask, it must be re-evacuated.

Model 1908MOD Scatter Block Assembly

The Scatter Block Assembly includes a white scatter block assembly and a clamp holder for use with a user-supplied standard lamp and regulated power supply.

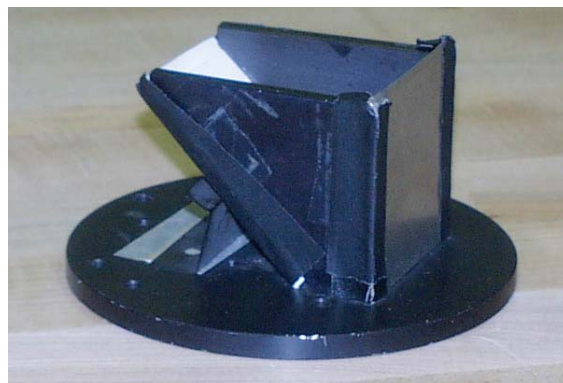

Model 1908MOD Scatter Block Assembly.

Model 1908 Standard Lamp Assembly

The Model 1908 Standard Lamp Assembly is a complete correction factor kit used to generate radiometric emission correction factors for the spectrofluorometer systems. The assembly includes:

- an NIST-traceable, calibrated, 200-W quartz tungsten-halogen lamp with irradiance values.
- Regulated 6.5-A power supply with lamp holder
- 1908MOD Scatter Block Assembly (see above)

Emission correction factors compensate for the response of the photomultiplier detector as well as the wavelength dependency of the gratings in the emission spectrometer. Emission correction factors should be updated periodically and whenever different gratings or a new signal detector is installed. The procedure for generating new correction factors is contained in Chapter 11.

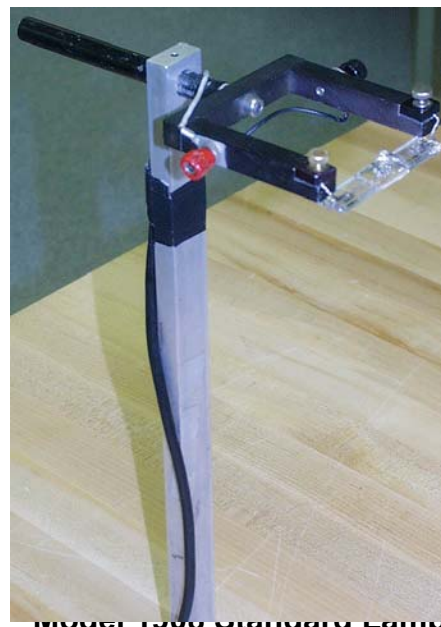

Model 1908 Standard Lamp Assembly.

Sample Cells

Model 1955 HPLC Flow Cell

With a sample capacity of 20 μL , this non-fluorescing fused silica cell is ideal for on-line monitoring of fluorescent samples. The cell maintains high sensitivity because it has a large aperture for collecting the excitation light to the sample and fluorescence emission from the sample. The flat sides allow maximum throughput while keeping the scattering of the incident radiation to a minimum. The cell fits in a standard cell holder.

Model 1923 Micro Cell (with Model 1923A Adapter)

This non-fluorescing fused silica cylindrical cell holds 50 μL . This cell will not accept a magnetic stirrer. The 1923A Adapter is required to be able to mount in a standard 10 mm by 10 mm cell holder.

Model 1924 Micro Cell (with Model 1924A Adapter)

This non-fluorescing fused silica cylindrical cell holds 250 μL . A magnetic stirrer cannot be used with this cell. The 1924A Adapter is required to enable mounting in the standard 10-mm- \times -10-mm cell holder.

Model 1925 Quartz Cuvette

With a 4-mL volume, this cell measures 10 mm \times 10 mm in cross-section, and comes with a Teflon[®] stopper to contain volatile liquids.

Model 1920 Sample Cell

This 2-mL to 4-mL non-fluorescing fused silica cell, capable of accepting a magnetic stirrer, has a 10-mm path length and includes a white Teflon[®] cap that prevents sample evaporation.

Model QC-SK Reduced Volume Sample Cell

This non-fluorescing fused silica cell is selected for samples with a maximum volume of 1 mL. The square cross-section of the sample cavity is 5 mm. The precise imaging capability of the excitation light focused onto the sample allows for high sensitivity. The adapter and a “flea” magnetic stirrer are included.

Model 1967 Photodiode Reference Detector

The Photodiode Reference Assembly monitors the xenon lamp up to 1 μm . This accessory is standard in the Fluorolog[®]-3 package, but a photomultiplier can be substituted instead (necessary for phosphorescence measurements).

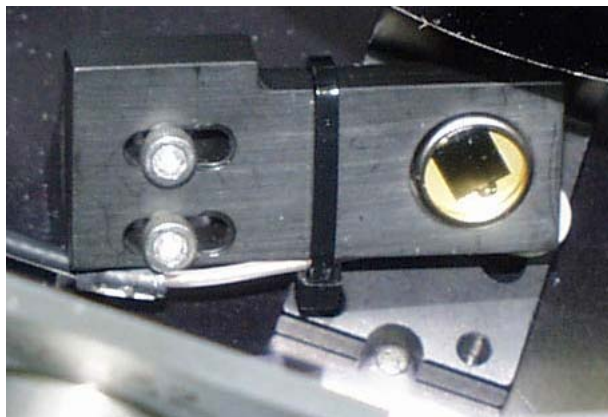

Model 1967 Photodiode Reference Assembly.

CCD Detectors

For multichannel spectral acquisition, many charge-coupled devices are available to suit the researcher's needs. Both air-cooled and liquid-nitrogen-cooled CCDs can be inserted into the Fluorolog[®]-3. Available options include extended-UV and near-IR detection, various pixel sizes and arrays, and maximum-coverage options. Contact a local Sales Representative for details and specific model numbers.

Model 1911F Room Temperature Signal Detector

The Fluorolog[®]-3 includes a room temperature R928P emission signal detector. This detector is mounted to the emission spectrometer and operated in the photon-counting mode.

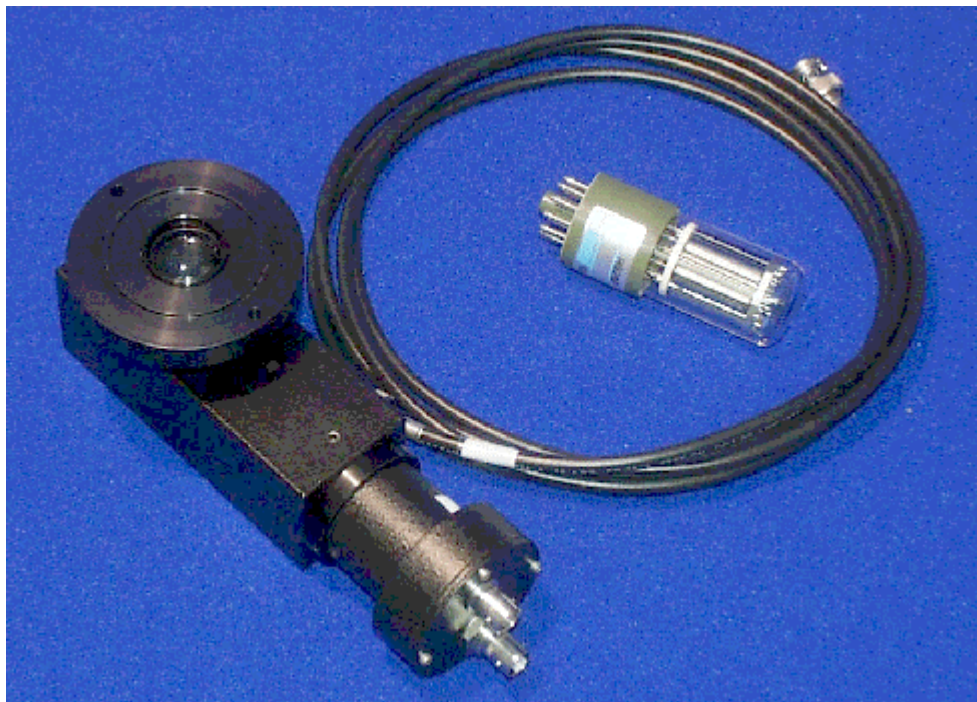

Model 1911F Room-Temperature Signal Detector.

The dark count is specified at <math><1000</math> cps, and the R928P delivers useful output from 190 nm to 860 nm.

Model 1914F Thermoelectrically Cooled Signal Detector

As a rule, cooling a detector improves the S/N ratio by reducing the inherent dark count or noise. For the standard signal detector, Model 1911F (described above), cooling reduces the dark count from 1000 cps to 20 cps; the useful wavelength band (190–860 nm) remains the same.

The Thermoelectrically Cooled Signal Detector consists of the housing, power supply, Model 1630 Field Lens Adapter, a black flange, and a silver adapter plate. To cool, a water line and drain are attached to the tubing extending from the housing, and room-temperature water is circulated through the housing.



Model 1914F Thermoelectrically Cooled Signal Detector R928P.

FL-1030 Thermoelectrically Cooled Near-IR Photomultiplier Tube

For spectral measurements extending into the near-infrared, the FL-1030 Thermoelectrically Cooled PMT is perfect. Included in the FL-1030 is the thermoelectrically cooled housing. The InGaAs detector has a spectral range from 250 nm all the way to 1050 nm. Required for this item is the DM302 Photon Counting Module.

F-3000 Fiber Optic Mount

Now you can study marine environments, skin and hair, or other large samples *in situ*! For those users who want to examine samples unable to be inserted into the sample compartment, the F-3000 Fiber Optic Mount (plus fiber-optic bundles) allows remote sensing of fluorescence. The F-3000 couples to the T-box; light is focused from the excitation spectrometer onto the fiber-optic bundle, and then directed to the sample. Fluorescence emission from the sample is directed back through the bundle and into the front-face collection port in the sample compartment. Randomized fiber optic bundles ranging in length from 1 meter to 5 meters are available. Contact the local Jobin Yvon Inc. Sales Representative for details.

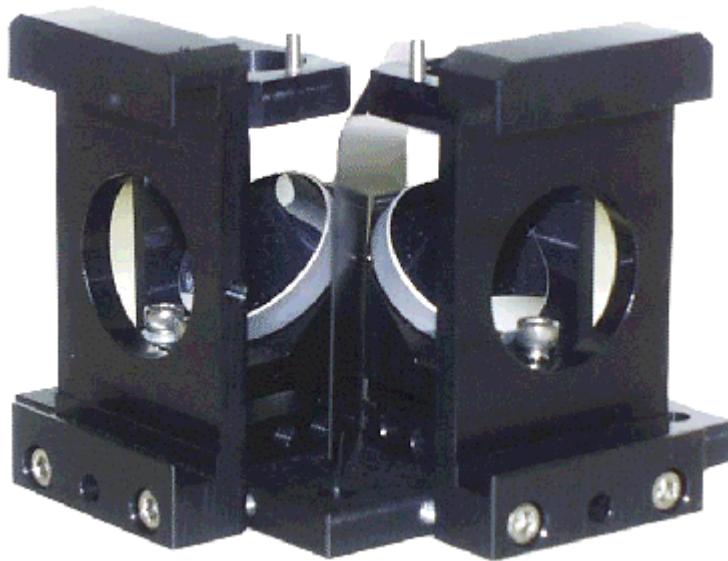

F-3000 Fiber Optic Mount.

Model 1938 Cut-On Filter

The Model 1938 Cut-On Filter Set consists of 5 filters with dimensions of 1" × 2". To properly position the filter, the Model FL-1010 Filter Holder is required.

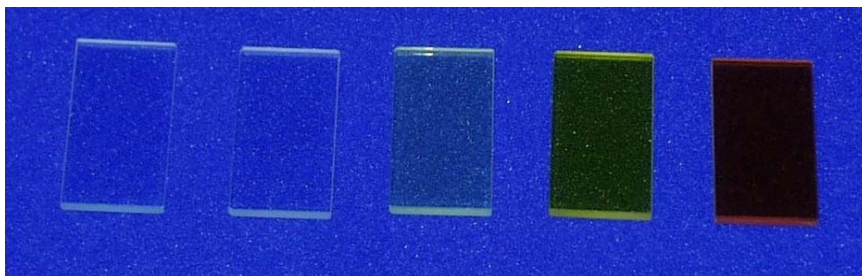

Cut-on filters are used to eliminate second-order effects of the gratings. For example, if sample excitation is at 300 nm, a second-order peak occurs at 600 nm. If the emission spectrum extends from 400 nm to 650 nm, a sharp spike occurs at 600 nm. This peak is the second-order peak of the excitation spectrometer. To remove this unwanted peak in the emission spectrum, place a 350-nm filter in the emission slot. Cut-on filters typically are used for phosphorescence measurements, where second-order effects are likely to be found.

The single-beam and T-box sampling compartments have three slots that can hold the Model FL-1010 filter holder. One slot is in the excitation light path and the other two are the emission light path positions. To eliminate second-order effects from an excitation spectrum, install the filter holder and the appropriate cut-on filter in the excitation light path.

Model 1939 Cut-On Filter

The Model 1939 Cut-On Filter set consists of five 2" × 2" filters with cut-on wavelengths of 350 nm, 399 nm, 450 nm, 500 nm, and 550 nm. To properly position the filter, the FL-1010 Filter Holder is required.

Cut-on filters are used to eliminate second-order effects of the gratings. For example, if sample excitation is at 300 nm, a second-order peak occurs at 600 nm. If the emission spectrum extends from 400 nm to 650 nm, a sharp spike occurs at 600 nm. This peak is the second-order peak of the excitation spectrometer. To remove this unwanted peak in the emission spectrum, place a 350-nm filter in the emission slot. Cut-on filters are typically used for phosphorescence measurements, where second-order effects are likely to be found.

The single-beam and T-box sampling compartments have three slots that can hold the FL-1010 filter holder. One slot is in the excitation light path and the other two are the emission light path positions. To eliminate second-order effects from an excitation spectrum, install the filter holder and the appropriate cut-on filter in the excitation light path.

FL-1001 Front-Face Viewing Option

Designed to examine fluorescence from the surface of solid samples, the FL-1001 Front-Face Viewing Option includes a swing-away mirror. This allows the researcher to change from front-face and right-angle data collection instantly. In the front-face collection mode, the viewing angle is 22.5° . The FL-1001 is ideal for such samples as pellets, powders, inks, monolayers, dyes, and various solids.

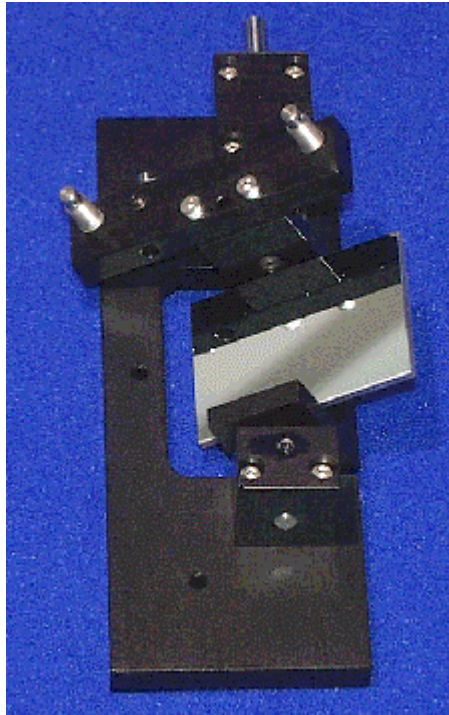

FL-1001 Front-Face Viewing Option.

Gratings

Many gratings are available to replace the standard model in the Fluorolog[®]-3. Rulings with the following specifications are available:

- 300 grooves/mm
- 600 grooves/mm
- 1200 grooves/mm

In addition, a number of different blazes can be purchased:

- 250 nm
- 330 nm
- 500 nm
- 750 nm
- 1000 nm

All gratings are classically ruled, and measure 50 mm × 50 mm. For details and model numbers, contact a Jobin Yvon Inc. Sales Representative.



Grating.

FL-1010 Cut-On Filter Holder

Cut-on filters are used to eliminate second-order effects of the gratings. The single-beam and T-box sampling compartments have three slots that can hold the FL-1010 Filter Holder. Refer to either Model 1939 Cut-On Filter or Model 1938 Cut-On Filter for a detailed description of the placement of the filter holder and the interaction of the cut-on filters and the holder.

FL-1011 Four-Position Thermostatted Cell Holder

The FL-1011 Four-Position Thermostatted Cell Holder keeps a sample at a constant temperature from -20°C to $+80^{\circ}\text{C}$. The temperature is maintained by an ethylene-glycol-water mixture pumped through from an external circulating temperature bath (not included). The holder also includes a magnetic stirrer, for mixing turbid or viscous samples. Also required is the FM-2003 Sample Compartment Accessory.

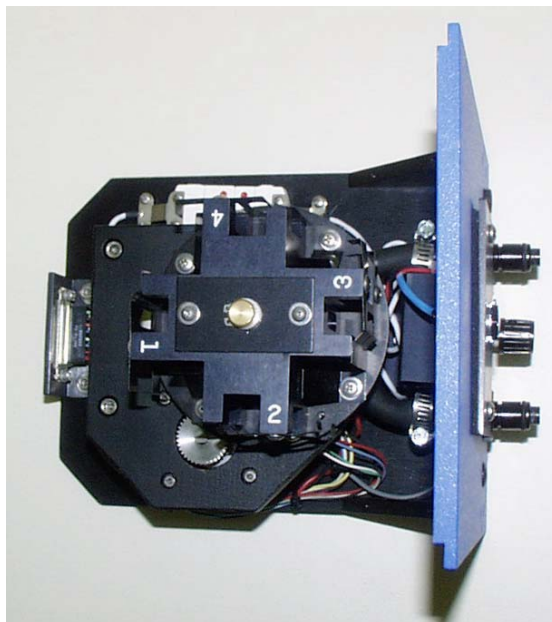

FL-1011 Four-Position Thermostatted Cell Holder.

Installation

- 1 Remove the compartment gap-bed.
- 2 Position the FL-1011 gap-bed drawer.
- 3 Tighten with four screws.
- 4 Attach the $\frac{1}{4}$ " tubing to the brass inlets on the bottom of the holder.



Warning: Failure to clamp these hoses securely may result in flooding and damage to the optics and electronics of the instrument.

Use

- 1 Place the sample in a 10 mm × 10 mm cuvette and insert a magnetic stirring bar.

(The stirring bar is available from Bel-Art Products, Pequannock, NJ)

- 2 Place a cuvette in each holder.



Note: While the four-position model maintains the temperature of all four samples, only one sample is mixed at a time.

- 3 Allow the samples to reach the desired temperature.

- 4 Turn on the magnetic stirrer.

- 5 Select the appropriate mixing speed.

The speed at which the sample should be mixed depends on the viscosity of the sample.



Note: Selecting too high a speed may create a vortex, which could affect the reproducibility of the measurement.

- 6 Run your experiment as usual.

Either right-angle or front-face detection can be used.

- 7 Place the next cuvette in the sample position by lifting up the knob and rotating the holder.

Be sure to press down, to lock the cuvette into the proper position.

FL-1012 Dual-Position Thermostatted Cell Holder

The FL-1012 Dual-Position Thermostatted Cell Holder keeps a sample at a constant temperature from -20°C to $+80^{\circ}\text{C}$. The temperature is maintained by an ethylene-glycol-water mixture pumped through from an external circulating temperature bath (not included). The holder also includes a magnetic stirrer, enabling mixing of turbid or viscous samples. Also required is the FM-2003 Sample Compartment Accessory.

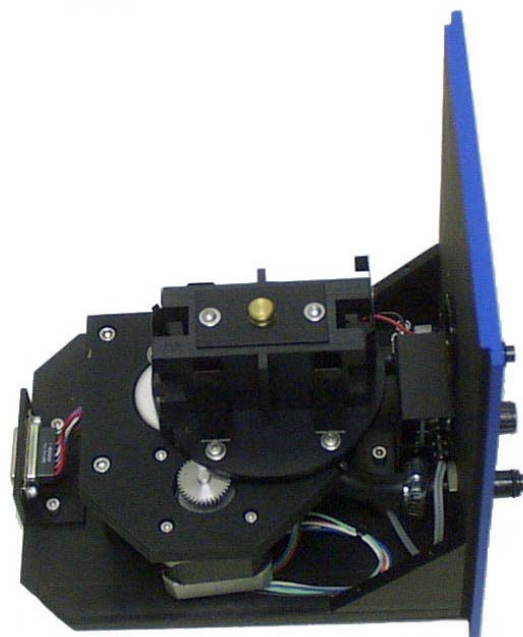

FL-1012 Dual-Position Thermostatted Cell Holder.

Installation

- 1 Remove the present holder from the posts.
- 2 Replace with the FL-1012.
- 3 Tighten the two thumbscrews
- 4 Attach the $\frac{1}{4}$ " tubing to the brass inlets on the bottom of the holder.



Warning: Failure to clamp these hoses securely may result in flooding and damage to the optics and electronics of the instrument.

Use

- 1 Place your sample in a 10 mm × 10 mm cuvette and insert a magnetic stirring bar.

(The stirring bar is available from Bel-Art Products, Pequannock, NJ)

- 2 Place a cuvette in each holder.



Note: While the two-position model maintains the temperature of both samples, only one sample is mixed at a time.

- 3 Allow the sample to reach the desired temperature.

- 4 Turn on the magnetic stirrer.

- 5 Select the appropriate speed.

The speed at which the sample should be mixed depends on the viscosity of the sample.



Note: Selecting too high a speed may create a vortex, which could affect the reproducibility of the measurement.

- 6 Run your experiment as usual.

Either right-angle or front-face detection can be used.

Model 1933 Solid Sample Holder

The Model 1933 Solid Sample Holder is designed for samples such as thin films, powders, pellets, microscope slides, and fibers. The holder consists of a base with graduated dial, upon which a bracket, a spring clip, and a sample block rest.

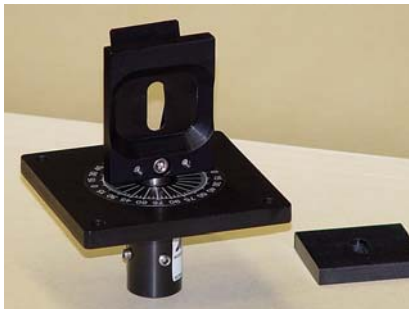

Model 1933 Solid Sample Holder with sample block removed.

Installation

- 1 Remove the present holder.
- 2 Position the base on the posts.
- 3 Tighten the two thumbscrews.

For pellets, crystals, creams, gels, powders, and similar materials:

- 1 Fill the well of the block.
- 2 Place a quartz coverslip or Teflon[®] film over the well.

This holds the sample in place when vertically positioned.

- 3 Carefully insert the block between the bracket and spring clip, so that the sample is perpendicular to the excitation light.



Note: When the sample is perpendicular the light is collected at an angle of 22.5°. This orientation minimizes stray and reflected light off the surface of the sample.

For samples such as thin films, microscope slides, fibers, or other materials:

- 1 Place the material on the block on the side opposite that of the well.
- 2 Insert the block between the bracket and spring clip.

The sample should be perpendicular to the excitation light and fluorescence collected using front-face detection.

- 3 Select front-face detection by turning the knob on the top panel of the sample compartment to FF (front-face).



Note: In the T-box sample compartment, the Model 1692M Selection Mirror is an option. If front-face measurements are to be acquired, this mirror must be installed in the sample compartment.



Note: Before scanning a solid sample, Jobin Yvon Inc. recommends running a water Raman scan in a cuvette with front-face detection. This ensures accurate alignment of the Model 1692M Selection Mirror.

FL-1039 Xenon Lamp Housing

The FL-1039 is the standard lamp housing for the 450-W Xenon Lamp. The power supply is included internally.

FL-1040 Dual Lamp Housing

The FL-1040 Dual Lamp Housing contains both the standard continuous 450-W xenon lamp and a UV xenon flash tube. A swing mirror selects which of the two sources excites the sample. This housing with pulsed lamp is useful for studies of phosphorescence lifetimes and decay analysis. The power supply is internal to the housing.

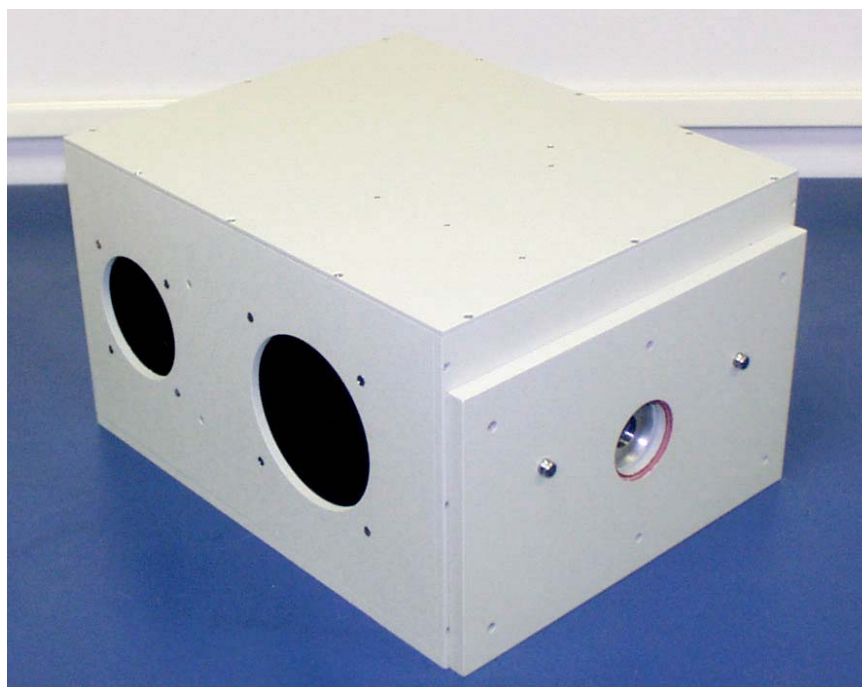

FL-1040 Dual Lamp Housing.

F-3005/6 Autotitration Injector

For controlled, automatic injection of aliquots into the sample of your choice, the F-3005/6 Autotitration Injector is just the thing, available in both 110-V (F-3005) and 220-V (F-3006) models. The F-3005/6 comes with dual syringes, for complete control over dispensing and aspirating volumes of liquids into and out of the sample cell. A mix function is included. With the injector come 18-gauge Teflon[®] tubing and two syringes (1 mL and 250 μ L). The syringes are interchangeable; aliquot size is controllable to 0.1% of total syringe volume.

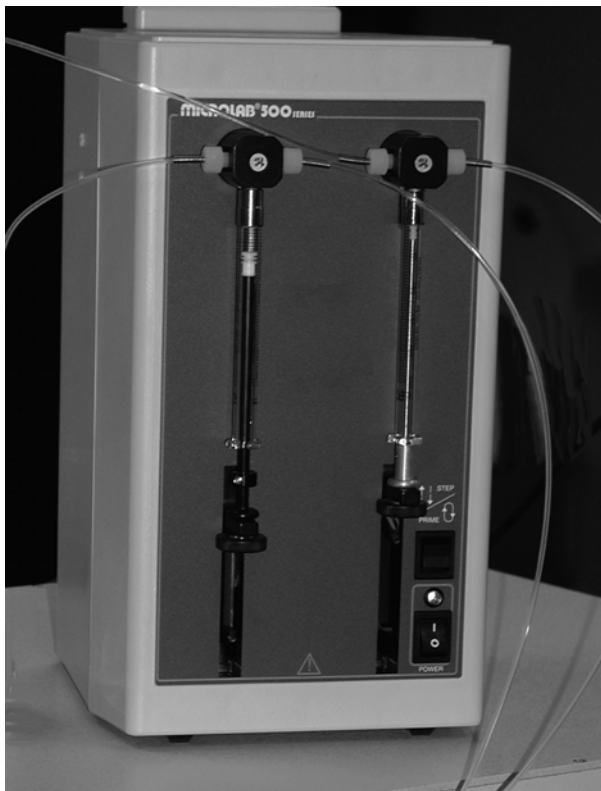

F-3005/6 AutoTitrator Injector.

Models F-3001, F-3002, and F-3003 Microscope Fiber-Optic Interfaces

The Microscope Fiber-Optic Interface eases the use of the Fluorolog[®]-3 systems for fluorescence-microscopy measurements. Interfaces are available for Nikon, Olympus, and Zeiss microscopes.

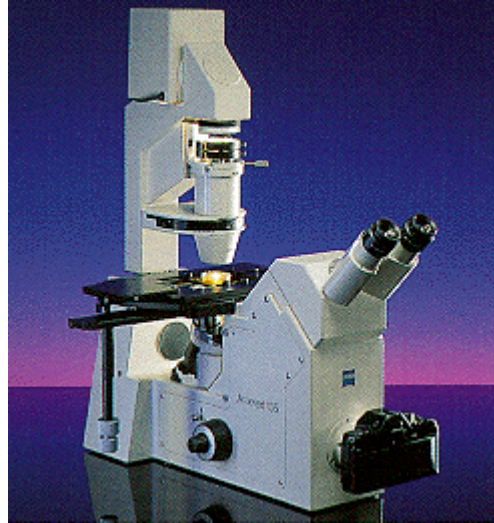

Models F-3001, F-3002, F-3003 Microscope Interfaces

Model 1907 450-W Xenon Lamp

The Model 1907 450-W xenon lamp delivers light from 240 nm to 850 nm for sample excitation. The lamp has an approximate life of 2000 hours, and is ozone-free. The lamp is designed to fit into the FL-1039 Xenon Lamp Housing and the FL-1040 Dual Lamp Housing.



450-W xenon lamp, removed from the protective case.

F-3004 Sample Heater/Cooler Peltier Thermocouple Drive

For rapid control of the sample's temperature in the Fluorolog[®]-3's sample compartment, choose the F-3004 Peltier Drive. Instead of messy fluids, the Peltier device heats and cools the sample thermoelectrically and fast! The temperature range is -10°C to $+120^{\circ}\text{C}$. To prevent condensation of moisture on chilled cuvettes, an injection port for dry nitrogen gas is provided. All software is included, along with a controller and stirring mechanism.

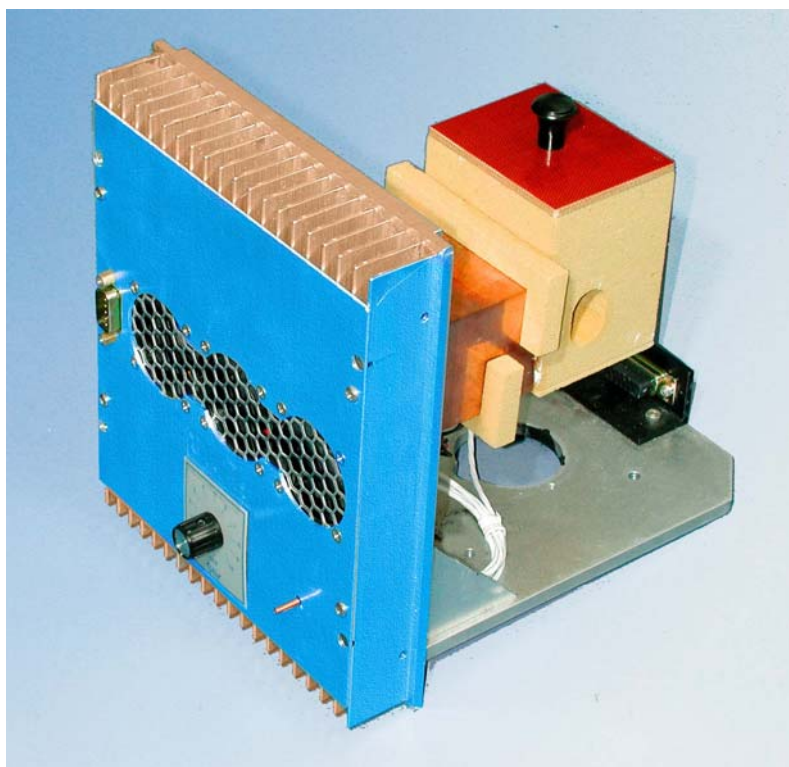

F-3004 Sample Heater/Cooler Peltier Thermocouple Drive.

Phosphorimeter Accessory

The phosphorimeter adds a programmable, pulsed excitation source and selectable signal gating from the signal photomultiplier tube. This provides time-discrimination capability to sort out the lifetimes of simultaneous, competing luminescence emissions. Because the duration of each exciting pulse from the phosphorimeter is very short ($\sim 3 \mu\text{s}$), lamp interference during acquisition of decay curves is minimized. This allows the researcher to follow the decay of samples an order-of-magnitude faster than can be achieved with conventional systems that depend on mechanical choppers.

To run phosphorescence experiments, the FL-1040 dual-lamp housing is required, as well as the FL-1042 phosphorescence upgrade, which adds a controller and electronics. To use the phosphorimeter, turn the external knob on the lamp housing counter-clockwise to Alternate Lamp:

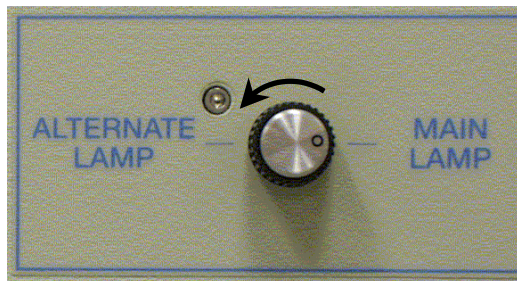

This action rotates a mirror inside, directing light from the flash tube to the sample:

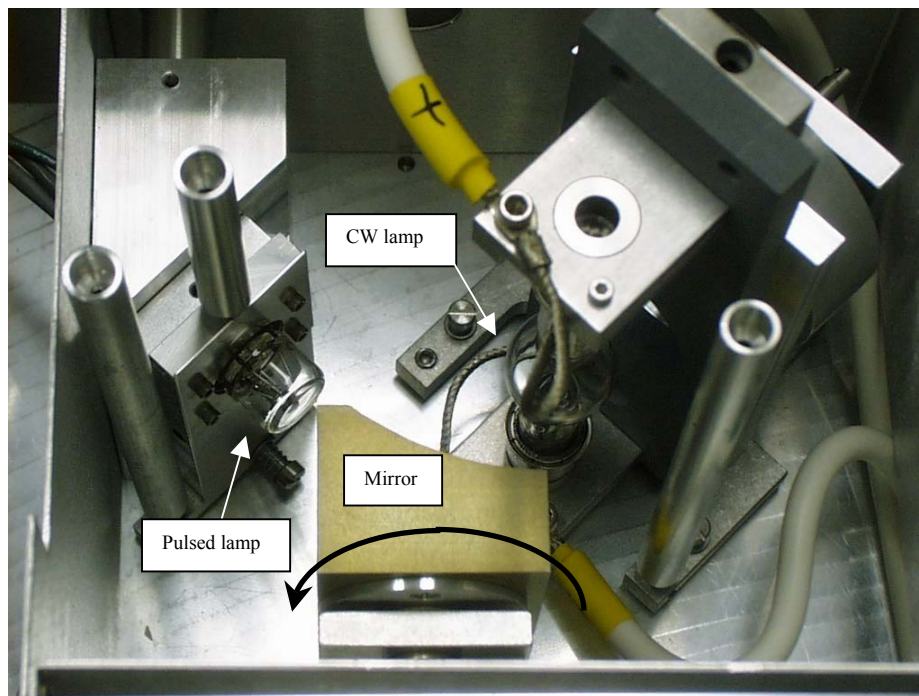

External knob rotates internal mirror.

MicroMax Microwell Plate Reader

The MicroMax Microwell Titer-Plate Reader allows multiple samples to be scanned in one experiment. The MicroMax is controlled through the DataMax software via a serial port to the host computer. The titer plate moves beneath a stationary optical beam, and fluorescence measurements are collected with top-reading geometry. Thus, any titer plates—even disposable ones—may be used. Up to 384-well plates may be inserted into the MicroMax, with a scan speed < 1 min for all plates. Various scan types are possible:

- Single-Point Analysis
- Excitation
- Emission
- Time-Base
- Synchronous
- Multigroup

Signals are transmitted between the Fluorolog[®]-3 and the MicroMax via fiber-optic bundles.



MicroMax Microwell-Plate Reader.

FL-1044 L-Format Polarizer & FL-1045 T-Format Polarizer

For L-format spectrofluorometers, the FL-1044 dual polarizer is ideal. The kit includes two polarizers, to be placed at the entrance and the exit of the T-box. The polarizers are fully automated, and are adjustable to within 1° rotation. Insertion and removal from the optical path is controlled by the computer. For T-format spectroscopy, researchers should order the FL-1045 third polarization unit in addition to the FL-1044.

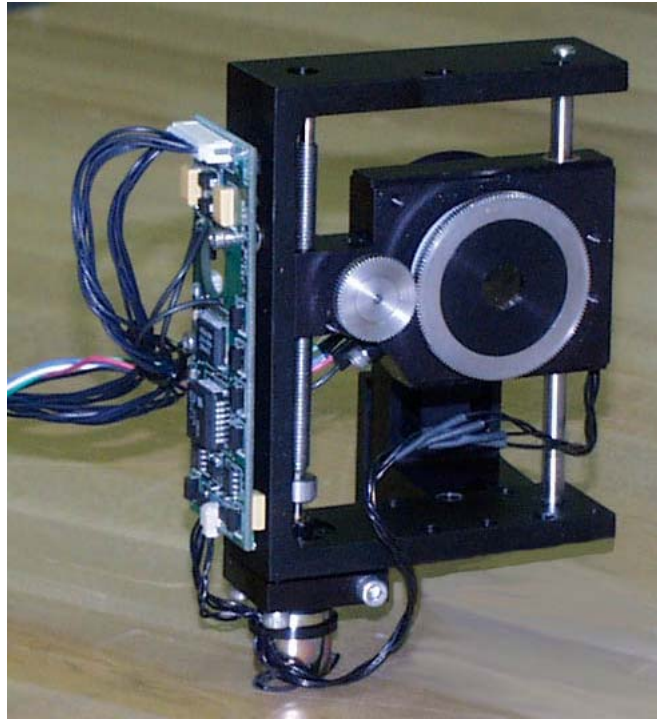

Polarizer.

FL-1015 Injector Port

For the study of reaction kinetics, such as Ca^{2+} measurements, the FL-1015 Injector Port is ideal. This accessory allows additions of small volumes via a syringe or pipette to the sample cell without removing the lid of the sample compartment. With the injector in place, a lock-tight seal is achieved, prevented both light and air from reaching the sample. The Injector Port is recommended for use with the TRIG-15/25 Trigger Box/Event Marker.



FL-1015 Injection Port.

The Injector Port will accommodate most pipettes and syringes, with an injection hole diameter of 0.125" (3.2 mm). A cap is included to cover the port when not in use.

F-1000/1 Temperature Bath

For studies of samples whose properties are temperature-dependent, use the F-1000/1 Temperature Bath. The controller circulates fluids externally, with tubes leading to the sample chamber. The temperature range is from -25°C to $+150^{\circ}\text{C}$. Sensor and all cables are included with the F-1000/1. The Temperature Bath is available in a 110-V (F-1000) and 220-V (F-1001) version.



F-1000/1 Temperature Bath.

Model TRIG-15/25 External Trigger Accessory

The TRIG-15/25 accessory permits the fluorescence system to be operated with almost any external trigger stimulus. Data acquisition can be synchronized with external events, either automatically following a voltage pulse (minimum 3 V above ground), or manually by pushing a button on a trigger-release cable. Multiple trigger events are recorded and stored with the associated data file. A TTL trigger output also is provided, for activating external devices, such as a stopped-flow unit. The front panel has four sets of banana-jack inputs for two independent trigger inputs, Trigger 1 and Trigger 2.



Model TRIG-15/25 External Trigger Accessory.

There are two sets of jacks for each of these two trigger inputs: an upper set, for manual switch inputs, and a lower set, for pulsed voltage inputs. These two input types can be used simultaneously, but any one event is ignored while the interface is activated by another.

7: Troubleshooting

The Fluorolog[®]-3 spectrofluorometer system has been designed to operate reliably and predictably. Should a problem occur, examine the chart below, and try the steps listed on the following pages.

Problem	Possible Cause	Remedy
Light is not reaching the sample.	Excitation shutter closed.	Using the software, open the shutter.
	Slits are not open to the proper width.	Adjust the slits.
	Lamp is not turned on	Turn on lamp by pressing lamp rocker switch, and then the Start button on the xenon-lamp power-supply front panel.
	Monochromator is miscalibrated.	Check and recalibrate monochromator.
	Sample turret is not in correct position.	Using the software, set the position and open the cover to verify the position.
Signal intensity is low.	Lamp is not aligned or focused.	Align and focus the lamp.
	Slits are not open to proper width.	Adjust the slits.
	Shutter(s) is(are) not completely open.	Open the shutter(s).
	Lamp power supply is set to the wrong current rating.	Call the Spex [®] Fluorescence Service Department. (450-W Xe lamp current = 25 A.)
	High voltage is improperly set.	Enter proper voltage: Default HV1 = 950 V
	Polarizer is in the light path.	In Visual Instrument Setup , move the polarizer out of the light path.
	Lamp is too old.	Replace lamp. (450-W lamp has lamp lifetime 1500–2000 h.)
No change in signal intensity.	Shutter(s) closed.	Open all shutters.
	Spectrometers are set to wrong wavelength.	Select appropriate wavelength based on excitation and emission of sample.
	Detectors are saturated	Adjust slits and/or voltages. (Signal detector has linearity to 1.5×10^6 cps when operated in photon-counting mode.)
No signal.	Detectors are saturated.	Reduce slit settings.
	High voltage is off.	Turn on high voltage through the software.
Erratic signal.	Lamp is not on.	Turn on lamp.
	Light leaks.	Check dark value to determine.

[continued on next page]

Communication problems between computer and instrument.	Boot disk corrupted.	Use backup boot disk. If no backup boot disk is available, call Fluorescence Service Department.
	Cables are improperly connected.	Check communications cables' connections.
	Wrong settings for COM ports.	Check <code>datamax\isa_ini\sac.ini</code> file.
Hardware Init. error appears.	Computer I/O controller or SAC I/O controller is failing.	Replace I/O controller: Call Fluorescence Service Department.
	Broken IR sensor in monochromator.	Replace IR sensor: Call Fluorescence Service Department.
Error converting slit units appears.	<code>Datamax\isa_ini\default.set</code> file is corrupt.	Delete <code>datamax\isa_ini\default.set</code> file. When system is restarted, the system will recreate this file.
Sample turret is not operating.	Not turned on.	Verify that the rocker switch on the front panel of the Model 1976 Accessory Controller is in the "1" (On) position.
	Software is not enabled.	Check status.
	Cables are improperly connected.	Check cable connections.
Instrument Control Center icon is not on desktop, but appears in taskbar	<code>isamain.ini</code> is improperly set	In the windows directory, open <code>isamain.ini</code> Change the coordinates listed to Left = 524 Top = 174 Right = 824 Bottom = 282 If problem persists, change <code>isamain.ini</code> 's properties into a read-only file.
	<code>isascan.set</code> or <code>isascan.vw</code> are corrupted	Delete <code>isascan.set</code> and <code>isascan.vw</code> from <code>datamax</code> directory. (They will be recreated automatically.)

Using diagnostic spectra

Often the spectrum reveals information regarding the hardware or software parameters that should be adjusted. The following spectra occur with explanations regarding problems leading to their appearance.



Note: Not all spectra shown in this section were produced using the Fluorolog[®]-3. The spectra are presented to show different possible system or sample problems, and may not reflect the superior performance of the Fluorolog[®]-3.

Lamp scan

Running a lamp scan verifies system integrity and indicates whether the correct parameters for the best possible trace are being used. The following spectrum shows the trace resulting from a lamp scan run with a known good lamp.

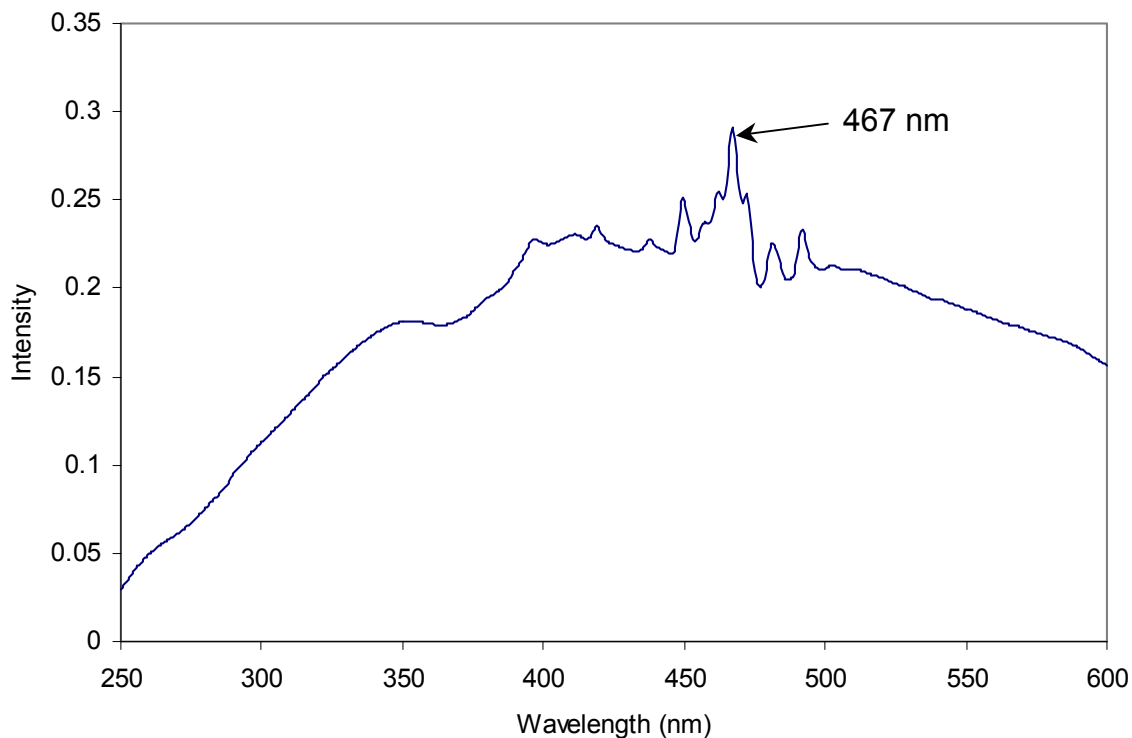

Scan of good quality 450-W xenon lamp in Fluorolog-3 with single excitation monochromator.

The following lamp scan spectrum shows poor resolution in the area around the peak.

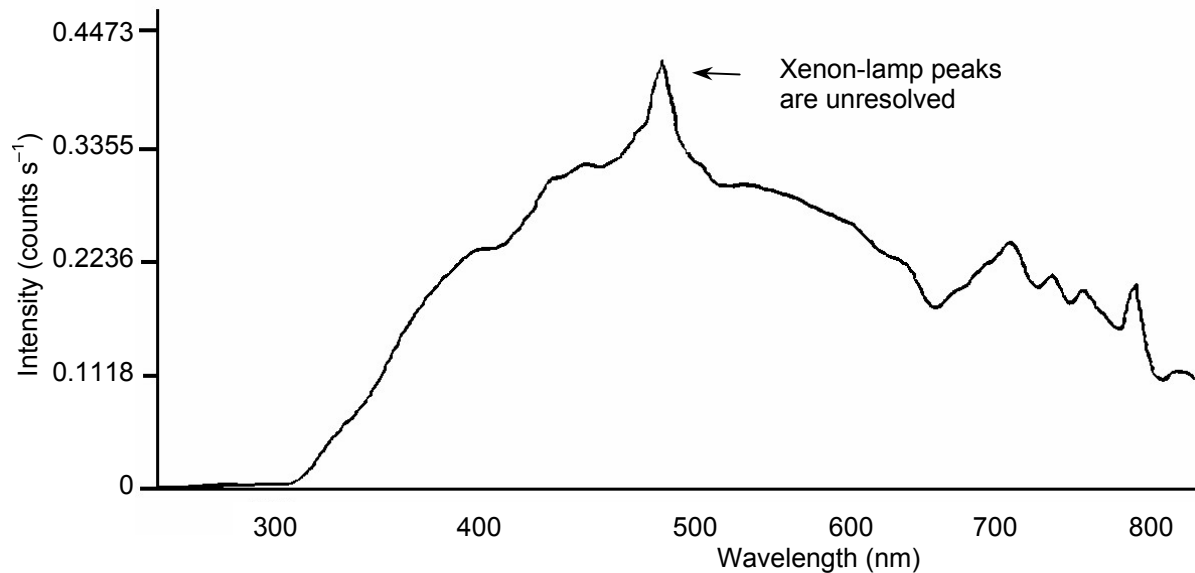

Lamp scan of 150-W Xe lamp. Note poor resolution in the area near the 467-nm peak.

This lack of spectral resolution appears because the slit widths are set too wide. To resolve this problem, narrow the slit widths.

Water Raman spectra

Contaminated water

Running a water Raman scan helps identify abnormalities as a result of accessory problems or miscalibration. The following spectrum is normal:

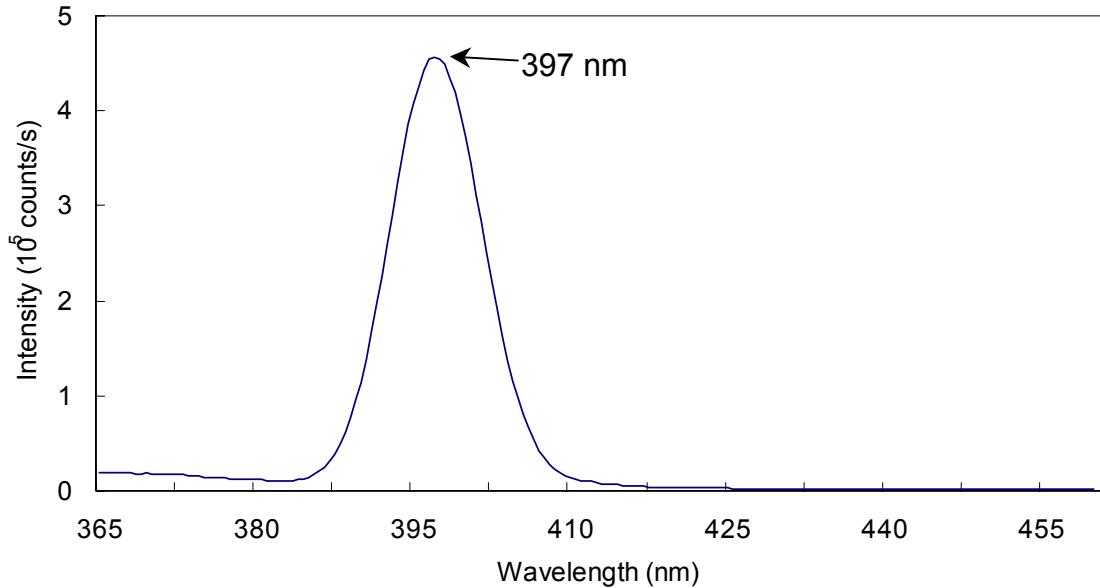

Clean water Raman scan.

Below is a normal water Raman spectrum superimposed on one that exhibits a problem. In this instance, the water was contaminated, resulting in a high background.

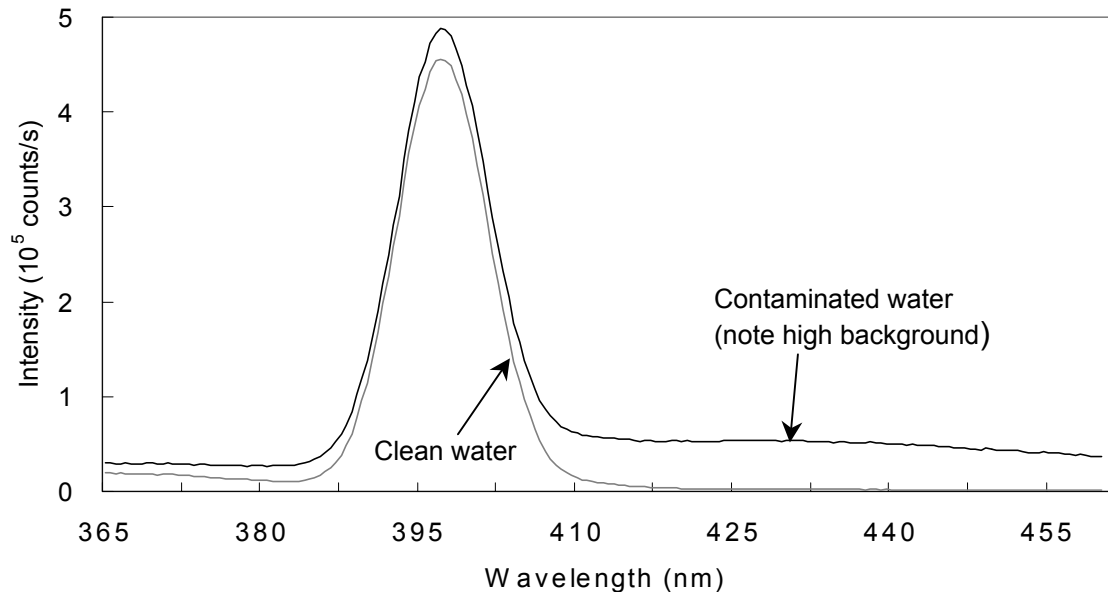

Contaminated water in a water Raman scan.

If a spectrum similar to this is obtained after running a water Raman scan,

- 1 Rotate the cuvette 90° and rerun the scan.

If the problem goes away, then the problem was due to the cuvette surface. Clean or use a different cuvette.

Or

- 1 Clean the cuvette.
- 2 Fill with fresh, double-distilled, deionized water.

If the problem goes away, then the problem was due to contaminated water.

Light not striking cuvette

The following graph shows a normal water-Raman scan with a superimposed problem scan.

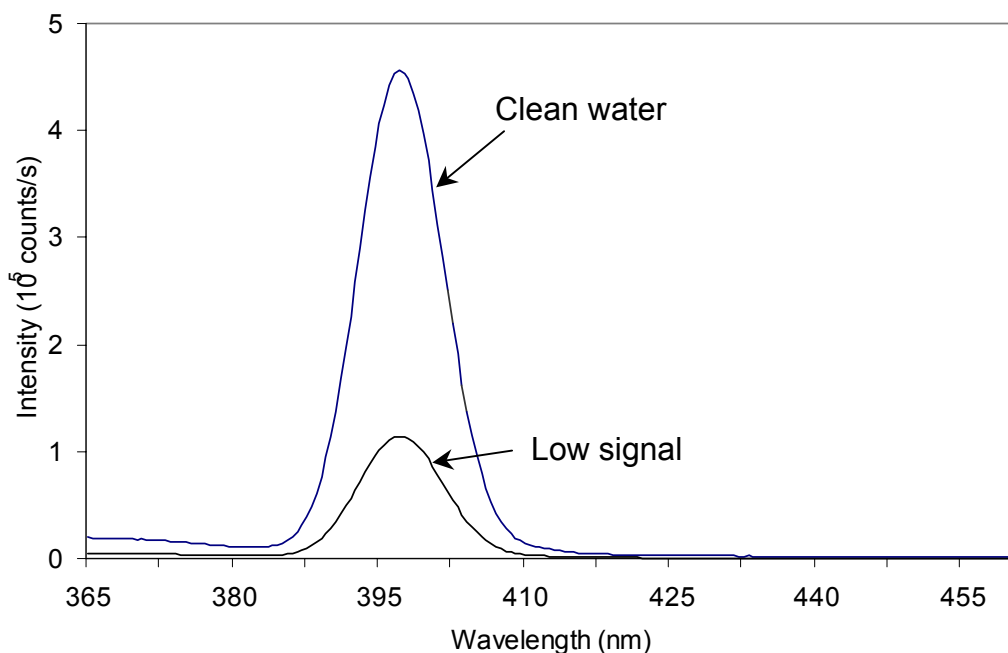

Low intensity during a Raman scan.

Here the problem is low intensity of the water signal when compared with the superimposed typical water Raman scan. To resolve this problem:

- 1 Make sure the cuvette is filled to the proper level.

Light should fall on the sample, and the meniscus should not be in the light path.

- 2 Make sure that the excitation and emission slits are set to the proper widths.
- 3 Verify that the detector is set to the proper voltage.

Stray light

In the following diagram, notice the high level of stray-light below 380 nm in the water Raman spectrum.

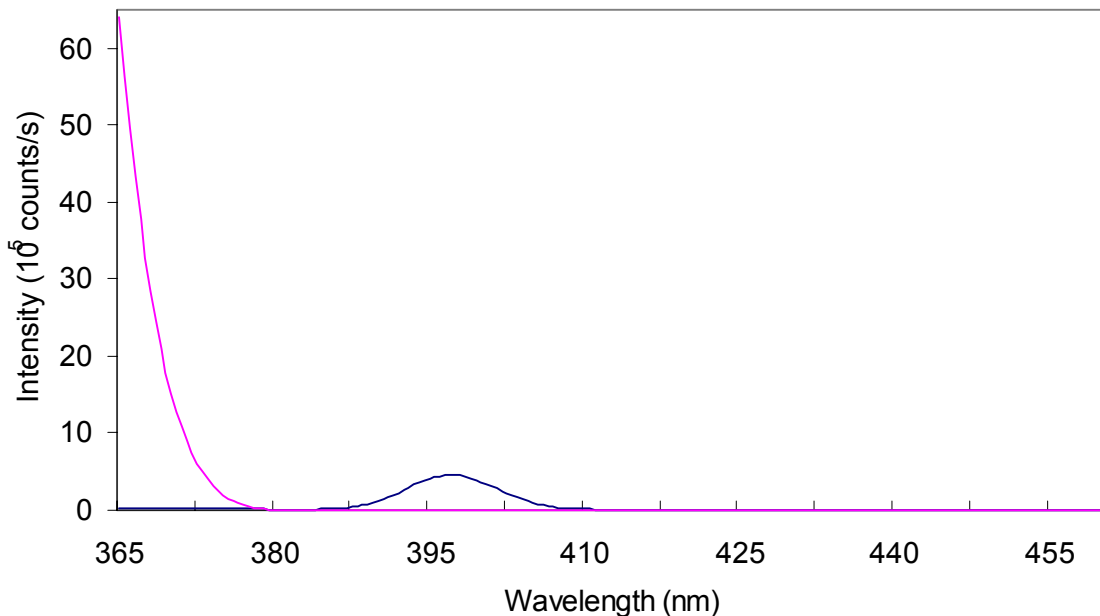

High stray light in a water Raman scan.

To correct this problem,

- 1 Inspect the cuvette surface for fingerprints and scratches.
- 2 Clean the cuvette or use a new one.
- 3 Verify that the excitation and emission slits are set correctly for a water Raman scan.
- 4 Verify that the excitation spectrometer is at the correct position.

Further assistance...

Read all software and accessory manuals before contacting the Spex® Fluorescence Service Department. Often the manuals show the problem's cause and a method of solution. Technical support is available for both hardware and software troubleshooting. Before contacting the service department, however, complete the following steps.

- 1 If this is the first time the problem has occurred, try turning off the system and accessories. After a cool-down period, turn everything back on.
- 2 Make sure all accessories are properly configured, and turned on as needed.
- 3 Following the instructions in Chapter 3, *System Operation*, run a lamp scan and a water Raman scan to make sure the system is properly calibrated. Print the spectrum for each and note the peak intensities.
- 4 Check this chapter to see if the problem is discussed.
- 5 Visit our web site at www.isainc.com/fluor/fluor.htm to see if the question is addressed in the **Systems** or **FAQs** sections of the site.
- 6 Try to duplicate the problem and write down the steps required to do so. The service engineers will try to do the same with a test system. Depending on the the problem, a service visit may not be required.
- 7 If an error dialog box appears in DataMax, write down the exact error displayed.
- 8 In DataMax, in the **Instrument Control Center** toolbar, choose **Help**. Under **Help**, choose **About Instrument Control Center**. This opens the **About Instrument Control Center** window. The version of the software is listed here.

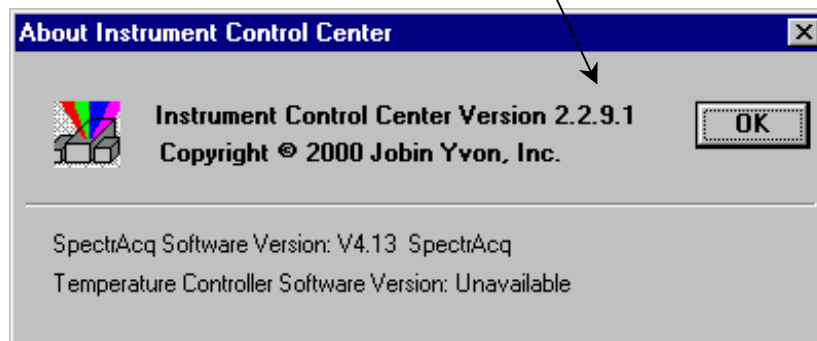

- 9 In Run Experiment toolbar, open the **About DataMax** window. Make a note of the software's and instrument's serial numbers, and instrument configuration, including all accessories.

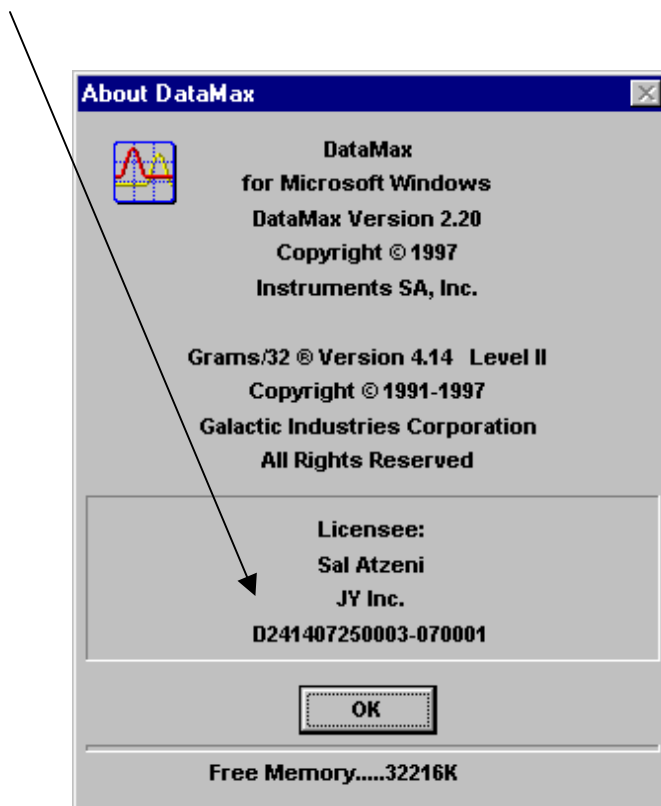

If the problem persists or is unlisted, call the Spex[®] Fluorescence Service Department at (732) 494-8660 × 160.

8: Introduction to Lifetime Measurements

Introduction

Although the Fluorolog[®]-3 spectroscopy system is fully capable of performing lifetime measurements, it was designed to excel in the area of fluorescence measurements. Operating within a lifetime range of 10 ps to 10 μ s and a frequency range of 0.2 to 310 MHz, the Fluorolog[®]-Tau-3 specifically addresses the needs of phosphorescence measurements.

To design and build the Fluorolog[®]-Tau-3, Jobin Yvon Inc. started with the proven performance of a Fluorolog[®]-3, the most sensitive, steady-state spectrofluorometer in the world, and added unique optical and electronic components for frequency-domain measurements. From picoseconds to microseconds, the Fluorolog[®]-Tau-3 performs reliably and delivers reproducible results time after time.

The proven sensitivity and resolving power of the Fluorolog[®]-3 and the high-quality Jobin-Yvon-Inc. optics provide the precise collimation to take maximum advantage of the system's CW source, thereby ensuring accurate results. In addition, software is equipped with a user-friendly interface, intuitive commands, a powerful post-acquisition module, and comprehensive on-line help.

DataMax, the software included with the Fluorolog[®]-Tau-3, allows you to acquire steady-state as well as lifetime measurements. DataMax controls the spectrometers, programmable excitation shutter, automated four-position sample changer, slits, and high voltage to the signal and reference detectors. The software acquires, processes, and manages data.

The lifetime application is integrated seamlessly into the steady-state software. Researchers who upgrade a Fluorolog[®]-3 to a Fluorolog[®]-Tau-3 will find the DataMax lifetime software easy to use. Researchers using a Fluorolog[®]-Tau-3 instrument for the first time will likewise find it easy to use.

Lifetime measurements

The lifetime software is based on acquisition of frequency-domain lifetime measurements. In this technique, the excitation light is sinusoidally modulated. The emission from the sample is a forced response to the excitation, and therefore is modulated at the same frequency as the excitation light. The excited state has a finite lifetime. This means that the modulated emission relative to the excitation is offset by a phase angle, ϕ , and is demodulated. The following figure shows various parameters used within the frequency domain for lifetime measurements.

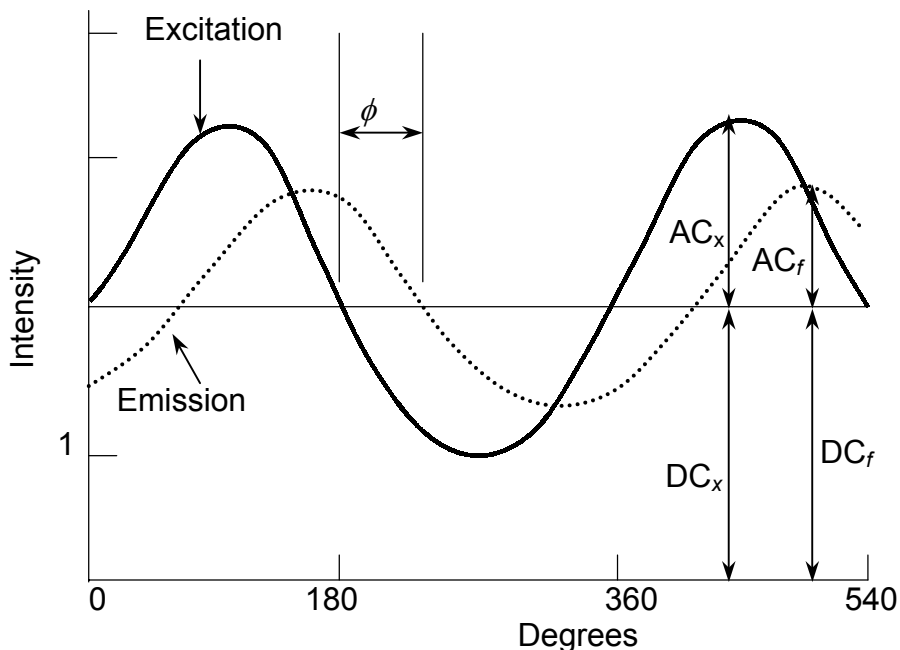

Parameters used in frequency-domain measurements.

The figure shown above illustrates a sinusoidal excitation with a circular frequency, ω , an amplitude, AC_x , and offset by a DC voltage, DC_x . The sample responds with an identical circular frequency, ω , damped amplitude, AC_f , and offset by a DC voltage, DC_f . In a fluorescence-lifetime measurement, the phase angle, ϕ , and demodulation factor, m , are measured at each frequency and used to calculate the phase lifetime (τ_p) and modulation lifetime (τ_m). The above figure shows that the relative amplitude of the emission (AC_f/DC_f) is smaller than that of the excitation (AC_x/DC_x). The demodulation factor, m , is AC_f/DC_f divided by AC_x/DC_x .

The equations used to calculate the phase (τ_p) and modulation (τ_m) of lifetime measurements are:

$$\tan \phi = \omega \tau_p$$

$$\tau_p = \omega^{-1} \tan \phi$$

$$m = (1 + \omega^2 \tau_m^2)^{-1/2} = \frac{AC_f / DC_f}{AC_x / DC_x}$$

$$\tau_m = \omega^{-1} \left(\frac{1}{m^2} - 1 \right)^{1/2}$$

Types of lifetime scans

The type of scan defines which measurement will be acquired. In lifetime operation, four scan types are available:

- Lifetime
- Lifetime-resolved
- Dynamic depolarization
- Time-resolved.

Recalling an experiment allows the user to retrieve the experimental parameters. Each scan type is defined below.

Lifetime acquisition

The *lifetime acquisition* type of scan determines accurate lifetimes from simple single-component systems as well as complex heterogeneous systems. The measurement records the phase shift and modulation at specified frequencies for an unknown sample relative to a reference standard.

Lifetime-resolved acquisition

A *lifetime-resolved acquisition* scan resolves up to three components of overlapping spectra based on differences in the fluorescence lifetimes. More complex systems can result in improved resolution of one or more spectra but complete resolution requires additional manipulation of data acquisition parameters such as excitation wavelength. An application using lifetime-resolved-acquisition scans can spectrally resolve tyrosine and tryptophan emission spectra from a protein containing both residues. To improve resolution, simply measure the lifetime and obtain the spectral characteristics of the individual components prior to conducting a lifetime-resolved acquisition scan. Generally, this technique works best if a factor of at least 1.5 exists between the lifetimes being resolved spectrally.

Anisotropy-decay acquisition

An *anisotropy-decay acquisition* experiment choice allows the study of rotational properties of fluorescent molecules and probes. As the fluorophore rotates, a change in the polarization occurs. Monitoring this change provides information about the excited state properties of the sample. The anisotropy is affected by Brownian rotation, energy transfer, re-absorption, re-emission and light scattering. Applications involve studying asymmetric complex molecules, environmental perturbations, binding, hindered-rotation phase transitions, and internal viscosities of bilayers.

Time-resolved acquisition

Time-resolved acquisition scans measure the change in the spectral characteristics of the sample during the lifetime of the excited state. The measurement consists of determining the frequency response of the sample over a specified emission range. Applications involve solvent relaxation of the excited state and excimer formation.

9: Xenon Lamp Information & Record of Use Form

Xenon lamps typically are used in fluorescence instruments because they provide a continuous output from 240 nm to 600 nm. In the Fluorolog[®]-3 spectrofluorometers, the standard xenon lamp is ozone-free. The xenon-lamp spectrum exhibits a characteristic peak around 467 nm, which can be used to indicate whether the excitation spectrometer is properly calibrated.

As the xenon lamp ages, water Raman spectra have a progressively lower peak intensity. During its lifetime, the lamp stabilizes at approximately 60% of its original intensity. Keep a record of the time the lamp is in use on the form provided on the following page. From this record, you will be able to determine when the lamp is near the end of its lifetime. The maximum lifetime of the 450-W lamp is 2000 hours.

10: Applications

Introduction

The Fluorolog[®] series of spectrofluorometers have earned the reputation for being the most sensitive in the world. Because the Fluorolog[®]-3 provides superior optical and electronic components combined with a comprehensive selection of accessories, it provides the highest sensitivity and selectivity for all types of samples.

Jobin Yvon Inc. realizes the importance of accurate and reproducible data. Therefore, the systems are calibrated and tested prior to shipment to a customer site and then again after installation. Performance spectra indicate the operational parameters and ensure that the system is operating within specifications. Fluorolog[®]-3 systems employ the most sophisticated data-correction techniques to yield accurate and reproducible fluorescence spectra.

For example, fluorescence emission spectra are affected by the response characteristics of the spectrometer and optical components such as gratings and detectors. To compensate for these responses, radiometric correction factors are individually determined for each Fluorolog[®]-3 system and are supplied with the DataMax software. The user can update these correction factors periodically if necessary. Simple point-and-click operations or user-controllable default system parameters allow real-time or post-processing correction of spectral data.

To correct for variations in the intensity of the excitation source, Fluorolog[®]-3 spectrofluorometers also monitor the excitation beam with a wavelength-independent reference detector. The raw emission data can then be automatically ratioed to intensity information generated by the reference detector. The effect of this correction can be seen in the upper plot on the next page.

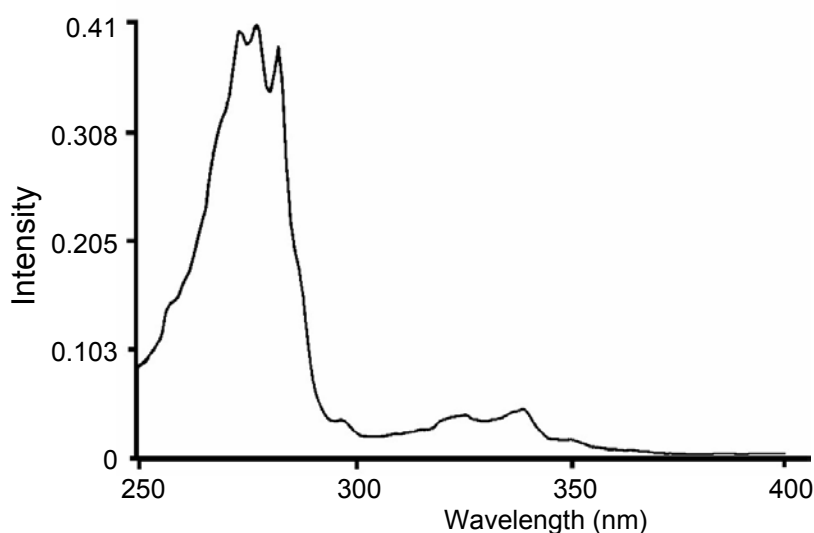
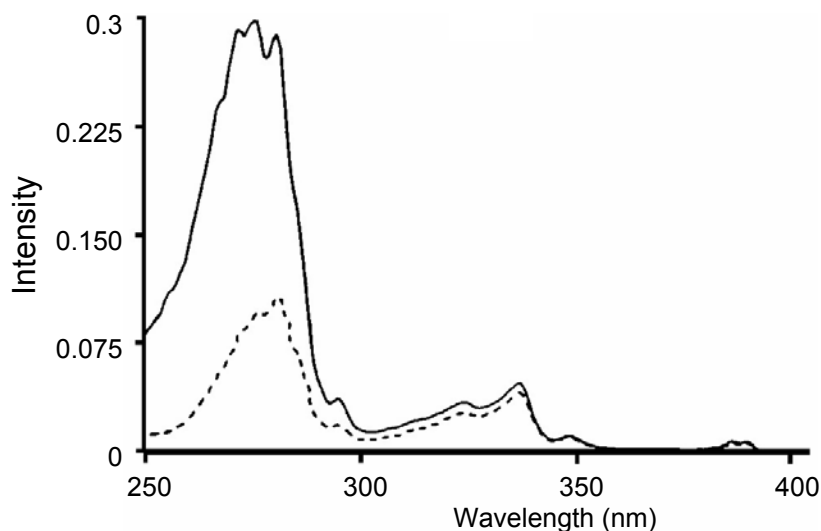

Spectra of azulene. Upper plot: corrected (solid line) and uncorrected (broken line) excitation spectra. Lower plot: an absorption spectrum.

The broken line in the upper plot traces the uncorrected excitation spectrum of an azulene sample acquired on a Fluorolog[®] system without reference-detector ratioing. The solid line represents the same spectrum automatically corrected for the wavelength-dependence of excitation-source intensity. The lower plot shows the absorption spectrum of azulene, acquired on the same spectrofluorometer system. The corrected excitation spectrum shows strong similarity and fine structure compared with the corresponding absorption spectrum.

The Fluorolog[®] series of spectrofluorometers have carved a niche in the scientific community by consistently demonstrating the capability to perform extraordinary tasks. Some of the remarkable features of the system are outlined below.

Detecting sub-picomolar concentrations of fluorescein

Instrument sensitivity is often expressed in terms of the *limit of detection* of a standard substance. The superior sensitivity of Fluorolog[®]-3 systems is demonstrated by their ability to detect sub-picomolar concentrations of standard substances such as fluorescein. Often, other instruments perform this task by extrapolating from much higher concentrations. The Fluorolog[®]-3, however, not only detects femtomolar concentrations of fluorescein, but directly measures the true emission spectrum of 50-femtomolar fluorescein using an integration of only 1 second—a clear demonstration of superior performance.

Reduced-volume samples

Because the samples required to produce spectral data may be expensive or obtained only in limited quantities, the precise imaging quality and photon-counting sensitivity of the Fluorolog[®]-3 spectrofluorometers are invaluable assets. The following diagram compares the fluorescence emission of 20-nM resorufin acquired using the 20- μ L and 4-mL cells. Notice that the signal level is maintained with either cell.

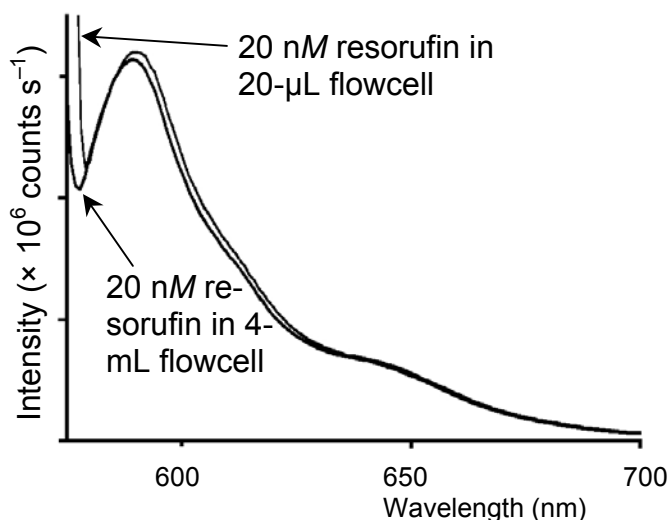

Comparison of the fluorescence emissions of 20-nM resorufin using a 20- μ L cell and a 4-mL cell.

Fluorescence detection of highly scattering samples

Qualitative and quantitative determinations normally are difficult to ascertain from highly scattering samples. Typically, fluorescence signals are dwarfed by stray or scattered light from the sample. The flexibility of the Fluorolog[®]-3 systems, however, allows the introduction of a double-grating emission spectrometer, thereby improving the system's stray-light rejection. With a single-grating emission spectrometer, scattered light from the sample often finds its way through the exit along with the selected band of emitted light. However, when the band is re-dispersed by the double-grating spectrometer, most stray light is stripped away as the band passes through the exit slit to the emission detector.

Quantum-yield calculations

Among the many features unique to Fluorolog[®]-3 systems, is the capacity to measure fluorescence-related parameters required to calculate the quantum yield for samples in solution. This includes recording excitation-source intensity and calculating the area under the corrected emission spectra.

Characterizing complex mixtures via synchronous scanning

The fluorescence spectrum of a complex mixture often contains overlapping spectral features representative of the mixture and revealing no indications of the contents of the sample. A spectrum of this nature is all but useless. *Synchronous scanning* offers a solution to this problem.

Simultaneous scanning of the excitation and emission spectrometers with a constant offset between them yields an intensity proportional to the product of the emission and excitation intensities. This resulting spectrum often can be analyzed readily.

The figure below shows the emission scan and the synchronous scan of a mixture of polynuclear aromatic hydrocarbons.

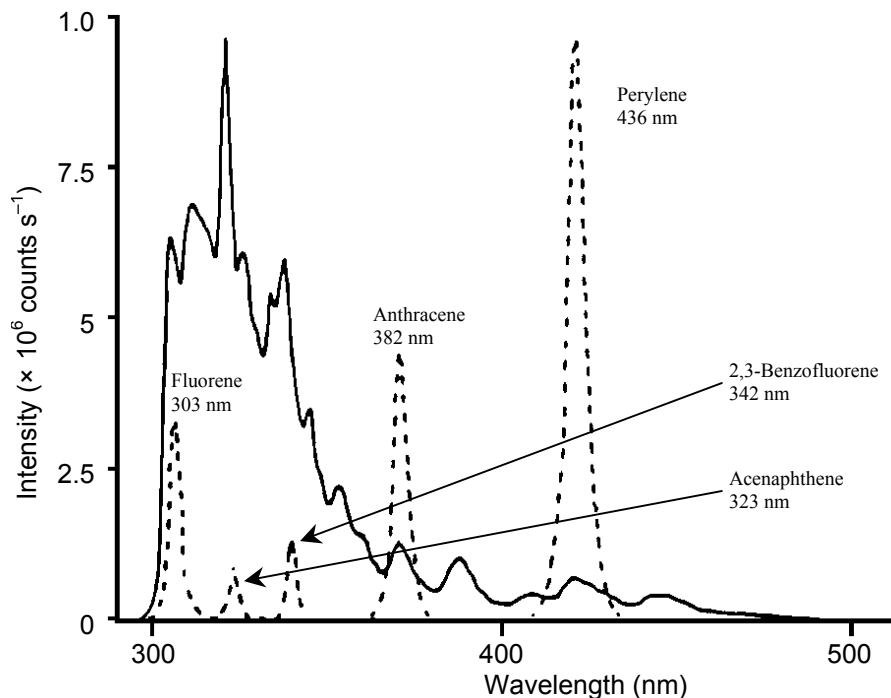

Emission (solid line) and synchronous (broken line) scans of a mixture of polynuclear aromatic hydrocarbons.

The solid line in the figure above is the emission spectrum acquired on a Fluorolog[®] system (single-grating monochromators) with constant wavelength excitation. As shown by the broken line, when the sample is scanned synchronously, five individual components are resolved into unique, sharp peaks indicative of the individual compounds.

Operating in the IR region

The Fluorolog[®]-3 series of spectrofluorometers can be equipped to operate in the infrared region of the spectrum, thereby opening up totally new areas of applications for fluorescence spectroscopy. Typically, an IR spectrofluorometer requires components significantly different from those found in conventional instruments. Because the most widely used photomultiplier detector is insensitive above 860 nm, an IR spectrofluorometer must be equipped with a red-sensitive photomultiplier, or a solid-state detector whose response is effective far into the IR region. With a photomultiplier sensitive to 1 μm , only minimal system modification is necessary. A phase-sensitive lock-in amplifier and a light chopper are required.

Phosphorescence for time-resolved data

Both fluorescence and phosphorescence spectra are photon emissions that occur when molecules return from an excited electronic state to the ground state. The nature of the excited state distinguishes the two: fluorescence is associated with relaxation from a singlet excited state, while phosphorescence is associated with relaxation from a triplet excited state. Fluorescence usually occurs within a few nanoseconds after excitation.

Because triplet transitions are “forbidden” quantum-mechanically, the average phosphorescence decay times are generally longer, ranging from a few microseconds to several seconds. Thus, phosphorescence offers a longer observation period for monitoring reactions, looking at environmental effects on a sample, or following changes in the hydrodynamic characteristics of macromolecular systems.

In phosphorescence experiments using the Fluorolog[®]-3 and the FL-1042 Phosphorimeter Assembly, the sample is excited by a pulsed light source. Acquisition of the emission signal is synchronized to the pulse, with user-specified delay and sampling times, to produce time-resolved spectral data. With an appropriate choice of delay time, the user may select only the luminescence of interest.

Time-resolved data-acquisition also makes it possible to acquire phosphorescence decay curves and compute lifetimes of lanthanides such as europium and terbium, as well as the biological probe eosin.

Low-temperature scans

One way to protect a sample from molecular collisions that can quench luminescence is by isolating the sample in a rigid matrix. Thus, cooling with liquid nitrogen enhances the phenomenon of fluorescence, even for seemingly dormant samples. In addition, the superior resolution of a Fluorolog[®]-3 double-grating spectrometer system optimizes measurements under these conditions.

Monitoring kinetic reactions using time-based fluorescence

By setting the wavelengths at the excitation and emission peaks of a sample, the Fluorolog[®]-3 systems can monitor fluorescence as a function of time. This permits the use of Fluorolog[®]-3 systems in reaction-rate determinations, which monitor the formation or breakdown of a fluorescing species. Reaction-rate determinations are highly selective. Because only *changes* in intensity are considered, the method is not affected by interference from continuous background signals or steady-state scatter.

Front-face detection to enhance data collection for absorbent or solid samples

Fluorescence typically is collected at right angles (90°) from transmitted or scattered light. Yet right-angle viewing is inappropriate for some samples. Imprinted paper, for example, reflects light, which interferes with accurate data collection. In highly absorbent samples like hemoglobin or milk, most of the emitted light is reabsorbed before the fluorescence can be measured. A significant design feature of the Fluorolog[®]-3 Single-Beam and T-Box spectrofluorometers is that they offer a choice between conventional right-angle or front-face fluorescence detection. Front-face viewing is ideal for solid, turbid or highly absorbent samples such as pellets, powders, and monolayers on

microscope slides. A swing-away mirror is positioned to allow collection of sample luminescence at 90° to the excitation beam, or front-face at 22.5°. In front-face viewing, the fluorescence is collected from the sample's surface.

Polarization to detect trace quantities of biological probes

Used in conjunction with the large number of fluorescent dyes suitable for biological research, fluorescence spectroscopy has greatly expanded our understanding of metabolic processes on the molecular level. The Fluorolog[®]-3 design offers unparalleled sensitivity for such work.

Fluorescence polarization offers a safe, sensitive immunoassay technique—fluoroimmunoassay (FIA). This method has none of the licensing and waste-disposal problems associated with radioimmunoassay (RIA). Immunoassay methods, which are based on competitive antibody-binding reactions, require the ability to distinguish between bound and unbound species. This selectivity is inherent in fluorescence polarization techniques.

In fluorescence polarization, the excitation beam is passed through a polarizing prism, and the emitted luminescence is analyzed with another polarizer alternately oriented parallel and perpendicular to the excitation polarization. The measured polarization depends on the rotation of the molecules between absorption and emission. Because the measurement reflects changes in rotation, polarization can be used to distinguish between free molecules and the larger, slower antibody-bound molecules in immunoassays. The use of polarizer prisms instead of film polarizers ensures that the researcher is guaranteed full spectral coverage from the ultraviolet to the visible. Over time, film polarizers tend to become photobleached, especially if exposed to UV light.

The applications for the Fluorolog[®]-3 spectrofluorometers are almost endless. By simply changing accessories, adding or removing a hardware component, or accessing the proper software controls, the user can ensure that the system continues to grow or change as application needs change. The modular construction and interchangeable accessories make the Fluorolog[®]-3 even more attractive to most industries.

11: Producing Correction Factors

Introduction

Collecting accurate information about the fluorescent or phosphorescent properties of a sample depends upon several factors: equipment, sample, and timing. To ensure that the spectra are indicative of the actual sample properties and not of external conditions, data often must be corrected. To *correct* data means to remove information from the data not directly related to the properties of the sample. Specifically, several items that may appear mixed into a spectrum are:

- Fluctuations caused by the light source.
- Influence of the sample holder.
- System features.

Corrections are made for each of these potential problems by using radiometric correction factors, running a blank scan (which is then subtracted from the sample scan), and using the software's **Auto Zero** function (which closes the programmable excitation shutter, records the background dark counts for 10 s, and automatically subtracts this value from the data as they are acquired). **Blank** and **Auto Zero** functions are described in the system's software manual.

Gratings, detectors and other spectrometer components have response characteristics that are functions of wavelength. These characteristics are superimposed on spectra, and may yield a potentially misleading trace. For accurate intensity comparisons, such as those required for quantum-yield determinations, spectrometer-response characteristics must be eliminated.

Supplied with your instrument are sets of excitation and emission correction factors designed to eliminate response characteristics. These files¹, `xcorrect` and `mcorrect`, are included with the software and should be copied to the hard disk. These files must be in the same directory as the data to be corrected. The excitation correction range is from 220–600 nm, and the correction range for emission spectra is from 300–850 nm.

Instructions for use of correction factors are in Chapter 4. This chapter only describes the steps for *generating* correction factors. Perform this procedure *only* when the gratings or detectors have been replaced with those of different specifications than the original hardware.

¹ Filenames include a three-letter extension. For the sake of clarity, the extensions are omitted in this manual. Refer to the software manual for specifics regarding extensions.

Generating emission correction factors

Required kits

Emission correction factors should be updated periodically or whenever different gratings or signal detectors are installed. The correction factors can be updated either at the user's location, or by a representative from the Spex[®] Fluorescence Service Department. To arrange for a visit and a fee estimate, call our service department. To update the correction factors without a service visit, follow the instructions below.

One way to generate correction factors for your instrument is to scan the spectrum of a standard lamp. Because the actual irradiance values of the standard lamp as a function of wavelength are known, dividing the irradiance values by the lamp spectrum results in a set of relative correction values. These values can then be applied to the raw fluorescence data. The emission correction factor file `mcorrect` was acquired in this manner.

To generate emission correction factors, several items are needed: a standard lamp, appropriate holders, and a scatter assembly. Jobin Yvon Inc. offers two kits: the Model 1908 Standard Lamp Accessory, and the Model 1908MOD Scatter Assembly. The Model 1908 is a complete correction factor kit, while the Model 1908MOD Scatter Assembly is provided for users who already have a calibrated standard lamp and a constant-current source.

The Model 1908 Standard Lamp Assembly is a complete correction factor kit, which includes the following items:

- 200-watt quartz tungsten-halogen filament lamp with irradiance values
- Constant Current Power Supply with lamp holder
- 1908MOD Scatter Assembly

- The Model 1908MOD Scatter Assembly includes:
 - Lamp Mount Assembly and Mask with Square Center
 - Scatter Block with neutral-density filter and reflectance plate

Generation

- 1 Open the **Real Time Display**.
- 2 Turn off the high voltage to the emission photomultiplier tube.
- 3 Close the slits.
- 4 Place the 1908MOD Scatter Block Assembly in the

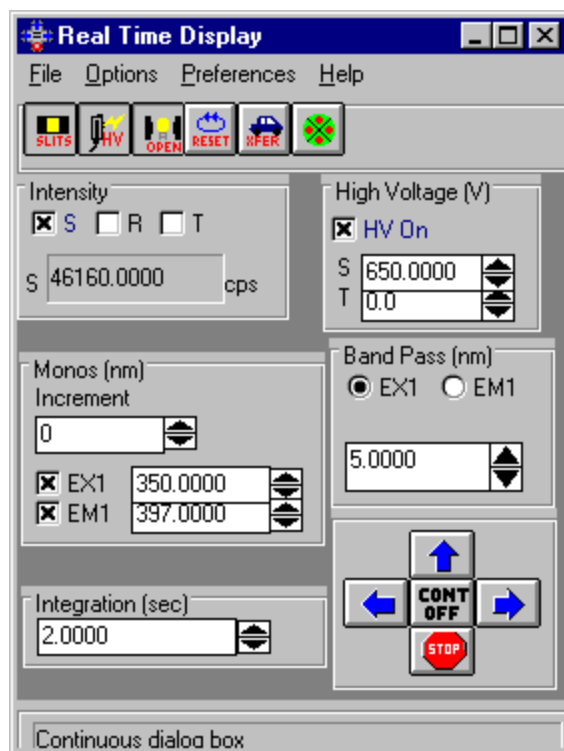

sample chamber, so that light is directed toward the right angle.

Looking down, the scatter plate should be toward the left.

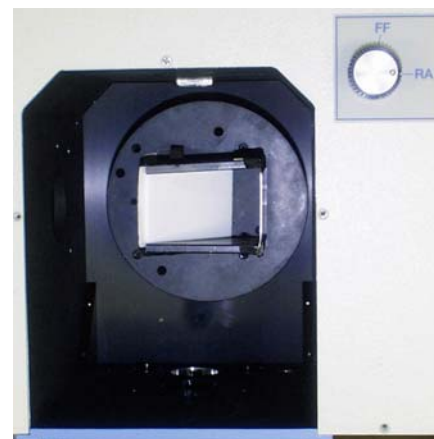

- 5 Place the mask over the sample compartment.

The square hole should be vertically centered over the white scatter plate. Secure the mask with black tape.

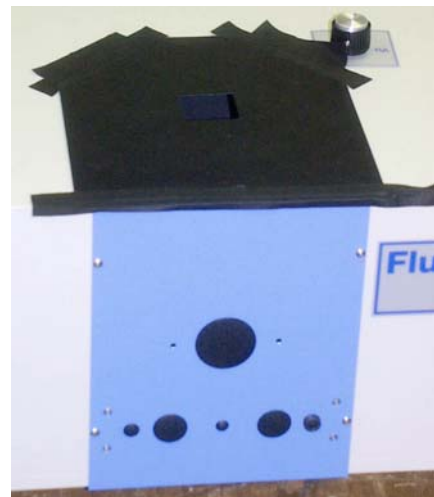

6 Attach the 2 wire ends of the standard lamp to the lamp holder posts.

a The positive (+) lead goes to the positive (red) side of the holder.

b The negative (-) lead goes to the negative (black) side of the holder.

c The nipple of the lamp should point upward.



Warning: Do not touch the lamp. Use cotton gloves or lens paper.

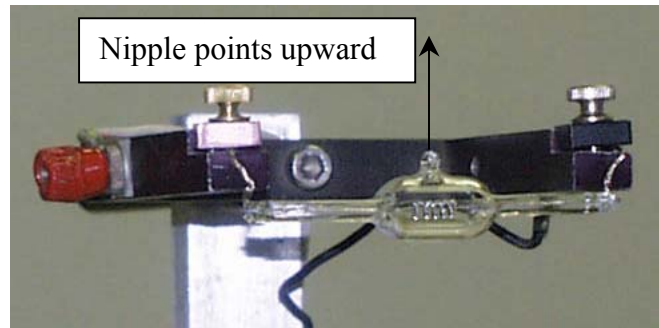

7 Fix the lamp holder to the top of the sample compartment with double-sided tape.

Make sure the the filament is vertically centered over the fixture.

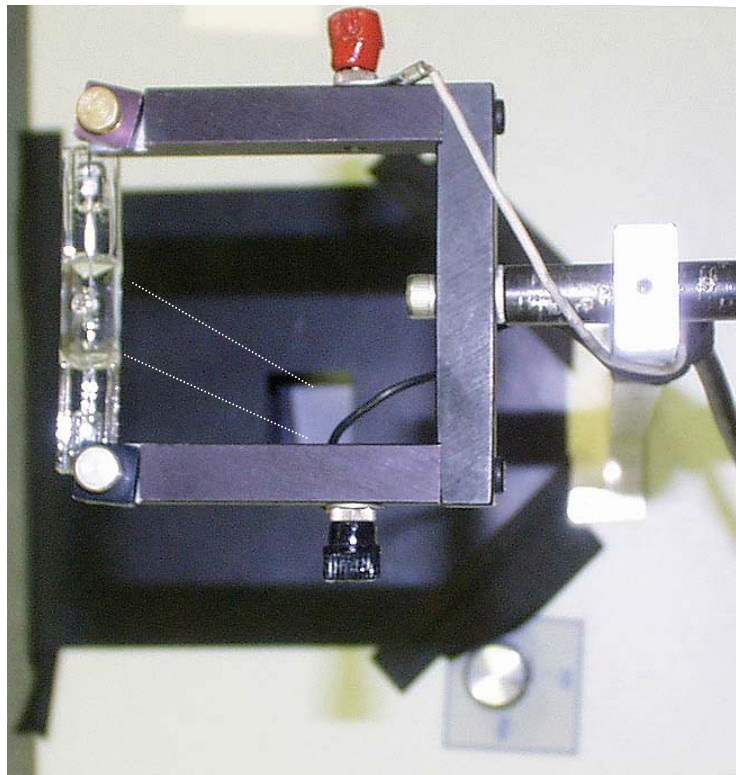

View looking downward from the standard lamp to the mask. Dotted lines (in perspective) indicate how the lamp should be over the square hole.

- 8 Connect the 2 wire leads from the constant-current power supply to the lamp holder.

Attach the red wire to the red clip and the black wire to the black clip, located on the sides of the lamp holder.

- 9 Turn on the constant current power supply. Wait until the current ramp function is 6.5 A.

This may take up to two minutes. For valid irradiance values, the lamp current must be maintained at 6.5 A.



Warning: Avoid looking directly into the lamp's radiation. Wear protective eye-glasses to shield against ultraviolet light.

- 10 Turn off the room lights.
- 11 Set the emission spectrometer to 520 nm, and both emission slits to a 5 nm bandpass.
- 12 Turn on high voltage to the signal detector (HV1).
- 13 Observe the intensity of the signal detector.



Note: The signal level should not exceed 3×10^6 cps—the linear range of the R928P detector—when operated in the photon-counting mode of detection. If necessary, open or close the emission slits to adjust the signal intensity.

A good emission correction factor file depends on ample signal at both high and low points of the lamp spectrum.

- 14 Set the emission spectrometer to 290 nm.

This is the wavelength at which the standard lamp has its lowest light output.

- 15 Check the signal: there should be sufficient intensity above the dark counts.

Determine the dark counts

1 Place the sample lid over the mask to block light to the detector.

2 In **Run Experiment**, select the Experiment button.

This opens the **Emission Acquisition** dialog box.

3 Type in the following parameters in the **Emission Acquisition** dialog box:

Number of Scans	1
Start	290 nm
End	850 nm
Increment	5 nm
Integration Time	1 s
Excitation Position	350 nm

4 Run the standard lamp spectrum.

5 Name this file `stdlamp`.

6 Place the lid over the mask to block the light between the standard lamp and the scatter fixture.

7 Run another scan using the same parameters, and name this file `blank`.

This data file is a straight line with low intensity.

8 Choose Arithmetic from the toolbar.

9 Using the Arithmetic menu, subtract `blank` from `stdlamp`.

10 Name this file `stdlamp2`.

Below are the blank and lamp spectra. Notice that the blank is almost non-existent. Because of the low intensity of the blank file, the blank-subtracted file, `stdlamp2`, will resemble the `stdlamp` file.

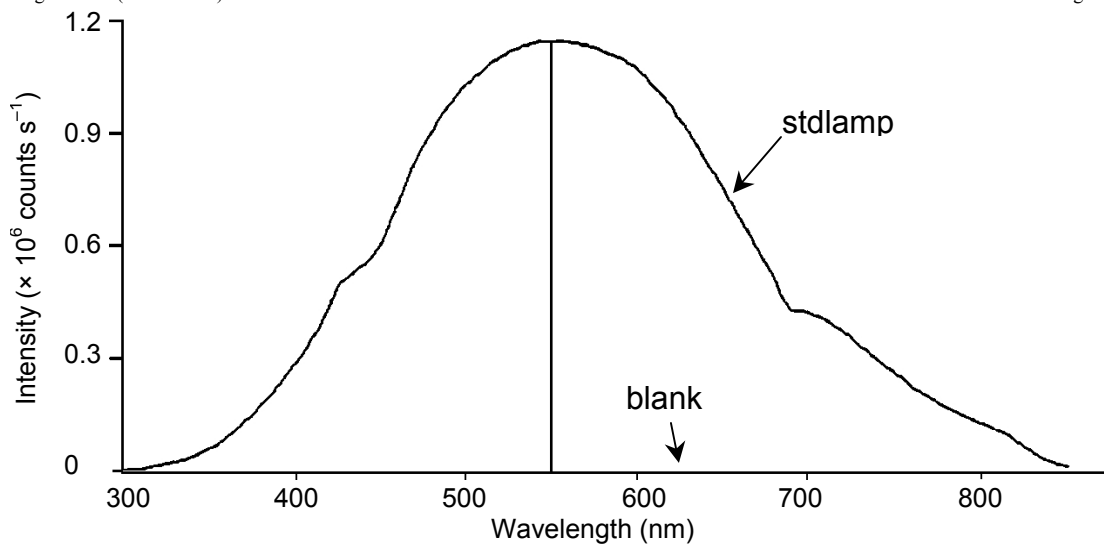

Blank and lamp spectra.

Your spectrum should appear similar to the one pictured above. Its actual appearance, however, depends on the configuration of your Fluorolog[®]-3 system. The lamp scan was acquired with gratings in the emission spectrometer blazed in the visible region and an R928P red-sensitive photomultiplier as the detector. Different gratings or detectors may alter the shape of the lamp spectrum.



Note: Obtaining emission correction factors for the region between 250 nm and 300 nm is possible. Because the gratings are extremely inefficient in this range and the standard lamp output is low, generating these factors is somewhat more involved.

Calculating emission correction factors

Introduction

Irradiance values for a standard lamp, packaged with the lamp, are usually expressed in $10^{-6} \text{ W}\cdot\text{cm}^{-2}\cdot\text{nm}$. With photon-counting systems like the Fluorolog[®]-3 spectrofluorometers, however, data usually are collected in units of $\text{photons}\cdot\text{s}^{-1}\cdot\text{cm}^{-2}\cdot\text{nm}$. To convert the units, multiply each irradiance value by the wavelength at which it is valid. (The data will still be off by a factor of c , but normalizing the correction factors compensates for this.)

For more information about the theory and application of radiometric correction, consult *Accuracy in Spectrophotometry and Luminescence Measurements*, Mavrodineau, Schultz, and Menis, NBS Spec. Publ. 378 (1973), especially p. 137, "Absolute Spectrofluorometry," by W.H. Melhuish.

Load the irradiance values

- 1 In **Run Experiment**, choose the **Experiment** button 

This opens the **Emission Acquisition** dialog box.

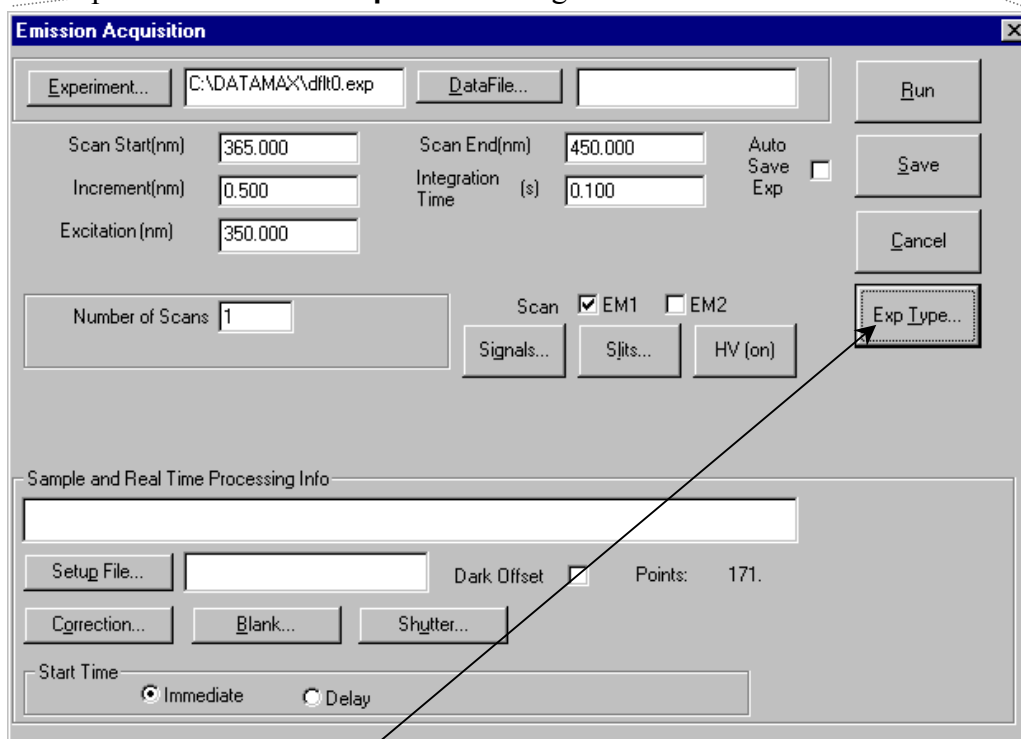

- 2 Click **Exp Type**.

This opens the **Select Experiment Type** dialog box:

3 Choose Emission Acquisition.

Click OK to close the Select Experiment Type dialog box.

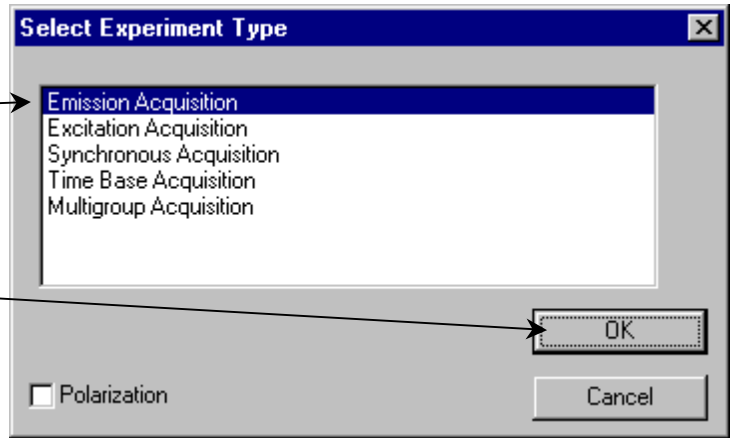

4 Enter the following parameters:

Start the scan at 300 nm.

End the scan at 850 nm.

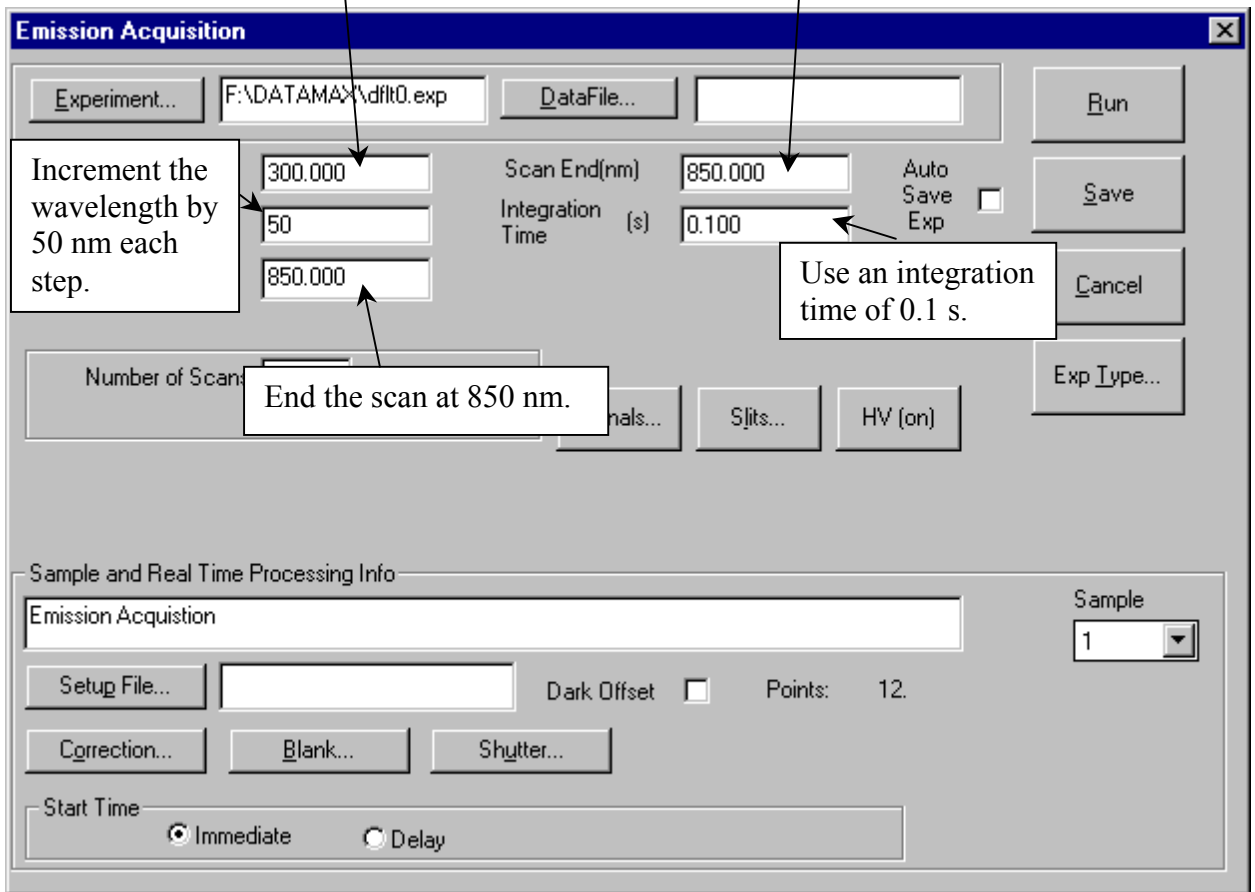

a Click Signals... to open the **Signals** dialog box:

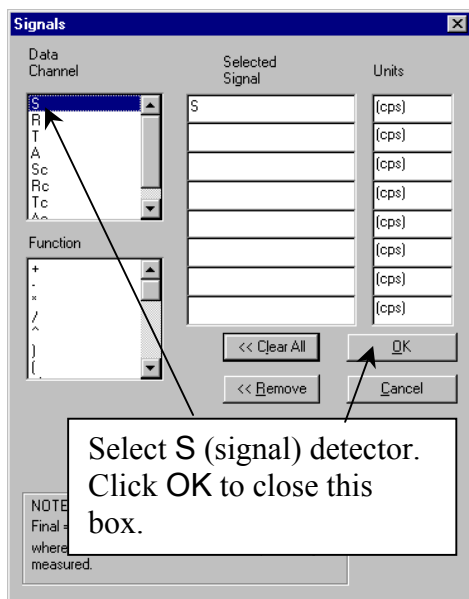

b Click HV to open the **High Voltage** dialog box:

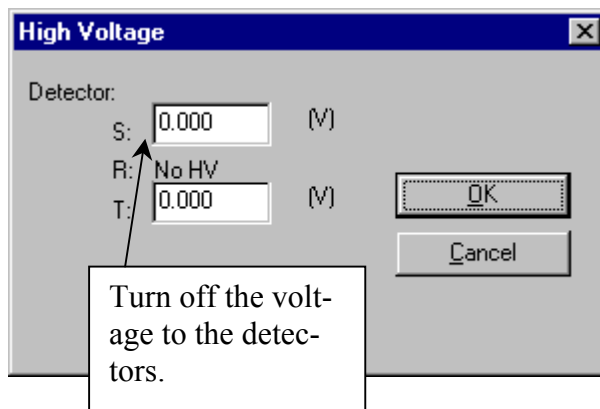

By turning off the high voltage, a file which has 0 intensity for each point will be created. The irradiance values will be entered for each 0 point.

- 5 Run the scan with these parameters.
- 6 Name the file CRE.

After performing the irradiance value multiplication and displaying the file CRE on the screen, enter each value as follows:



Note: Remember to multiply each irradiance value by the wavelength at which it is valid *prior* to attempting to enter its value. The units will be $\text{photons} \cdot \text{s}^{-1} \cdot \text{cm}^{-2} \cdot \text{nm}$.

- 7 Select View from the toolbar.
- 8 Under View, choose Table View.

A table appears, displaying the wavelengths and the value of the intensity at each wavelength. The table may be displayed showing only the last value at the last wavelength. Click on the value (the number will become highlighted), and use the arrow keys to scroll up and down.

Because this file was created with the high voltage off, each intensity value is zero. The irradiance values calculated in a previous step will be entered into the intensity locations for each wavelength.

9 Click on the value to be changed. From the keyboard, type in the calculated irradiance value.

As soon as you begin to type, the **Edit Table** dialog box will appear:

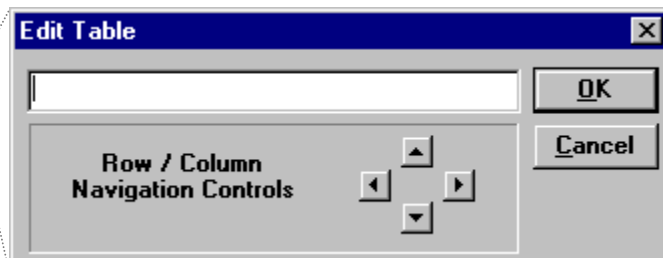

Click on the up and down arrows to move within a column, or click on the left and right arrows to move between columns. After all of the irradiance values have been entered,

10 Click on OK.

The CRE file has the irradiance values incremented every 50 nm. To calculate the actual correction factors, the irradiance file needs to have a 5-nm increment.

11 Using the instructions presented above, create another file.

(Keep the high voltage off.) This time, however, enter 5 nm for the Increment instead of 50 nm. Name this file IRR.

When this scan is complete, the scan range will be from 290–850 nm with an increment of 5 nm. All data points will have intensity values of 0 cps.

12 Using the Arithmetic menu, add the constant 1 to the IRR file and resave it as IRR.

13 Multiply IRR by CRE and resave it as IRR.

This causes the original IRR file to be overwritten. The irradiance values will be spaced every 5 nm as opposed to every 50 nm. The IRR file should look similar to this:

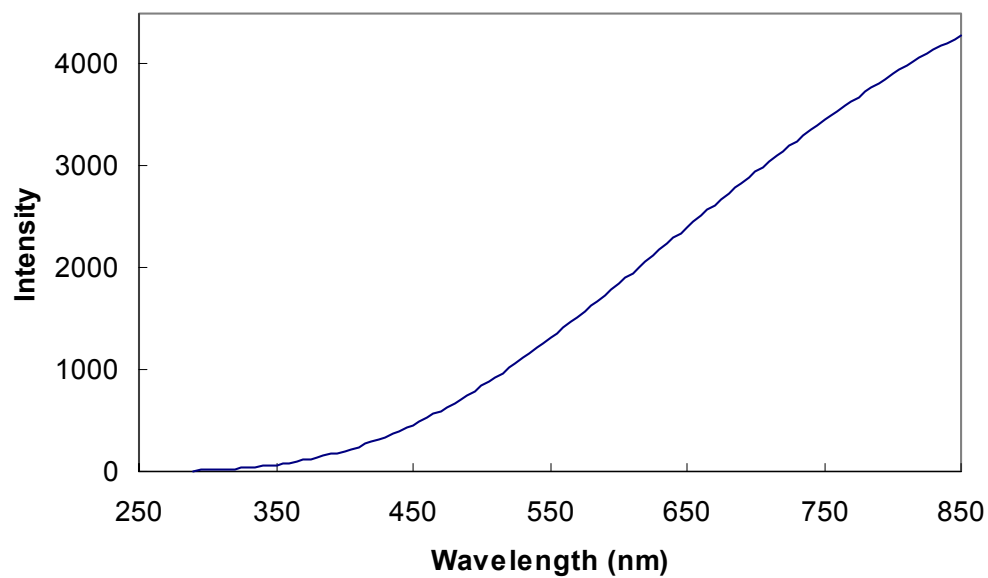

IRR file.

Now you have the two files: IRR and `stdlamp2`. These files are required to calculate the emission correction factors for the Fluorolog[®]-3 system.

Calculate the correction factors

- 1 Using the Arithmetic menu in **Run Experiment**, divide `IRR` by `stdlamp2`, and name the resulting file `mcorrect`.



Note: Naming the file `mcorrect` will overwrite the `mcorrect` file supplied with the software.

Normalize the `mcorrect` file

- 1 Display the `mcorrect` file and find the minimum signal intensity.
- 2 Using the Arithmetic menu, divide the `mcorrect` file by this minimum signal intensity.
- 3 Save this new file as `mcorrect`.

(That is, overwrite the existing `mcorrect` file). This normalizes the correction factor file so that the minimum intensity of `mcorrect` will be 1 count s^{-1} . `mcorrect` contains the emission correction factors for the system. The correction-factor file should look similar to this:

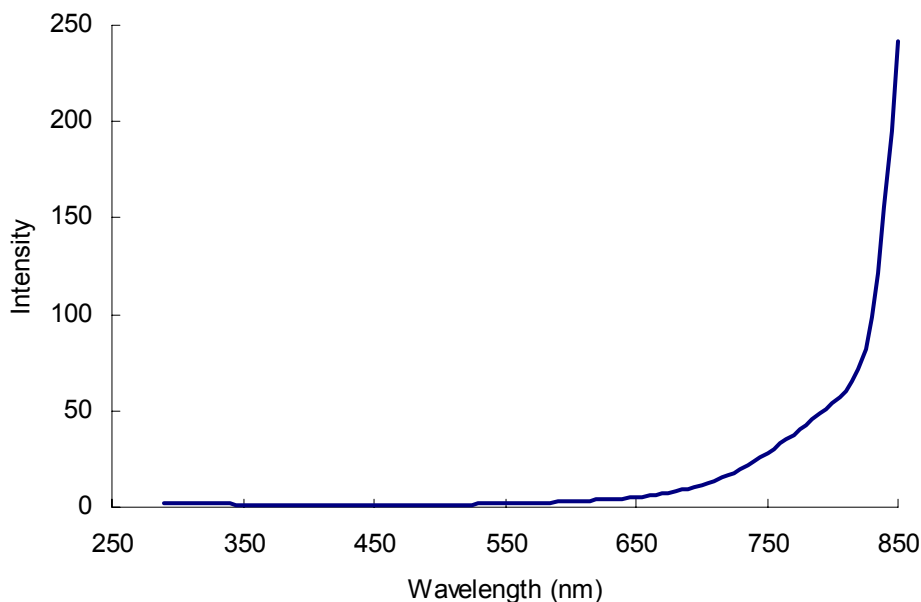

mcorrect File.

The correction factors shown above were acquired for a Fluorolog[®]-3 system with 500-nm blazed gratings in the emission spectrometer and a red-sensitive R928P photomultiplier detector.

Once the emission correction factors have been found, determination of the excitation correction factors may be necessary. The following procedures describe how to obtain excitation correction factors using the photomultiplier and the photodiode. Follow the procedure that applies to your configuration.

Calculating excitation correction factors

The photodiode reference detector handles the bulk of excitation correction from 240–600 nm when a ratio acquisition mode is selected (e.g., *S/R* for single-beam and T-box sampling modules). More accurate measurements require that compensation be applied for the difference in optical path between the detector and the sample. This can be accomplished by a simple excitation scan with rhodamine-B placed in the sample position.

1 Fill a cuvette with a solution of rhodamine-B.

Use 8 g L^{-1} of laser-grade rhodamine-B in 1,2-propanediol.

2 Place the cuvette in the sample compartment.

For single-beam sampling modules, place the cuvette in the standard cell holder and select right-angle detection.

3 Enter the Real Time Display.

4 Set the excitation and emission monochromators to 467 nm and 630 nm, respectively.

The largest lamp peak occurs at 467 nm.

5 Set the two slits on the excitation spectrometer to 0.5 mm.

6 Make sure the shutter is open.

7 Set the excitation monochromator to 560 nm and the emission monochromator to 630 nm.

8 Adjust the slits on the emission monochromator.

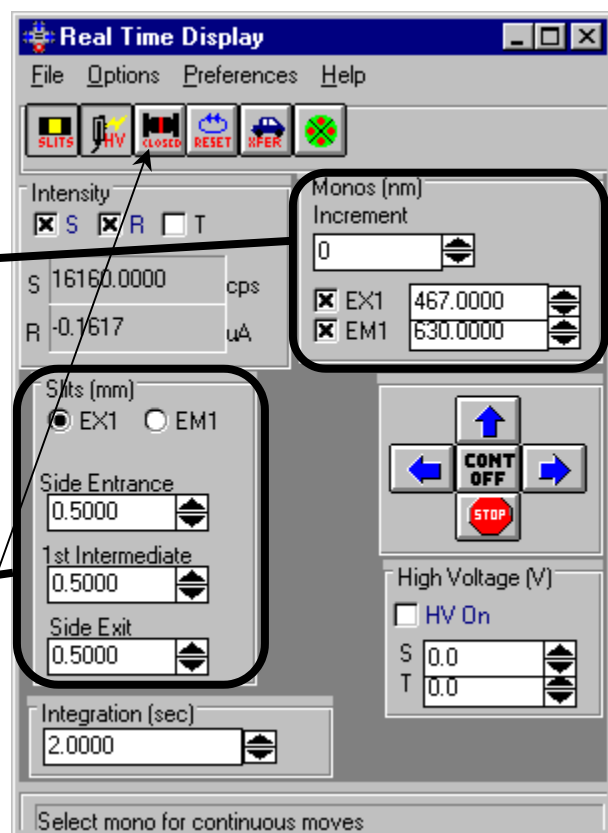

The slit width discovered in this step will be used to run the scan.



Note: Obtain a signal intensity of no greater than 1.5×10^6 cps.

- 9 With the **Real Time Display** still running, open **Run Experiment**.
- 10 In **Run Experiment**, choose **Collect**.
- 11 Under **Collect**, choose **Experiment**.

This opens the **Emission Acquisition** dialog box:

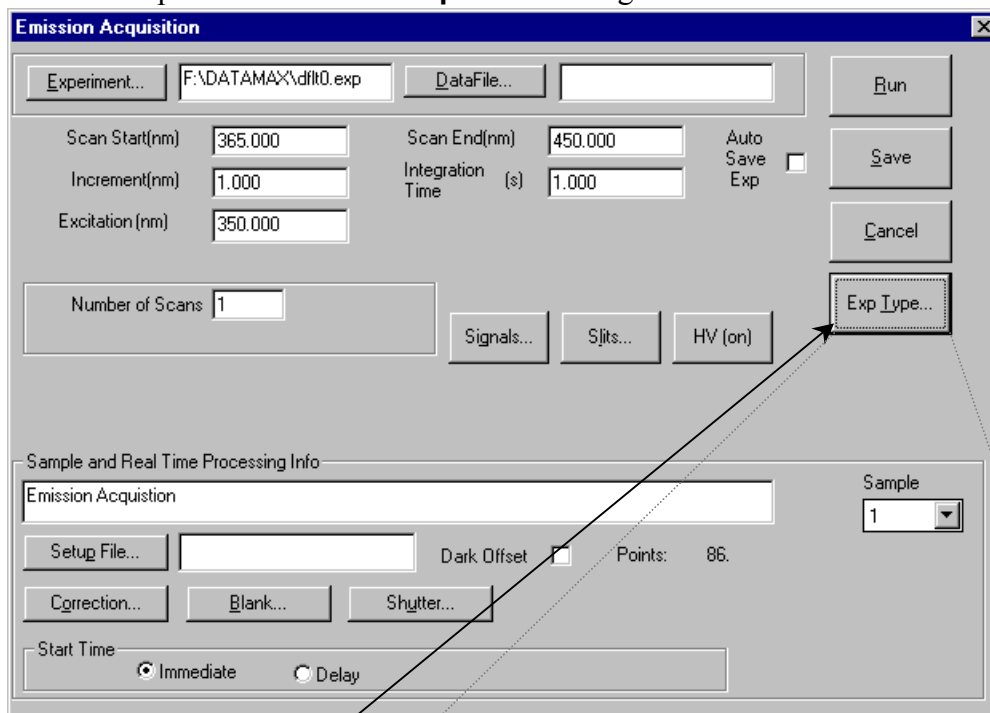

- 12 Click **Exp Type**.

This opens the **Select Experiment Type** dialog box:

- 13 Choose **Excitation Acquisition**, then **OK**.

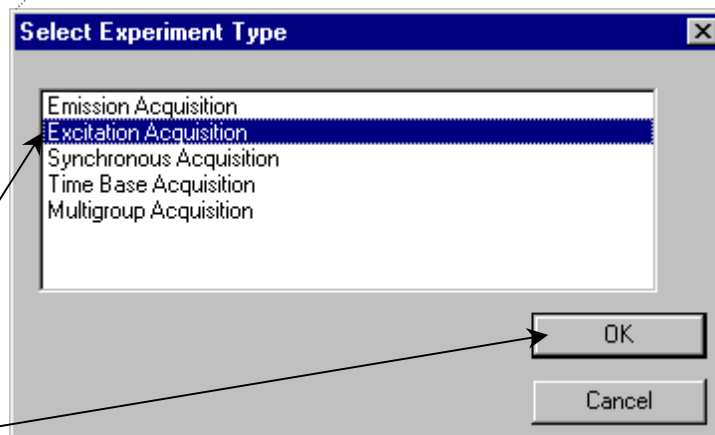

This closes the **Select Experiment Type** window, and then resets the **Emission Acquisition** dialog box to **Excitation Acquisition**.

14 Click Signals....

This opens the **Signals** dialog box:

15 Enter S/R as the Selected Signal.

Click OK to close the **Signals** box.

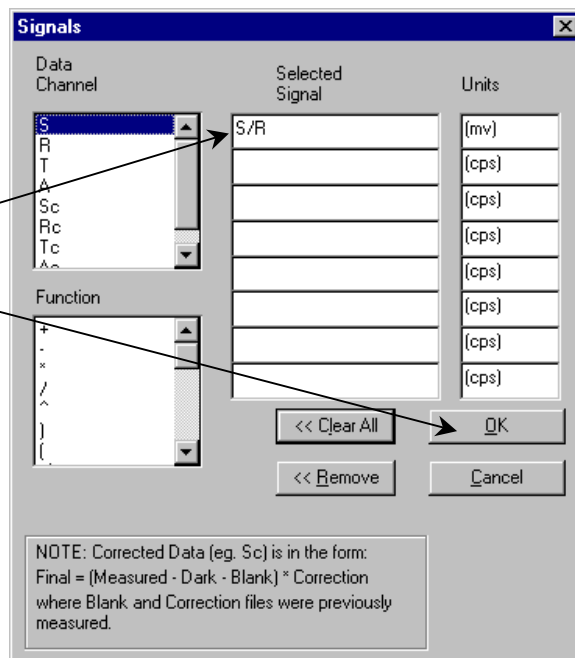

16 Click Slits....

This opens the **Slits** dialog box:

17 Use the XFER button  in the **Real Time Display** to move the slit widths to **Slits**.

Click OK to close the **Slits** window.

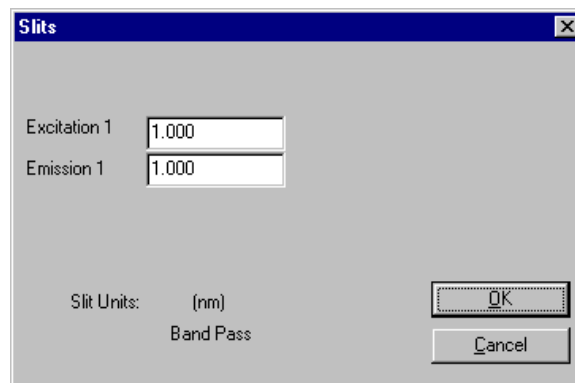

18 Click HV.

This opens the **High Voltage** dialog box:

19 Use the XFER button  to move the high voltages to **High Voltage**.

Click OK to close the **High Voltage** window.

20 Enter the remaining parameters in the **Excitation Acquisition** window:

Start the scan at 240 nm.

End the scan at 600 nm.

Increment by 5 nm after each data point.

Set the Integration Time to 5 s.

Perform one scan.



Note: Be sure the Auto Zero function is on.

21 Click Run to execute the scan.

22 Save the file as
xcorrect.



Note: Doing so replaces the xcorrect file that was shipped with the system.

23 If no zeroes are shown, invert the data.

In **Run Experiment**, use the Arithmetic menu to divide the spectrum into 1.

24 Normalize the data.

Find the minimum data point and divide the file by that value.

25 Save the normalized file as `xcorrect`.

This overwrites the existing excitation correction-factor file.

To acquire corrected data for an experiment, enter the name of this file in the **CORRECTION** factor file field in the **Data Acquisition Parameters** dialog box. The **CORRECTION** factor file must be in the same directory as the data to be acquired and corrected.

12: Determining the Plateau Voltage

Introduction

The *plateau voltage* is the voltage at which the signal intensity is maximized, while the dark-count intensity is minimized. The emission signal detector requires a voltage input to operate. The operating voltage determines the sensitivity of the detector. To achieve the highest sensitivity possible, the plateau voltage determination should be performed whenever a new detector is installed.

Approximately 30 min are needed to acquire the data and 15 min to display the data in the form of two data files.



Note: In the standard configuration, the software supplies a maximum voltage of 1200 V to the detector(s). Certain applications (IR fluorescence measurements, for example) require detectors with operating voltages near 1450 V. In these cases, the standard high-voltage board should be replaced with an optional board that increases the high-voltage output to 2000 V.

Overview of the procedure

- 1 Compose a table with dark counts and corresponding signal intensities at incremental voltages.
- 2 Construct a graph. Note the point at which the signal intensity is maximized and the dark-count intensity is minimized.

This is the *plateau voltage*, the point at which the highest sensitivity of the detector is achieved.

To record the values, construct or photocopy the following table:

High Voltage (Volts)	Signal (cps)	Dark Counts (cps)
650		
700		
750		
800		
850		
900		
950		
1000		
1050		
1100		
1150		
1200		

Procedure

Set up the instrument

- 1 Turn on the xenon lamp, Fluorolog[®]-3 system, peripherals, and computer.
- 2 Enter the DataMax software.
- 3 Run a xenon-lamp spectrum and the water Raman scans.
Do water Raman scans both right-angle and front-face to ensure that the system is functioning properly.
- 4 Enter the **Real Time Display**.
- 5 Set the slits of the excitation and emission spectrometers to a bandpass of 5 nm.
- 6 Insert a cuvette filled with distilled water in the sample holder.
- 7 Select right-angle detection.
Turn the selection mirror knob located on top of the sampling module to RA.
- 8 Set the Integration Time to 2.0 s.
- 9 Position the excitation and emission spectrometers to 350 nm and 397 nm, respectively. Click on the check boxes to activate them.
- 10 Display the **High Voltage** dialog box by clicking on the icon.
- 11 Turn on HV1 (signal detector or S voltage).

Record the signal from 650 V to 1200 V.

- 1 Open the programmable excitation shutter by clicking on the shutter icon.
- 2 Enter 650 V in the S voltage text box.
- 3 Click on the right arrow on the **Continuous** area.

This records data in Prompt-Step mode (see the DataMax manual for details).

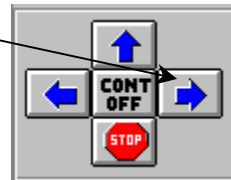

- 4 Record the signal in cps at 650 V in a table such as the one shown on a previous page.

This intensity will be the same value as the intensity at the peak of the water Raman scan acquired, using right-angle detection and the specific high voltage.

- 5 Close the shutter by sliding it to the right.

This closes the manual shutter on the variable exit slit of the emission spectrometer.

- 6 Record the dark counts at 650 V.

Write this value next to the signal intensity in your table.

- 7 Open the shutter by sliding it to the left.

- 8 Change the high voltage of the signal detector from 650 V to 700 V.

- 9 Repeat steps 3 through 8,

increasing the signal detector voltage by 50 V each time and recording the signal intensity and the corresponding dark counts.

The sample data below were acquired using a Fluorolog[®] Model FL212 equipped with a 450-W xenon lamp and an uncooled signal detector.

High Voltage (Volts)	Signal (cps)	Dark Counts (cps)
650	8.7×10^4	150
700	1.28×10^5	260
750	1.52×10^5	350
800	1.68×10^5	480
850	1.74×10^5	420
900	1.80×10^5	450
950	1.81×10^5	490
1000	1.96×10^5	530
1050	1.96×10^5	640
1100	2.05×10^5	560
1150	2.12×10^5	640
1200	2.25×10^5	710

Determine the plateau voltage

- 1 From the data obtained, construct two graphs: Signal versus Voltage, and Dark Counts versus Voltage.

Graphs of the above data are shown here, stacked into one combined graph.

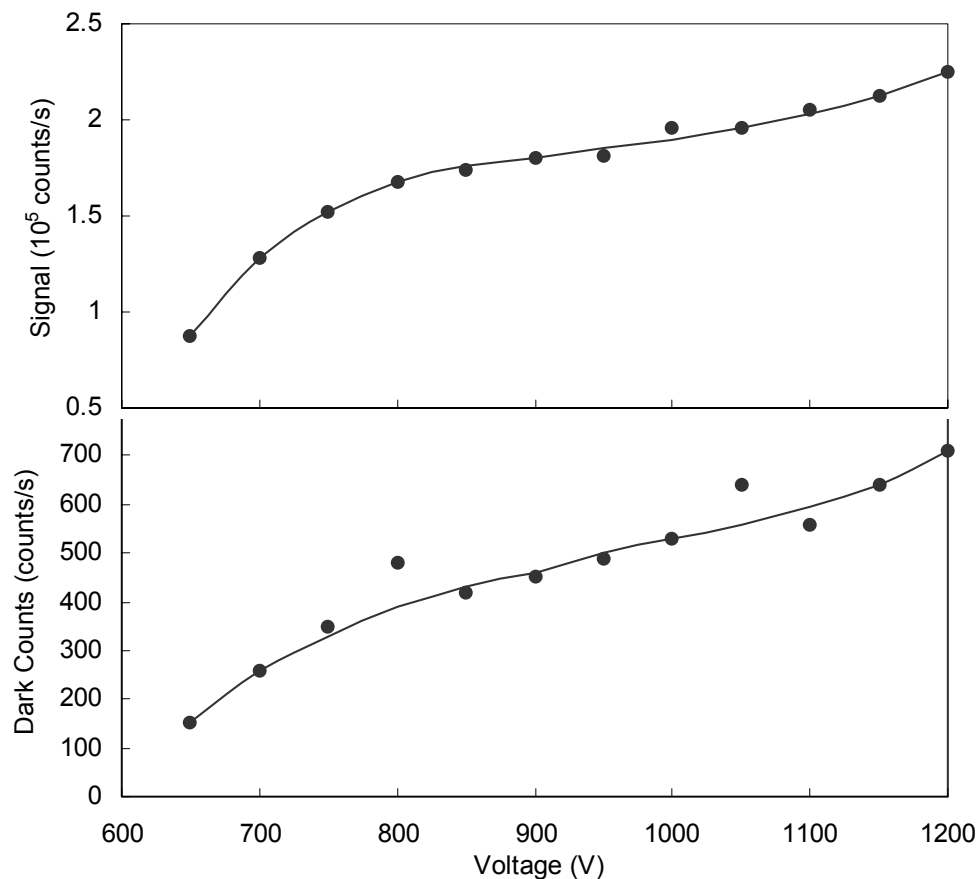

From these graphs, at ~1000 V there is a plateau both in the signal and dark counts. Therefore, the point at which there is maximum voltage with minimum dark counts is 1000 V—the plateau voltage for this detector.

13: Reassembly Instructions

The Fluorolog®-3 system consists of four main components:

- Personal computer
- Color monitor
- Expanded keyboard
- Fluorolog®-3 spectrofluorometer

An optional printer may also be included. The Fluorolog®-3 spectrofluorometer is a combination of discrete modules and components. These components include excitation and emission monochromators, sample compartment, xenon light source and a System Controller (SAC).

Occasionally, because of relocating the instrument, reassembling the system is necessary. The following instructions are provided as a guide.

Computer

The computer must be set-up and operating before the spectrofluorometer system can be connected.

- 1 Connect the computer's components according to the instructions with the computer.



Note: The computer's COM1 port will be connected to the System Controller in a later step. Make sure this port is available.

- 2 Plug the power cables from the monitor, the main unit (CPU), and the printer or plotter into outlets with the proper line voltage.



Warning: Do not turn on the computer or the peripherals.

Spectrofluorometer assembly

Once the computer has been assembled, the external components of the Fluorolog[®]-3 spectrofluorometer must be connected. The modules of the Fluorolog[®]-3 fit together in a seamless configuration. Each module and the lamp housing has alignment studs, alignment receptacles, and D-connectors on the outside of the housing:

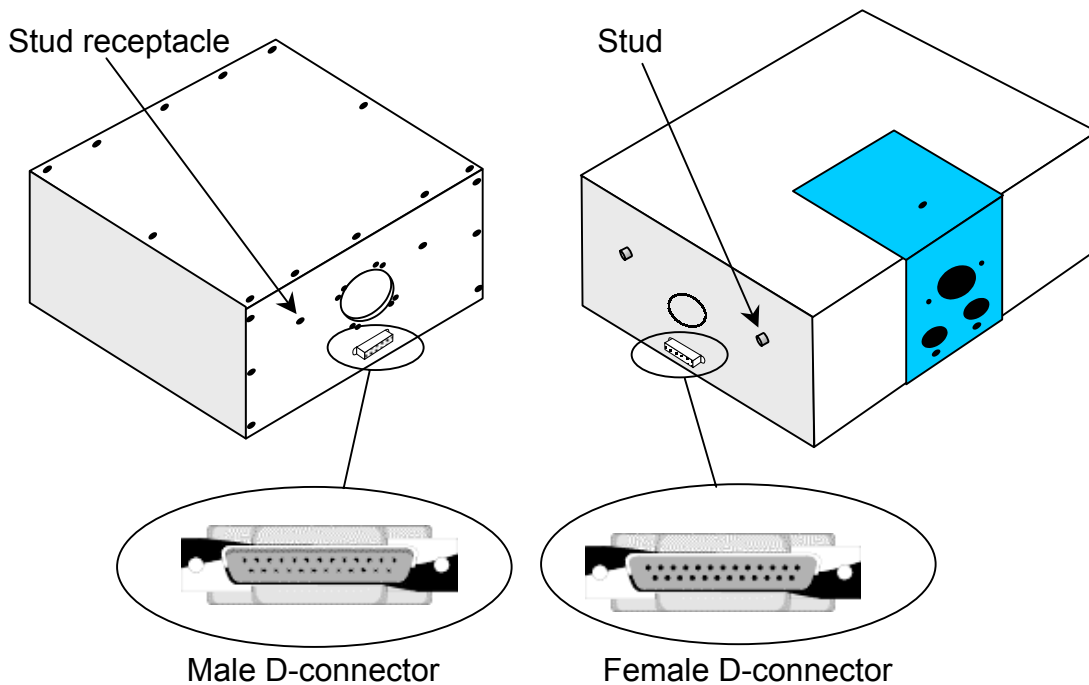

1 Assemble the spectrofluorometer system's modules into the proper configuration.

That is, attach the spectrometers to the sample compartment, and the lamp housing to the excitation monochromator.

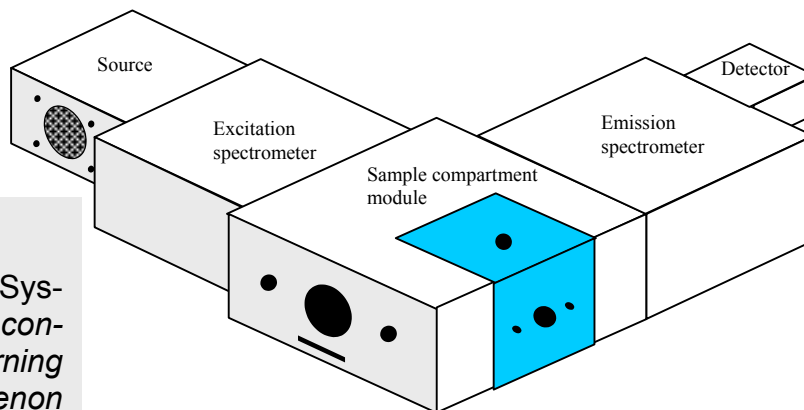

Example of a Fluorolog[®]-3 configuration.



Note: See Chapter 2, System Description, for configurations. Concerning the lamp housing, xenon sources, and cautions, see Chapter 5, System Maintenance.

Cable connections

These connectors connect the spectrofluorometer components with the System Controller (SAC) and the computer system.



BNC Connector

D-shell Connector

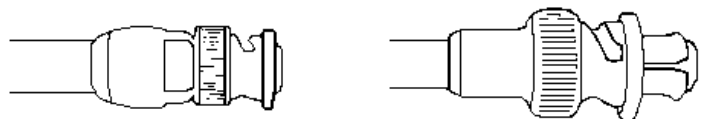

MHV Connector

SHV Connector

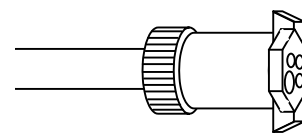

4-Pin Circular Connector

The jacks on the rear of the SAC are shown to the right:



Note: The actual layout of connections on the rear of the SAC may vary, depending on the system's configuration.

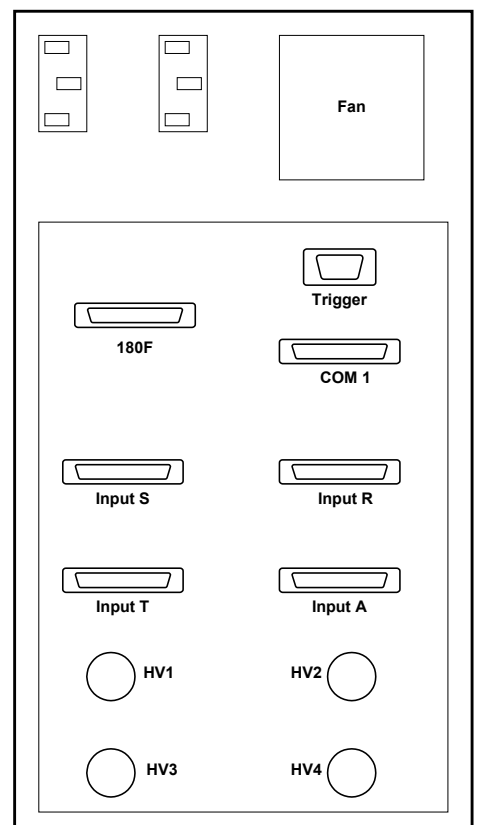

Rear of SAC

The cable diagram below shows the path of each cable. During installation, refer to the schematic to ensure proper system interconnections.

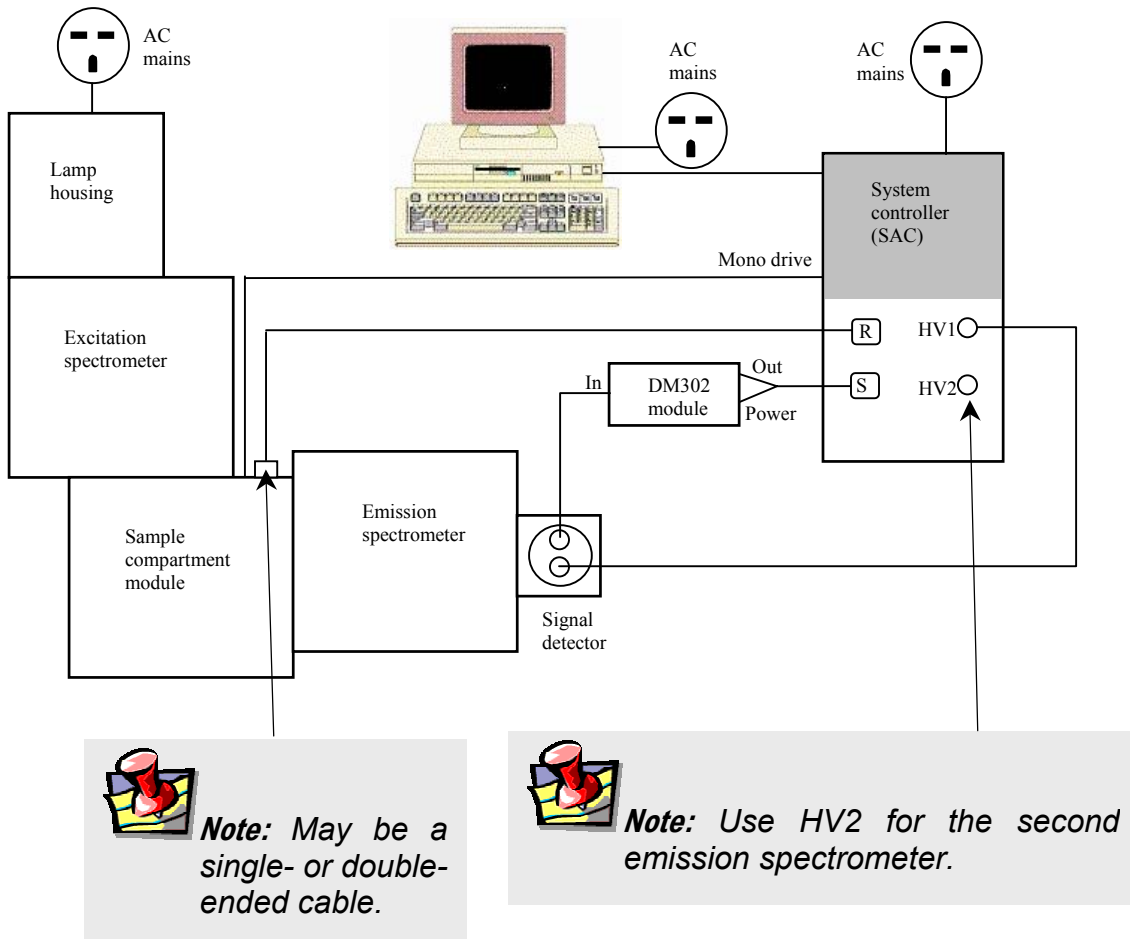

Connecting the reference detector to the SAC

The Fluorolog[®]-3 spectrofluorometer system comes standard with a silicon-photodiode reference detector inside the sample-compartment module. The connections to the reference detector are on the outside front of the sample compartment module. The sample compartment module (reference detector) is joined with the SAC via a split cable; that is, a cable with three ends.

- 1 Find the double-headed end of the split cable #33979A.
- 2 Plug the end with the 7-pin D-shell connector into the D-shell jack on the front of the sample compartment module. Plug the BNC plug into the BNC jack next to the D-shell jack.
- 3 Plug the remaining D-shell end of the cable into the INPUT R connector on the back panel of the SAC.



DM302 PC module and signal-detector connections

- 1 Plug the end of the high-voltage cable #34040 with the MHV connector into the signal detector.
- 2 Connect the other end to the HV1 SHV connector on the SAC.
- 3 The DM302 PC module has three plugs labeled SIGNAL OUT, POWER and IN. Plug the short cable #30645 with the BNC connector from the signal detector to the IN connector on the DM302.

The DM302 is joined to the SAC via the split cable #33977.

- 4 Take the end of the #33977 cable that has two connectors.
- 5 Plug the end with the 4-pin circular connector into the POWER jack of the DM302, and the BNC plug into the OUT jack of the DM302.
- 6 Plug the remaining end of the #33977 cable into the INPUT S connector on the back panel of the SAC.

Sample compartment module

- 1 Insert the 25-pin–9-pin cable #400108 between the sample compartment and the jack labeled “mono drive” on the SAC.



Note: With special options (e.g., trigger accessory), there may be an additional cable connection. Refer to the accessory's instructions.



Lamp power supply

The lamp power supply is integrated into the lamp housing. No additional connections are required.

Computer to SAC

The spectrofluorometer system is controlled via the SAC through the computer.

- 1 Connect the 9-pin–9-pin connector cable between COM1 of the computer and COM1 of the SAC.

Connecting power cables

Several components in the system have AC power cables. These items include:

- SAC
- Computer (and peripherals)
- Lamp
- System Accessories (such as MicroMax[®], temperature bath, etc.)

1 Plug the AC components into a properly rated receptacle or power strip.

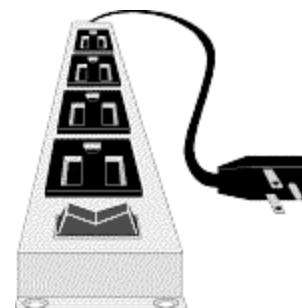

- Calibrate the system before conducting an experiment. Refer to the appropriate chapter for calibration instructions.
- To properly operate the equipment, have a complete understanding of the software. Read the software manuals to gain an understanding of the system interaction, and to discover the best methods to unleash the power of DataMax.

14: TRIAX operation with the Fluorolog®-3

Introduction

Some users choose the TRIAX series of imaging spectrometers as a building block in a Fluorolog®-3 spectrofluorometer. Using a TRIAX imaging spectrometer on the emission side of the sample mount offers the option of detection with a CCD, to create an image of the dispersed fluorescence for subsequent analysis. This chapter discusses special hardware connections and software operation specific to TRIAX users, especially with regard to CCD detectors.

Fluorolog®-3 TRIAX users should note these major differences between the TRIAX and standard monochromators:

- Four ports generally are available, rather than two on a standard monochromator. Most TRIAX spectrometers used with the Fluorolog®-3 have two entrance ports (“lateral”, i.e., on the side, and “axial”, i.e., on the back) and two exit ports (lateral and axial). Usually the lateral entrance port is attached to the sample compartment.

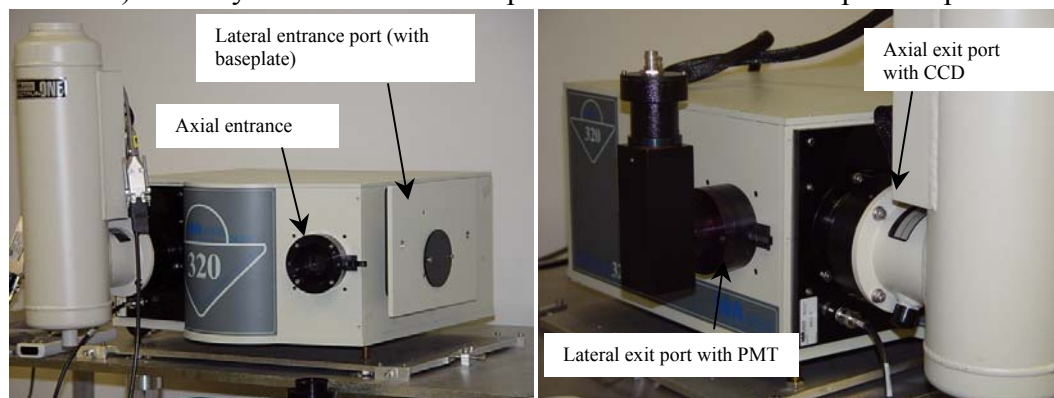

- A DataMax-controlled flip mirror is available to choose between entrance ports and exit ports. Be sure the flip mirror is set to the proper position before running an experiment.
- Three gratings can be mounted on the rotatable grating turret. Choosing which grating to use is under DataMax’s control.

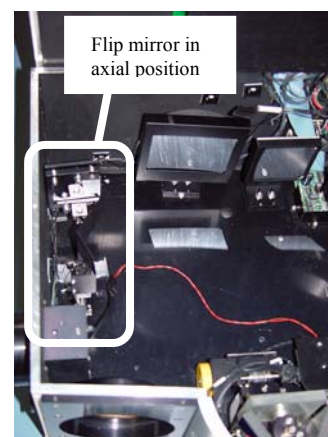

Hardware

Electrical power

Have a free AC (mains) outlet available

for the TRIAX. A 24-V adapter and power supply plugs into the AC circuit, and connects to the back of the TRIAX. The power supply contains a voltage converter that automatically adjusts to the input AC voltage.



Warning: Some users may wish to remove the monochromator and replace it with a TRIAX. Always switch off the power to the monochromator and TRIAX before removal of these accessories from or addition to a system. Failure to shut off the power to the TRIAX and monochromator can damage the SpectrAcq.

Internal workings

Multiple gratings

Generally, gratings with different groove-densities are installed, but gratings with different blaze-angles are also possible for custom applications. Rotation to a new grating is discussed in **Visual Instrument Setup** below. After installing a new grating on the turret, its groove density must be entered in **Visual Instrument Setup**, and its calibration must be performed in **Visual Instrument Setup**. Both of these procedures are described later in this section.

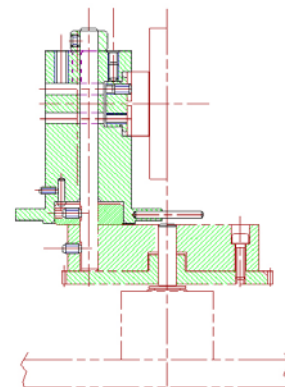
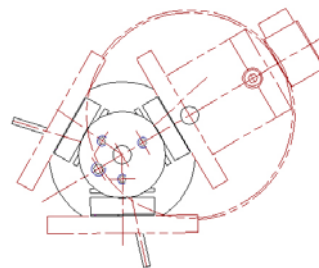

Turret removal

- 2 Grasp turret by the thumbscrew on top.



Warning: Never touch the face of a grating!

- 3 Lift the turret up and out of the instrument.
- 4 Leave one shim-washer on the shaft.

Turret installation

- 5 Reverse steps 1 to 3. The turret is self-indexing, so the initial position does not matter.
- 6 Rotate turret until it rests in a depression. When switched on, the turret rotates to the correct position.



Warning: Leave clearance under the collar when replacing the top shim-washer. This ensures free rotation of the turret. The turret rises several mm when it switches gratings. If the collar is too tight, it causes the motor to grind. This may damage the drive mechanism.

Automated slits

The TRIAX has automated adjustable slits at the entrance (2 mm maximum) and exit (7 mm maximum) ports. The slit width may be adjusted in steps of 0.0125 mm. For a 0.6-mm slit on the TRIAX 320, dispersion is 1.58 mm.

Connections to system

Below is a sketch of the special cable connections required between a TRIAX spectrometer, the CCD detector, and the system. Details of these connections are given on the following pages. Other Fluorolog[®]-3 connections are not shown.

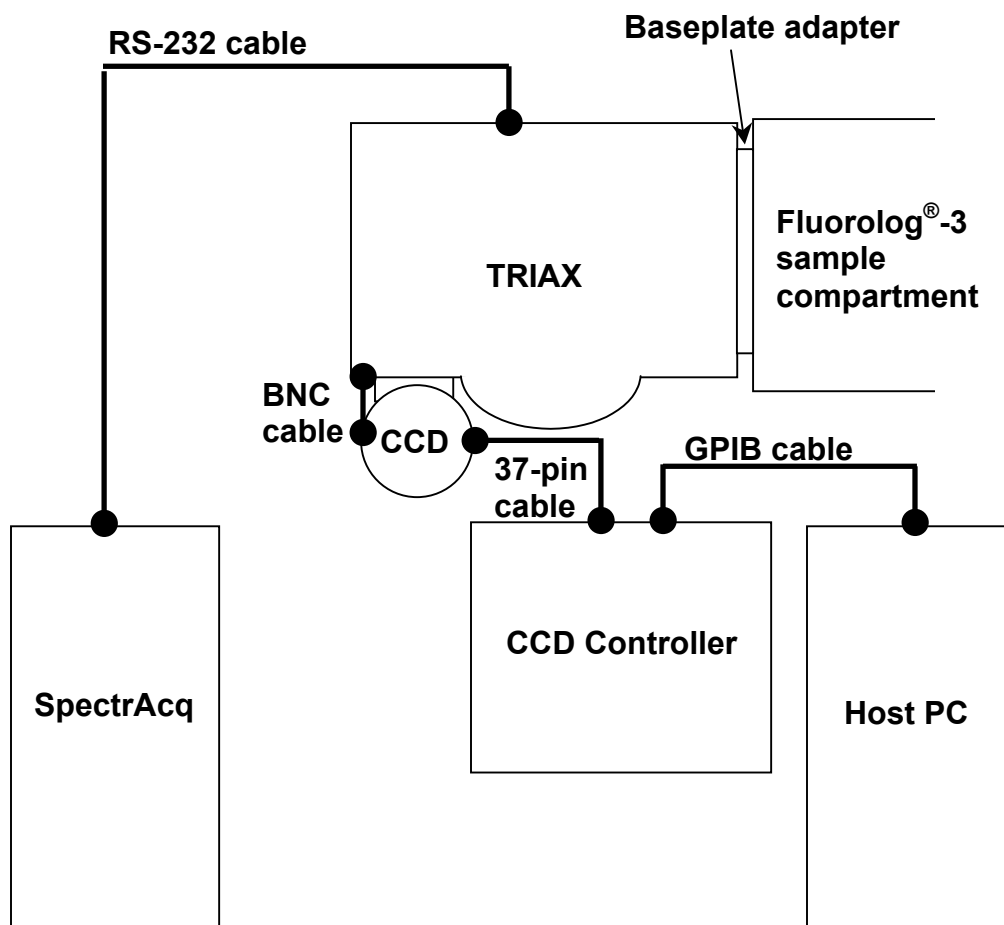

Attachment to sample compartment

Fluorolog[®]-3 users typically choose the lateral entrance port as the path for luminescence from the sample compartment into the TRIAX. To attach the TRIAX to the sample compartment, a baseplate adapter must be inserted between the sample compartment and the TRIAX.

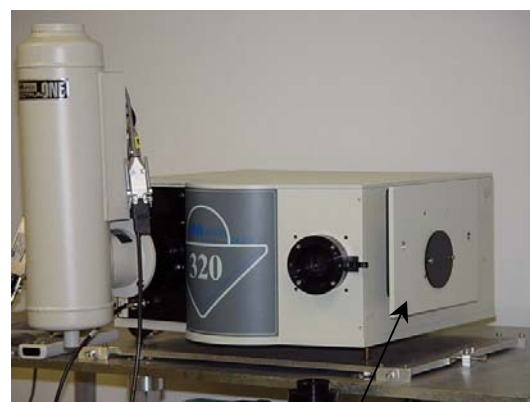

Baseplate attached to lateral entrance port.

Communication between TRIAX and SpectrAcq

A cable runs between the TRIAX and SpectrAcq for proper communication. To the right is a photograph of the cable attachment to the TRIAX.

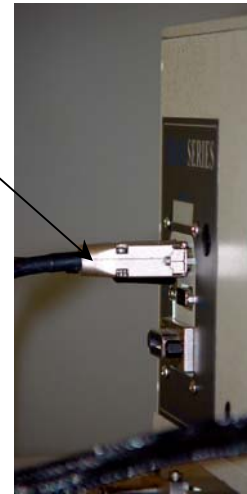

Cables to CCD detector

A coaxial cable runs from the terminal on the back of the TRIAX to the CCD. This controls the CCD shutter. The large 37-pin cable (bound together with the coaxial cable) carries data between the CCD controller and the CCD chip inside the detector.

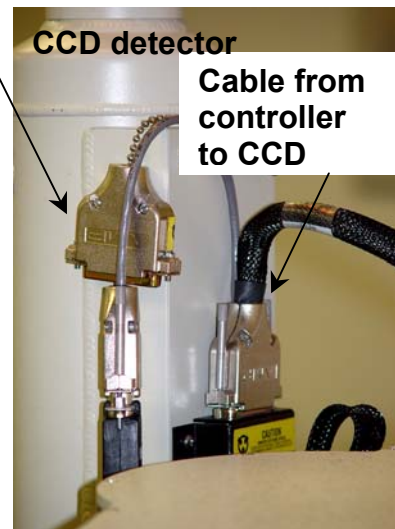

CCD controller

A GPIB cable connects between the CCD controller and the host computer.

Cable between controller and CCD chip

GPIB cable from controller to host PC

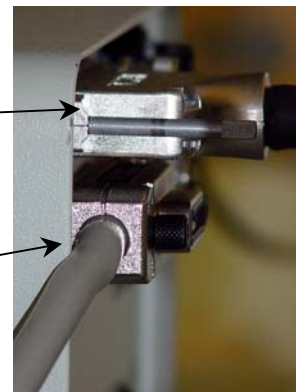

Back of CCD controller

Software

Visual Instrument Setup

The TRIAX appears as a standard monochromator icon within **Visual Instrument Setup**'s instrument layout.

Moving the flip mirrors

For those TRIAX accessories with dual entrance and exit ports, the flip mirrors to choose which entrance and exit ports are controlled in DataMax.

- 1 Click on the mirror icon.

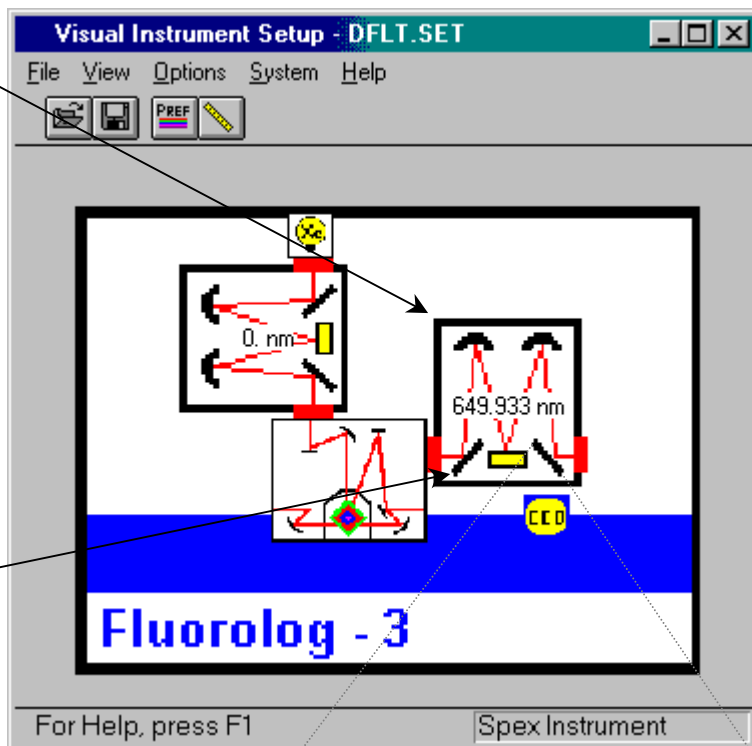

The **Entrance** or **Exit Mirror** dialog box appears.

- Lateral = side port
- Axial = rear port

- 2 Click Change to move the mirror to the other port.
- 3 Allow several seconds for the mirror to move.
- 4 Click Close.

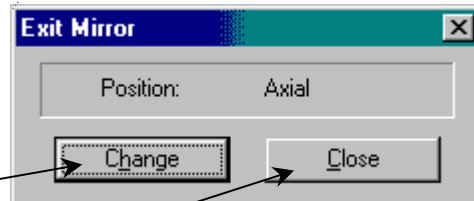

The **Mirror** dialog box closes.

Rotating the turret to a different grating

- 1 Click the grating icon.

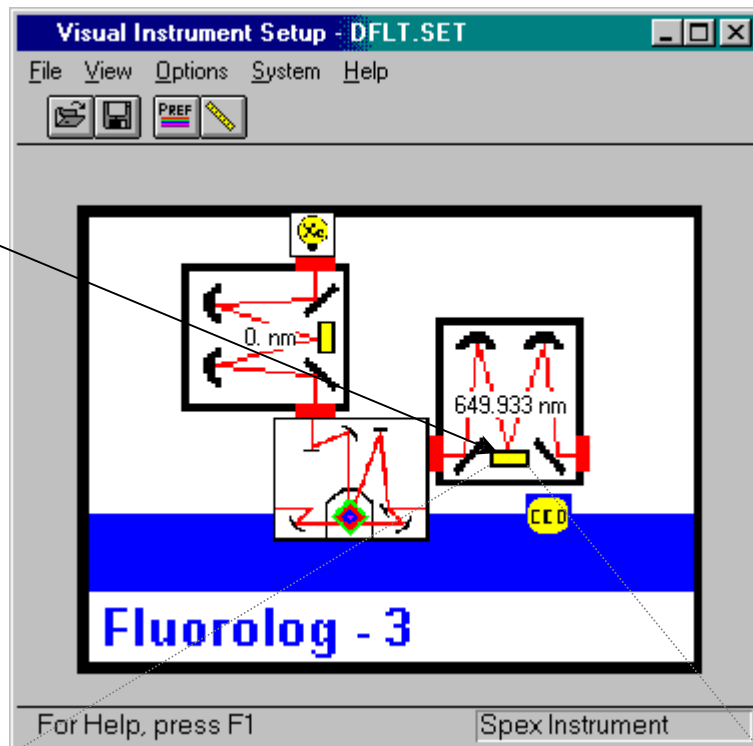

The **Grating/Turret** window opens.

- 2 Click the desired grating's radio button.

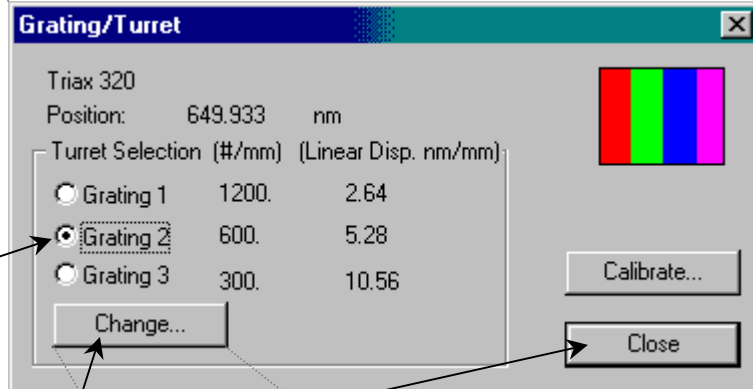

Allow several seconds for the turret to rotate to the new position.

- 3 Click Close.

Installing a new grating on the turret

- 1 Follow instructions in the *TRIAX Series User Manual* on replacing the grating.

- 2 Click Change....
The **New Value** dialog box appears.

- 3 Enter the new grating's groove density.

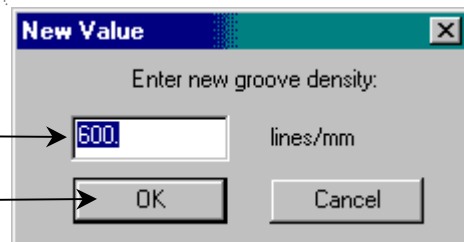

- 4 Click OK.

The **New Value** dialog box closes.

5 Run a scan with the grating, to find a known peak.

Jobin Yvon Inc. suggests running a xenon-lamp scan to find the 467-nm peak, or a water-Raman scan to find the 397-nm peak. This procedure is similar to that given in Chapter 3.

6 Note the position of the found peak.

As an example, we assume a lamp scan was performed, and the 467-nm peak was observed at 480 nm.

7 Open the Real Time Display.

8 Enter the observed peak position.

Don't forget to hit the Enter key. Here, we entered 480 nm, the position where the 467-nm peak was seen.

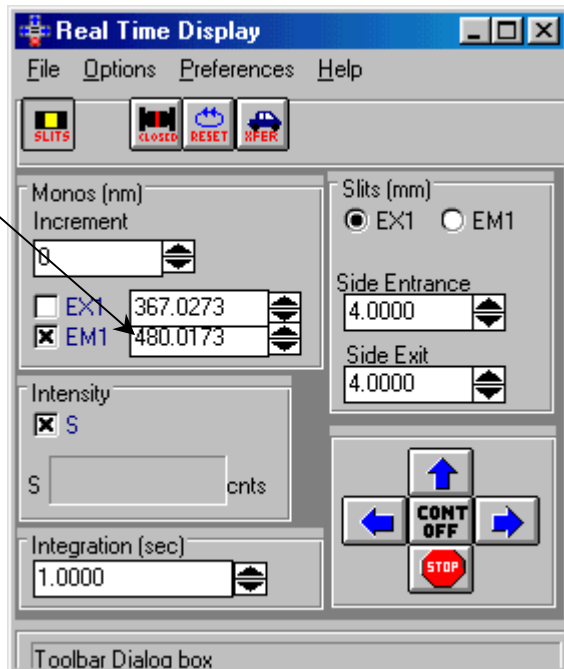

9 Close the Real Time Display.

10 Click Calibrate....

The **Enter Correct Position** dialog box opens.

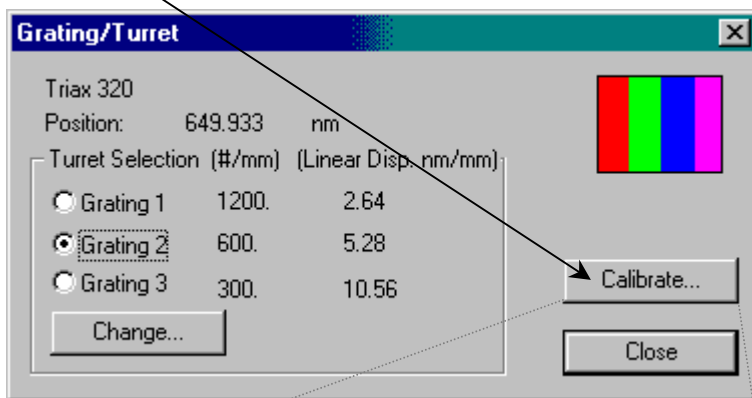

11 Enter the true peak position.

12 Click OK.

The **Enter Correct Position** dialog box disappears.

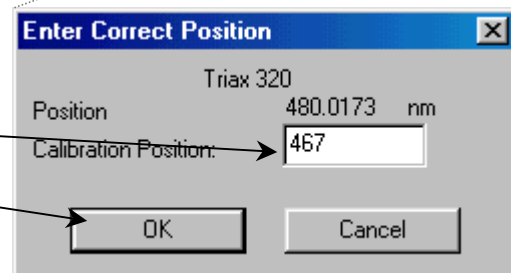

Adjusting slit widths

- 1 Click on an icon of a slit.

 **Note:** A CCD is mounted on the side (lateral) exit, while a PMT is mounted on the front exit.

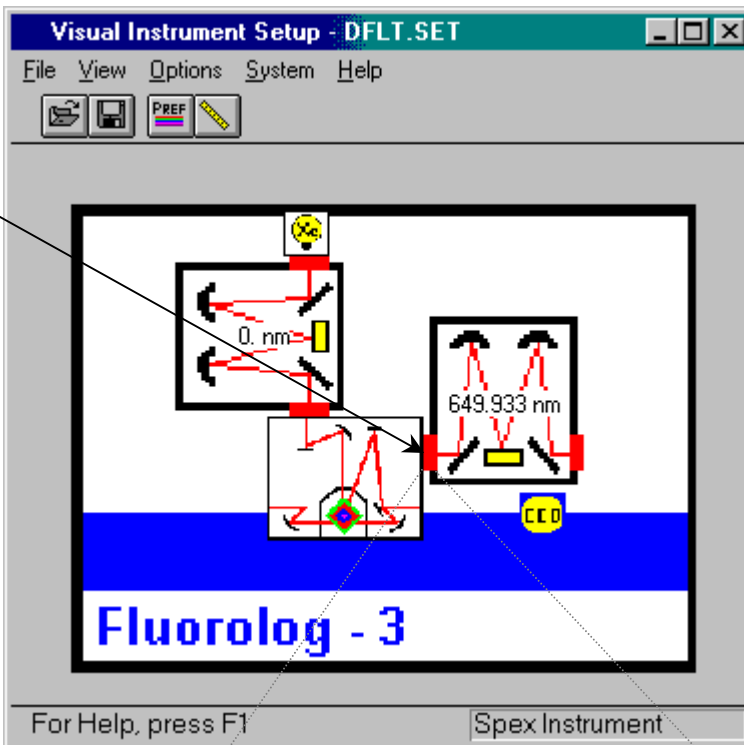

The **Slits** window opens. All slits in the TRIAX are adjustable, no matter which slit you click.

- 2 Enter the desired slit width.

 **Note:** The exit slit-width parameter is valid only for PMT users. For CCD detectors, there is no slit at the exit of the TRIAX, so any displayed settings are superfluous.

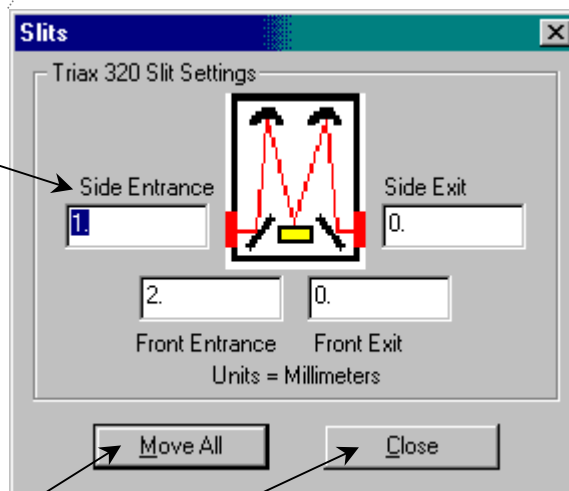

In bandpass units (e.g., nanometers), all slits have the same setting.

- 3 Click **Move All**.
This implements the change.
- 4 Click **Close**.
The **Slits** dialog box closes.

CCD Detector

The CCD detector has a special symbol in the Visual Instrument Setup:

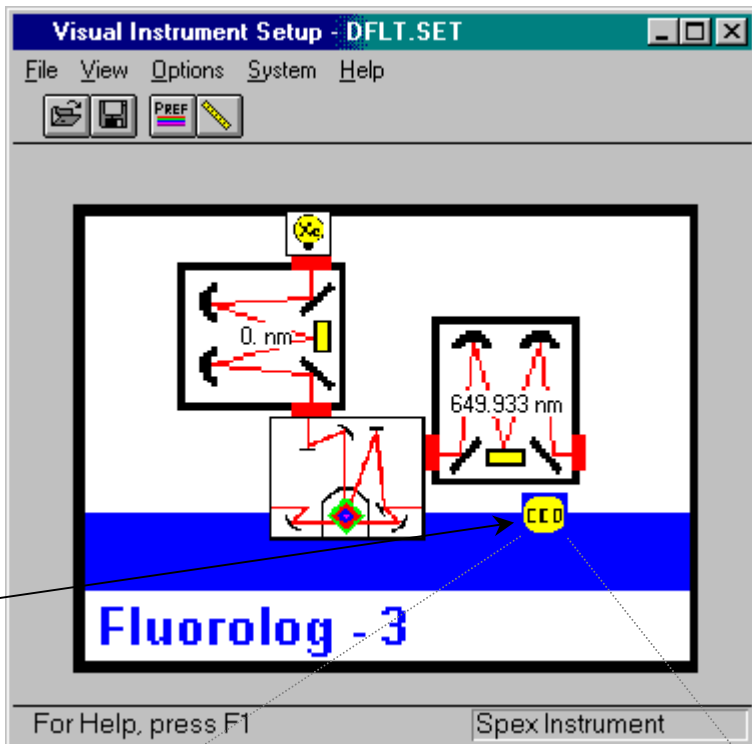

- 1 Click on the CCD icon.
The **Acquisition Channel** window

opens.

- 2 Choose Data Units.

- 3 Choose Gain Level.

- 4 Choose analog-digital conversion.

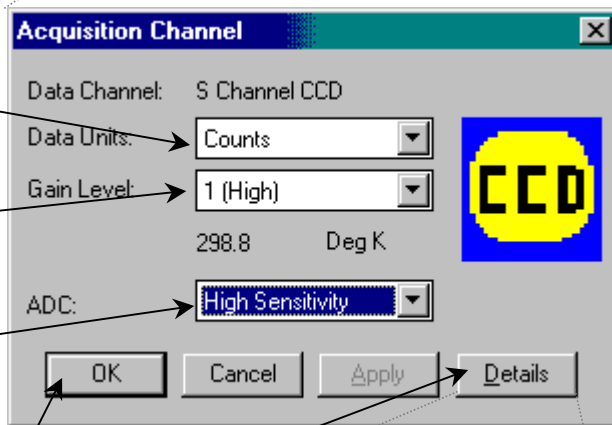

Note: ADC is available only on the CCD-3500.

- 5 Click Details.
The **Acquisition Controller – Details** window opens. Details of the CCD controller are displayed.

- 9 Click OK.
The **Acquisition Controller – Details** window closes.

- 10 Click OK.
The **Acquisition Channel** window closes.

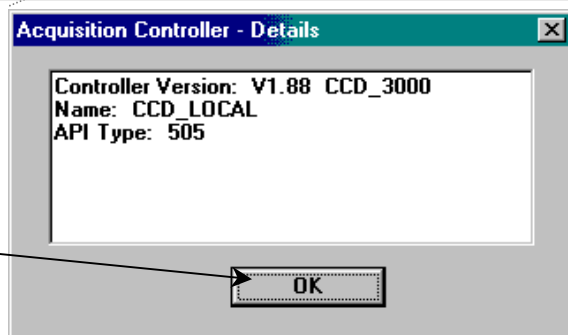

Run Experiment

Within the DataMax main window, CCD experiments using a TRIAX may be performed. To run a CCD acquisition,

1 Choose Collect.

A drop-down menu appears.

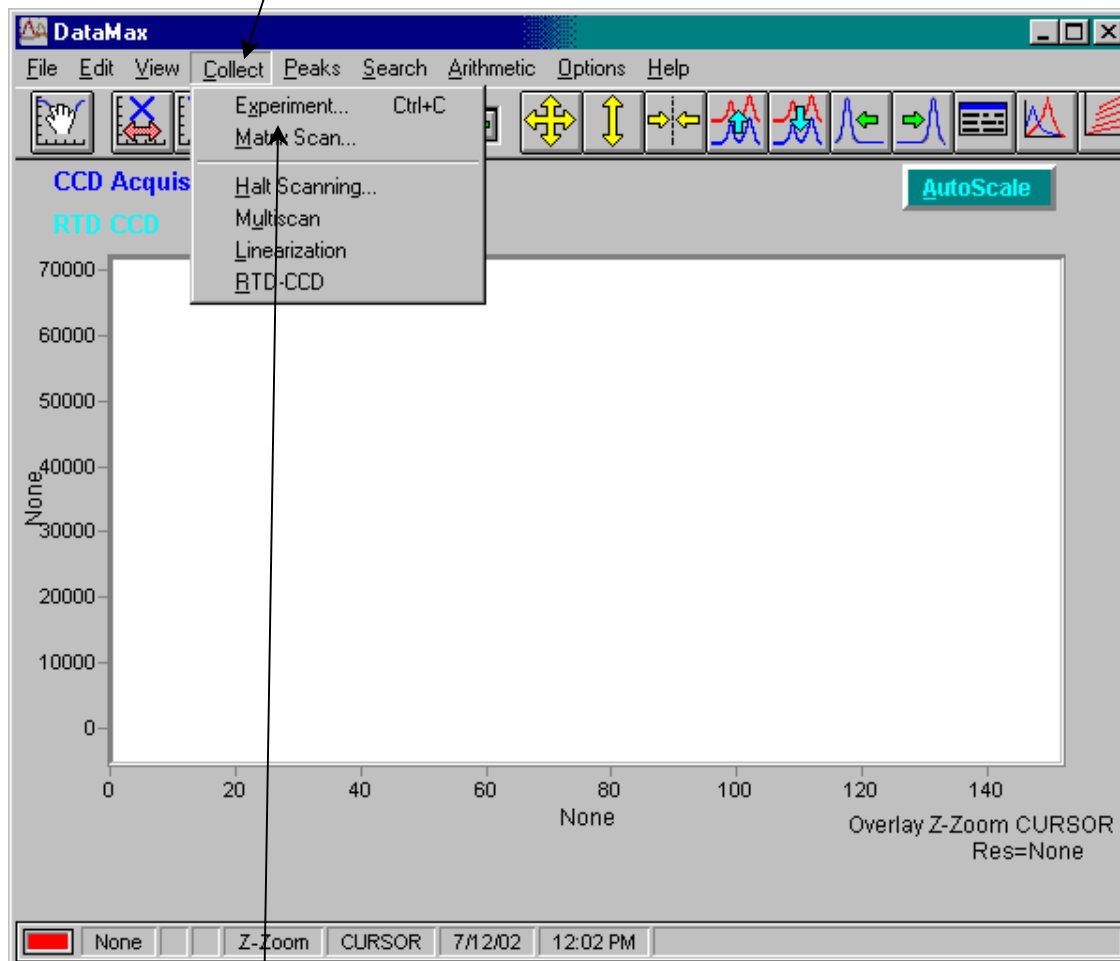

2 Choose Experiment....

The **CCD Acquisition** dialog box opens:

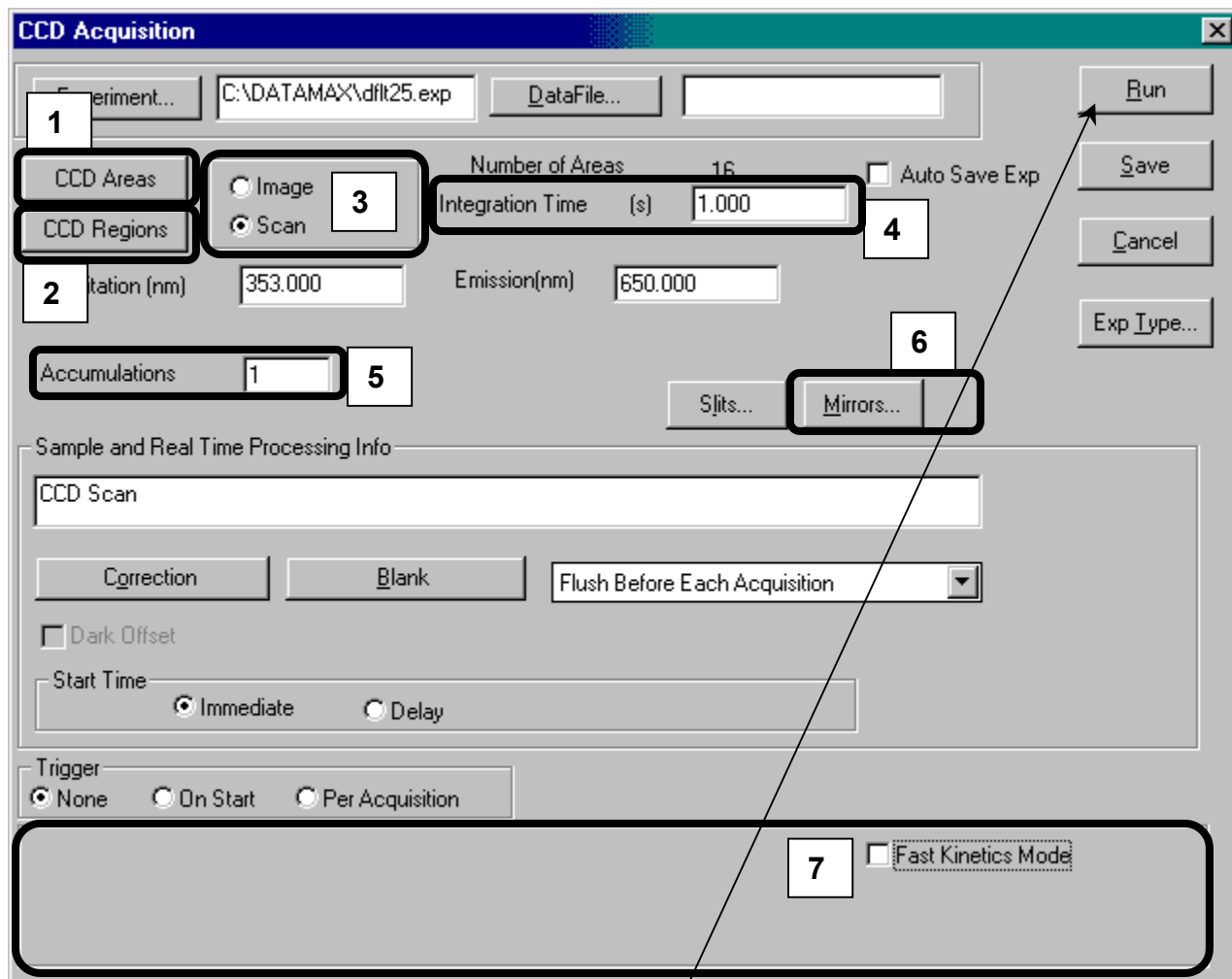

In this dialog box—as with other Experiment Acquisition dialog boxes—the user defines the CCD experiment fully. Several functions specific to the CCD-acquisition type are available, such as:

- 1 CCD Areas
- 2 CCD Regions
- 3 Image and Scan radio buttons
- 4 Integration Time
- 5 Accumulations
- 6 Mirrors...
- 7 Fast Kinetics Mode

These are discussed on the following pages.

3 Complete all required parameters.

4 Click Run.

The **CCD Acquisition** box disappears; the experiment begins.

CCD Areas

A CCD detector can be divided into several data-collection areas, each acting independently. CCD Areas controls how to divide up the CCD chip into multiple detectors.

1 Click CCD Areas.

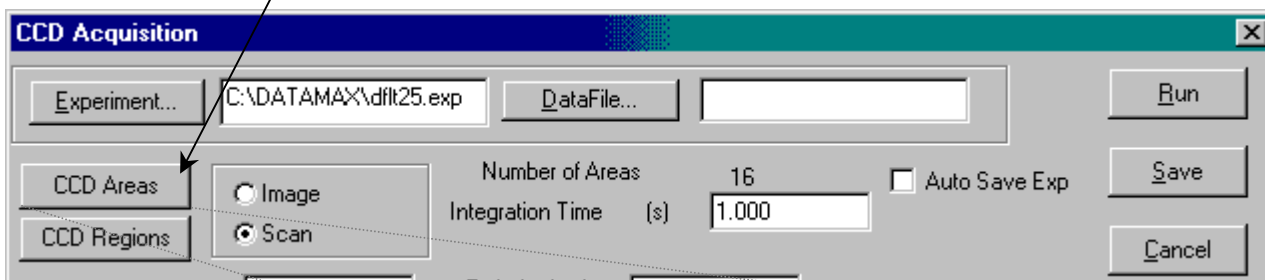

The **Areas List** window appears:

Chip Height and Chip Width

This shows the size of the active area, using a choice of units.

Areas Definitions and Areas Views

These index-card tabs give details about which pixels are active, mathematically (Areas Definitions) and graphically (Areas Views).

Comments:

Unlimited amount of information may be entered, but only the first 80 characters are displayed.

Linearization

Normally, data are taken as pixel number versus intensity. The Linearization checkbox lets the user convert to desired units versus intensity, applying linearization corrections from a correction file created by Jobin Yvon Inc.

Normalize

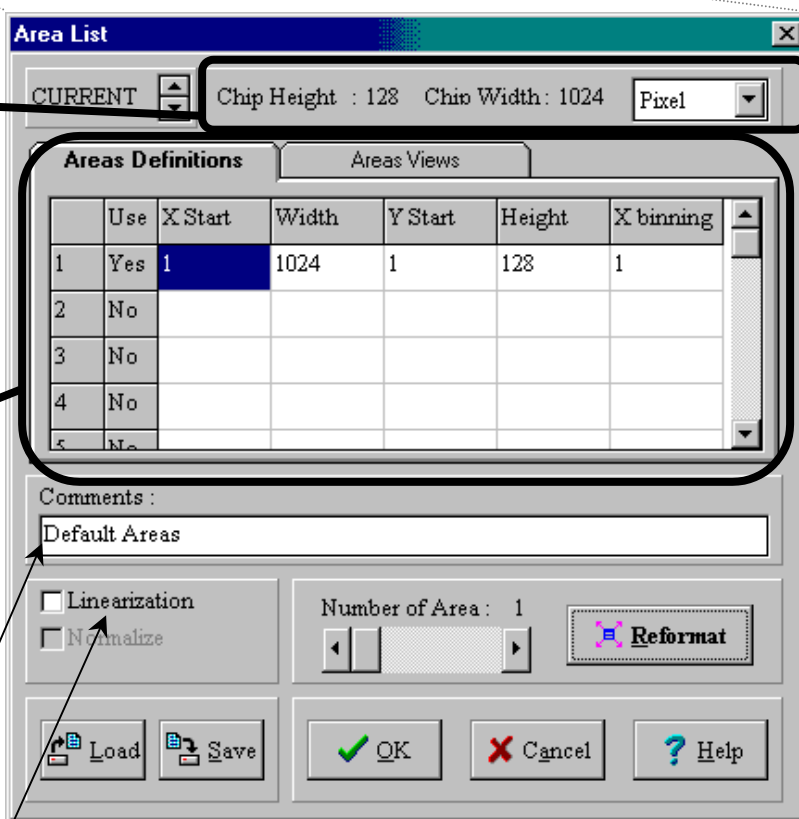

Visible only with two or more active areas, **Normalize** lets the user choose an area as the normalization standard. DataMax performs a **Dark Subtract** on all data, then divides all areas by the normalization standard.

Reformat

Reformat divides the entire CCD chip equally (to within 1 pixel) into the value shown in the **Number of Areas** slider. If **Number of Areas** is 1, then the entire CCD is used as one area. In **Image mode**, only one area is allowed. Changes are shown in the **Areas Definitions**.

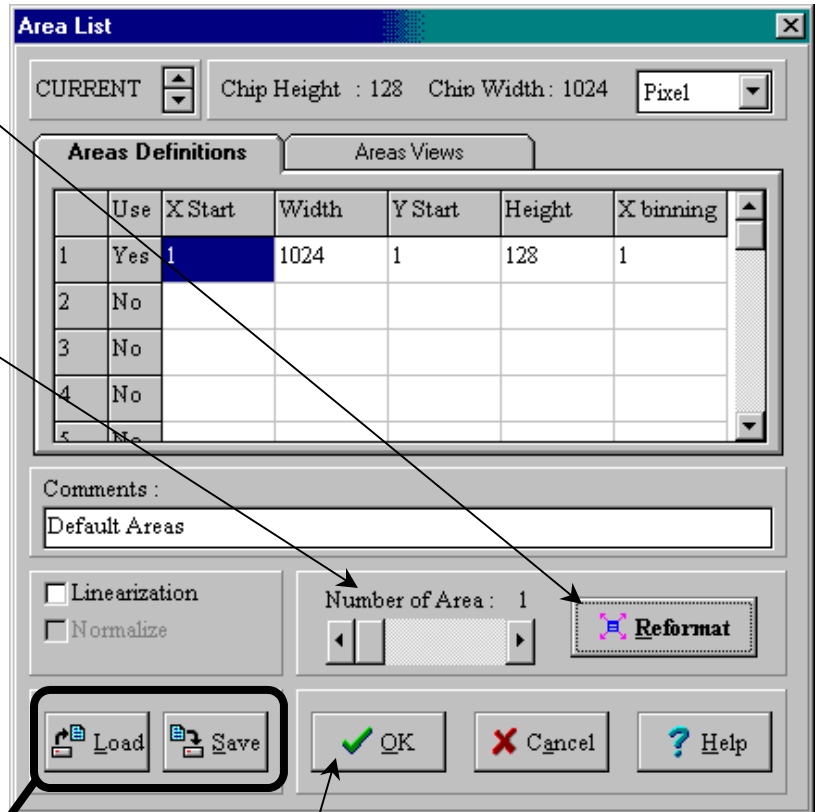

Load and Save

Load and Save custom CCD-area descriptions for later use, with an `.arl` extension.

- 2 When finished, click **OK**.
The **Areas List** window closes.

CCD Regions

In Scan mode, a CCD detector can take “snapshots” of various spectral regions, which can be attached together to create a single complete spectrum. CCD Regions controls how to take and present these “snapshots”.



Warning: Based on the characteristics of multichannel detectors, discontinuities appear when various spectral regions are attached together in Scan mode.

1 Click CCD Regions.

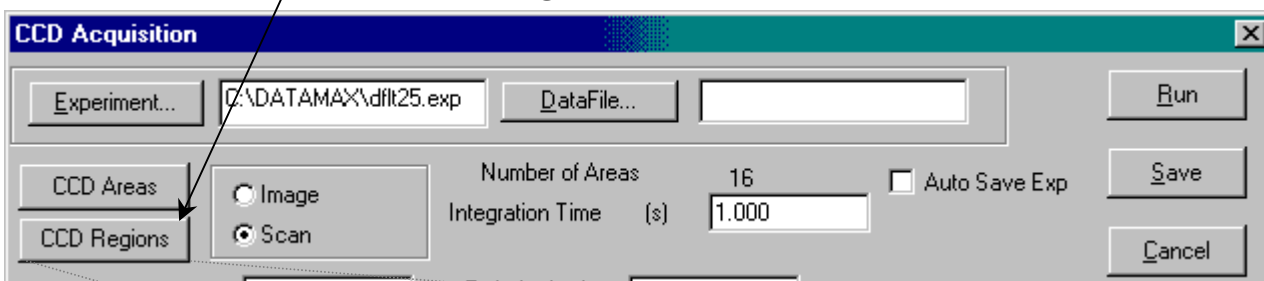

The Acquisition Setup dialog box opens:

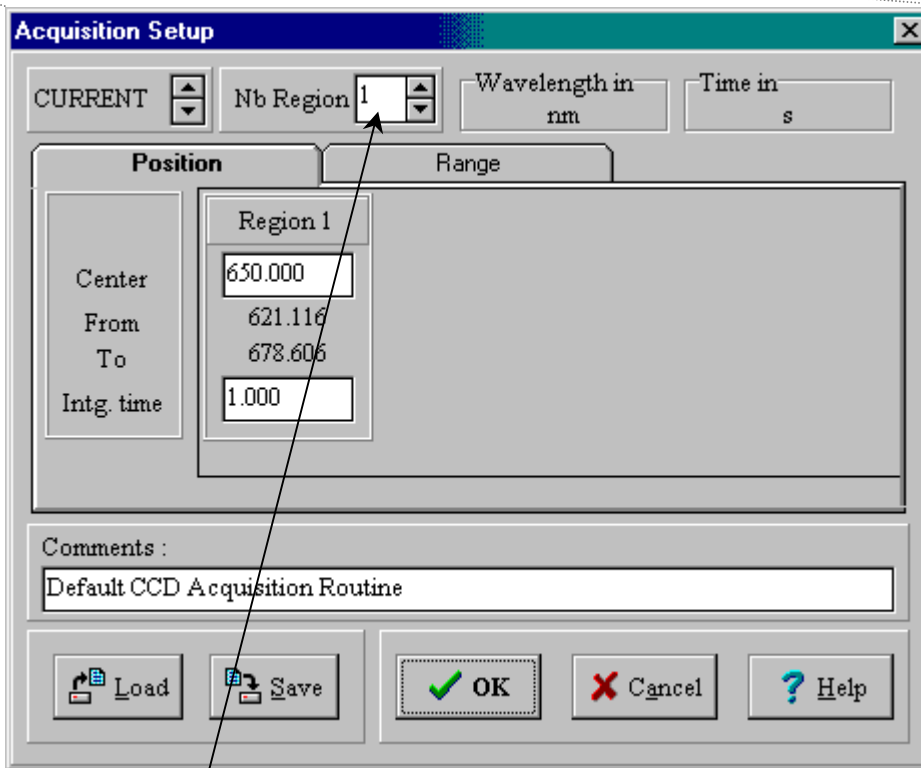

2 Enter the number of regions to scan.

Multiple CCD areas may be defined independently. The Nb region field shows which area is being set. Extra data-entry fields appear, based on the desired number of regions.

Two methods specify how to acquire data: the **Position** index card, setting the central wavelength, and the **Range** index card, setting the region on the CCD detector.

Position method

3 Click on the Position index-card tab.

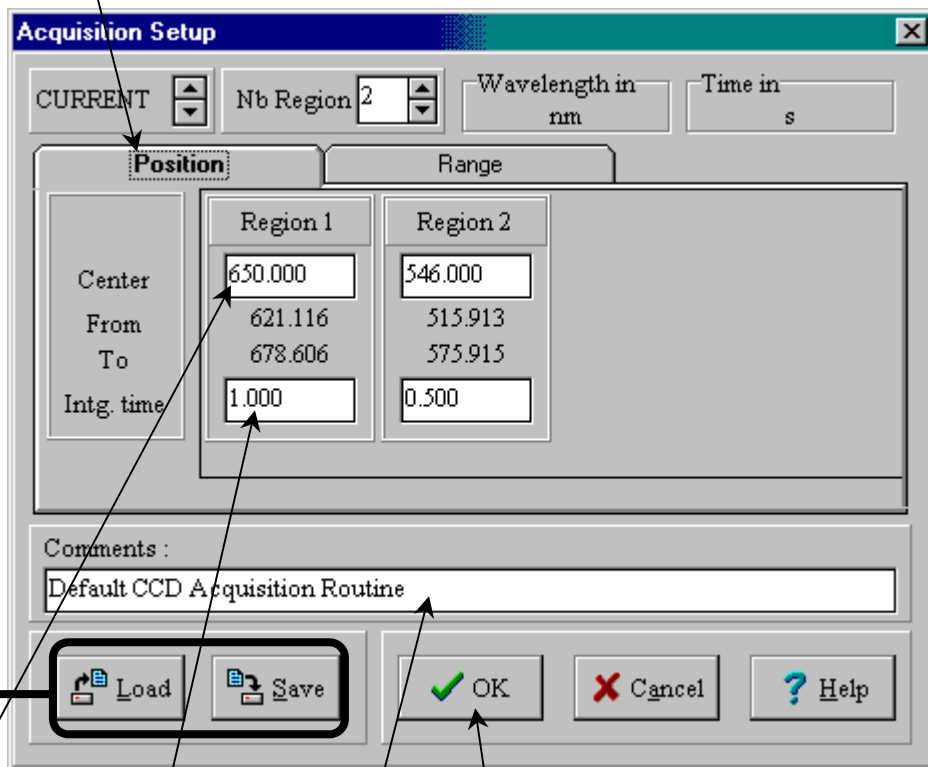

4 Enter the Center wavelength, in nm, for each region.

The range shown, in nm, depends on the chip size, the TRIAX model, and the grating's groove density.

5 Enter the desired integration time, in s, next to the Int. Time field for each region.

6 Enter a comment.

Only the first 80 characters are displayed.

Load and Save

Load and Save custom CCD-area descriptions for later use, with an `.arl` extension.

7 When finished, click OK to close the **Acquisition Setup** window.

Range method

- 3 Click on the Range index-card tab.
- 4 Enter the starting wavelength in From.
- 5 Enter the ending wavelength in To.
- 6 Enter the integration time in Intg. time.

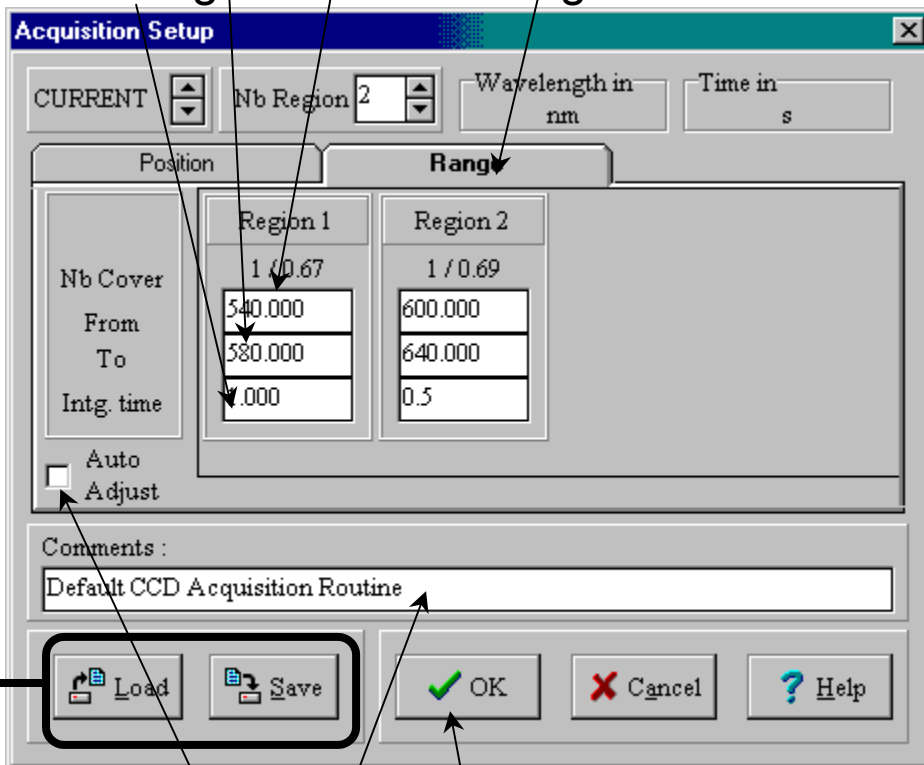

- 7 For piecing together several “snapshots” with automatic baseline matching, click Auto Adjust. The Nb Cover field changes depending on the grating, TRIAX, and CCD chip.

- 8 Enter a comment.
Only the first 80 characters are displayed.

Load and Save

Load and Save custom CCD-area descriptions for later use, with an .arl extension.

- 9 When finished, click OK to close the **Acquisition Setup** window.

Image and Scan

These radio buttons choose between two detection formats:
Using the CCD chip as a two-dimensional detector (**Image**), or

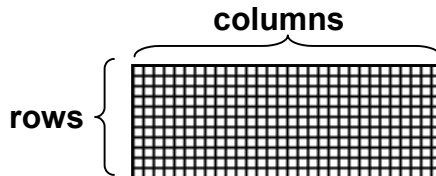

Binning columns of pixels together to create a one-dimensional detector (**Scan**) for recording standard spectra.

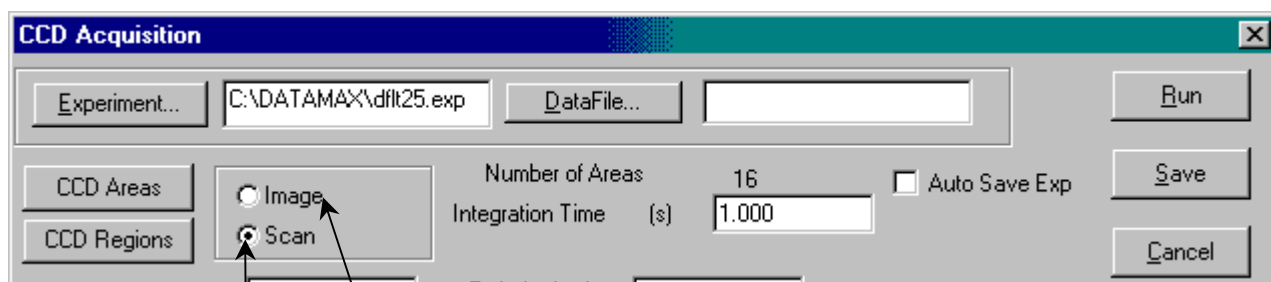
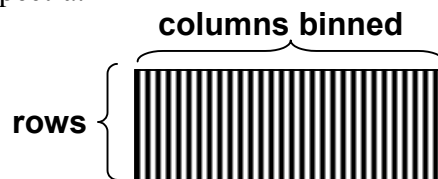

For 2-D detection,

1 Click Image.

For 1-D detection,

1 Click Scan.

When one of these radio buttons is chosen, the **CCD Acquisition** window may adjust some of the data-entry fields available.

Integration Time

This is the amount of time that the CCD chip is exposed to the sample's luminescence.

CCD Acquisition

Experiment... C:\DATAMAX\dflt25.exp DataFile... Run

CCD Areas Image Scan Number of Areas 16 Auto Save Exp Save

CCD Regions Integration Time (s) 1.000 Cancel

Excitation (nm) 353.000 Emission(nm) 650.000 Exp_Type...

Accumulations 1 Slits... Mirrors...

Sample and Real Time Processing Info

CCD Scan

Correction Blank Flush Before Each Acquisition

Dark Offset

Start Time Immediate Delay

Trigger None On Start Per Acquisition

Fast Kinetics Mode

- 1 Enter the Integration Time, in s, in the data-entry field.
- 2 Click on another data-entry field to finalize the value.

Accumulations

An “accumulation” is one exposure to the luminescence for a particular active CCD area. Accumulations are added together if more than one accumulation is specified.

The screenshot shows the 'CCD Acquisition' dialog box. The 'Accumulations' field is highlighted with a red box, and a red arrow points to it from the text below. The dialog box contains the following fields and controls:

- Experiment...: C:\DATAMAX\dfkt25.exp
- DataFile...: [Empty]
- Run: [Button]
- CCD Areas: [Button]
- CCD Regions: [Button]
- Image:
- Scan:
- Number of Areas: 16
- Integration Time (s): 1.000
- Auto Save Exp:
- Save: [Button]
- Cancel: [Button]
- Exp Type...: [Button]
- Excitation (nm): 353.000
- Emission(nm): 650.000
- Accumulations: 1
- Splits...: [Button]
- Mirrors...: [Button]
- Sample and Real Time Processing Info:
 - CCD Scan: [Text Field]
 - Correction: [Button]
 - Blank: [Button]
 - Flush Before Each Acquisition: [Dropdown]
 - Dark Offset:
 - Start Time:
 - Immediate:
 - Delay:
- Trigger:
 - None:
 - On Start:
 - Per Acquisition:
- Fast Kinetics Mode:

- 1 Enter the desired number of accumulations in the data-entry field.
- 2 Click on another data-entry field to finalize the value.

Mirrors...

At present, this button is inactive in DataMax.

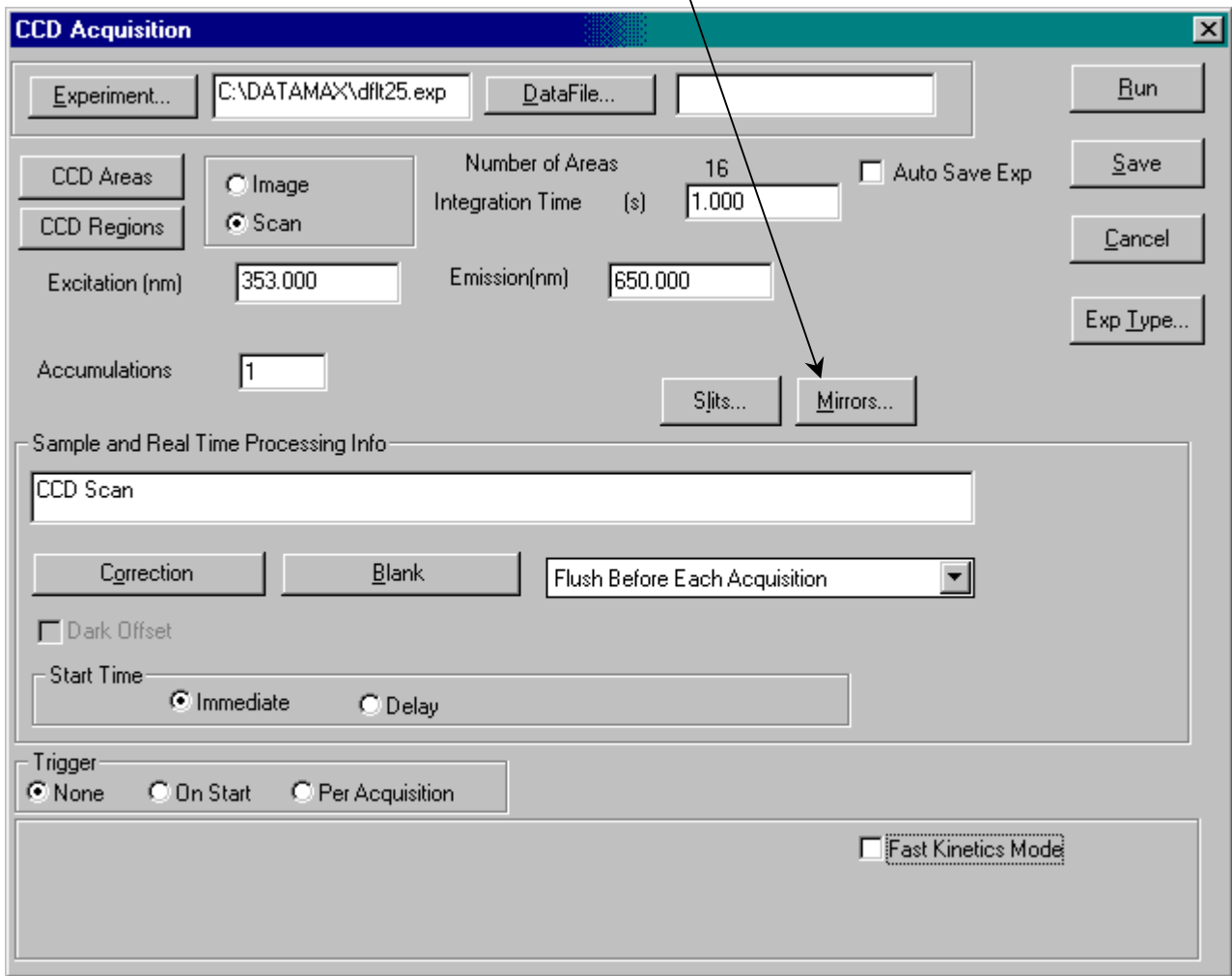

Correction

The Correction button is useful only when working with a PMT.

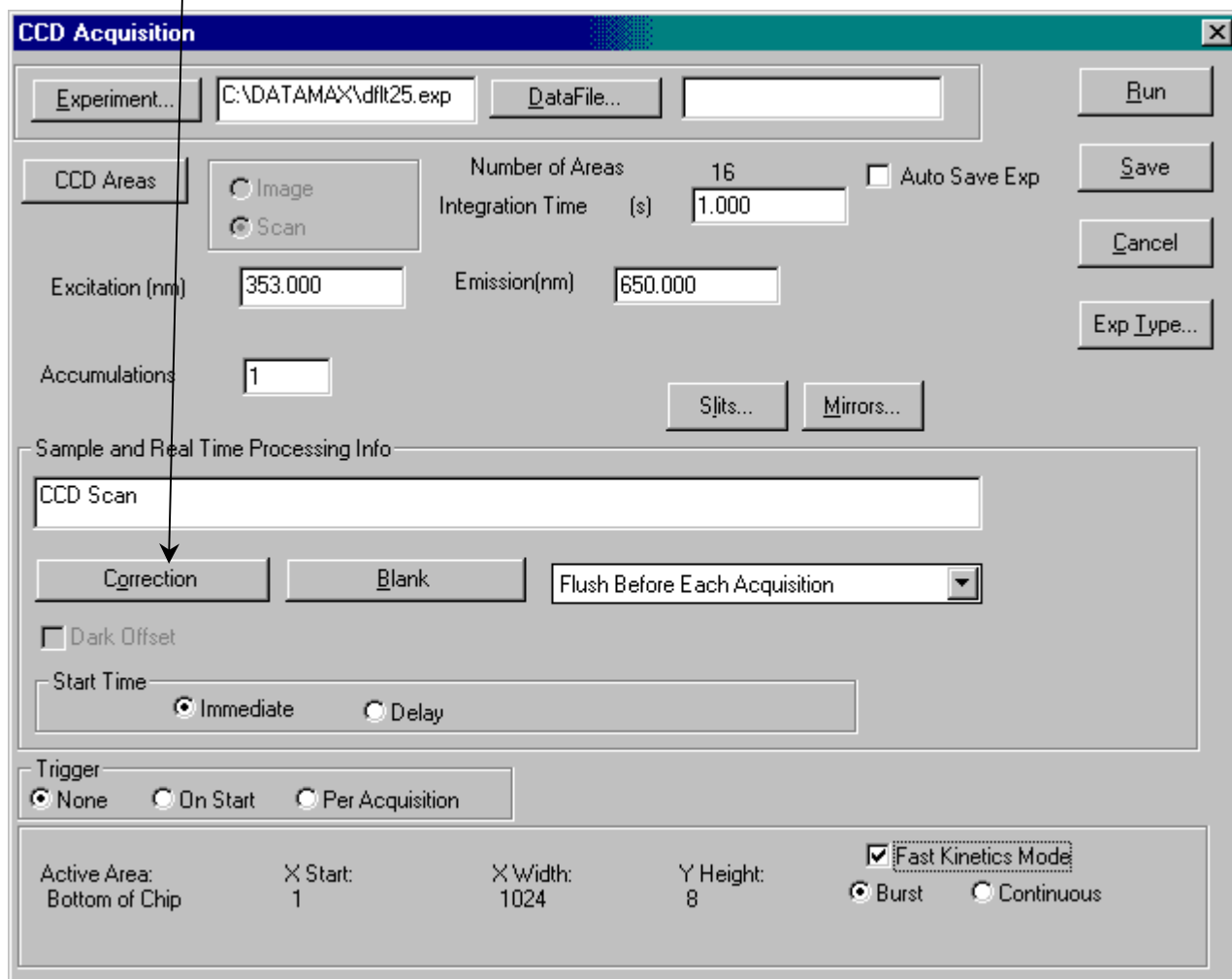

The screenshot shows the 'CCD Acquisition' dialog box with the following settings:

- Experiment...: C:\DATAMAX\dflt25.exp
- DataFile...: [Empty]
- Run: [Button]
- CCD Areas: Image, Scan
- Number of Areas: 16
- Integration Time (s): 1.000
- Auto Save Exp:
- Save: [Button]
- Excitation (nm): 353.000
- Emission(nm): 650.000
- Cancel: [Button]
- Accumulations: 1
- Slits...: [Button]
- Mirrors...: [Button]
- Exp Type...: [Button]
- Sample and Real Time Processing Info:
 - CCD Scan: [Text Box]
 - Correction: [Button]
 - Blank: [Button]
 - Flush Before Each Acquisition: [Dropdown]
 - Dark Offset:
 - Start Time: Immediate, Delay
- Trigger: None, On Start, Per Acquisition
- Active Area: Bottom of Chip
- X Start: 1
- X Width: 1024
- Y Height: 8
- Fast Kinetics Mode:
- Burst: Continuous:



Warning: Correction factors pertain only to the photomultiplier tube or other single-point detector, and NOT to a 2-dimensional CCD detector. Therefore, corrections to raw data cannot be made in CCD mode.

Fast Kinetics Mode

Fast Kinetics Mode is a special high-speed data-acquisition mode that uses only a portion of the CCD (top or bottom) as the active area. The **Fast Kinetics Mode** checkbox contains hidden data-entry fields.

1 Check the Fast Kinetics Mode checkbox.

When checked, new fields appear, while others disappear:

The screenshot shows the 'CCD Acquisition' window with the following settings:

- Experiment: C:\DATAMAX\dfkt25.exp
- Number of Areas: 16
- Integration Time (s): 1.000
- Excitation (nm): 353.000
- Emission (nm): 650.000
- Accumulations: 1
- Sample and Real Time Processing Info: CCD Scan
- Flush Before Each Acquisition: [Dropdown]
- Start Time: Immediate
- Trigger: None
- Active Area: Bottom of Chip
- X Start: 1, X Width: 1024, Y Height: 8
- Fast Kinetics Mode
- Burst, Continuous

2 Choose the Burst or Continuous radio buttons.

- **Burst** means one rapid exposure. With **Burst**, the **CCD Acquisition** window appears as shown above. **Burst** mode exposes the top edge of the CCD to the luminescence, while the remainder of the chip serves as a temporary storage area until the data are read.
- **Continuous** means continue to retake an exposure, spaced by a time increment. This is a slower method of acquisition, using the bottom edge of the chip. With **Continuous**, the **CCD Acquisition** window appears as shown below:

In Continuous mode,

- a Choose the number of Accumulations.
 - b Set the Integration Time.
 - c Choose the Time Increment from the start of one exposure to the start of the next exposure.
 - d Set the Enable Int. Shutter Move checkbox. If checked, the CCD shutter opens and closes at each accumulation. If unchecked, the CCD shutter opens at the start of the experiment, and closes at the end.
 - e Decide upon a Last Read Out Time.
- 3 Set all appropriate parameters.
 - 4 Click Run.
The experiment begins.

Flush

The Flush option can remove all residual charges from the CCD chip before data acquisition. The drop-down menu contains three choices:

- Flush Before Each Acquisition Clear out all charges before an accumulation.
- No Flush Charges are not removed before an accumulation. This is faster, but background noise may increase between acquisitions. For multiple scans, the first acquisition may have a higher background-noise level than later ones.
- Flush Before First Scan The charges are removed only before the first scan.

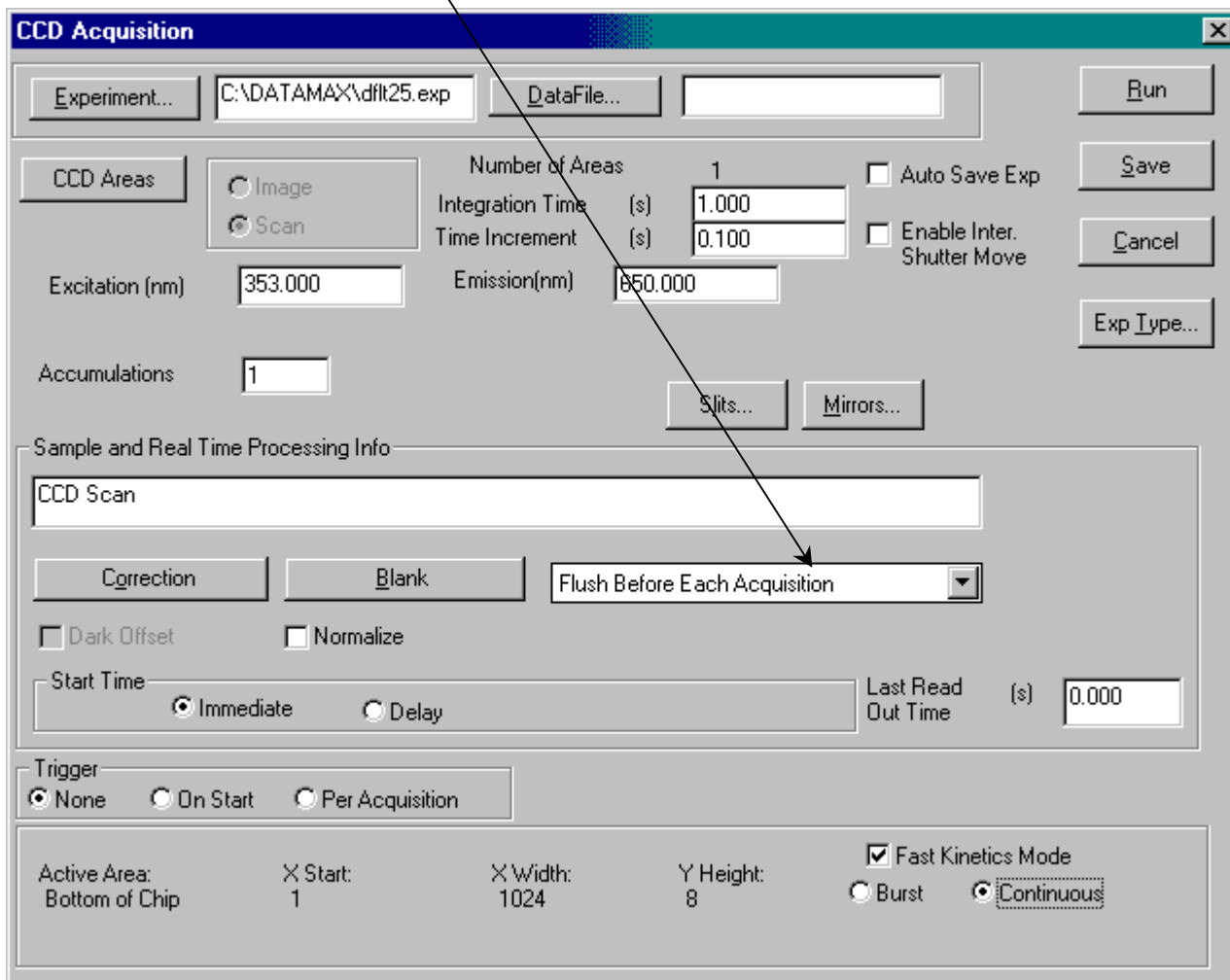

Linearization

Use this function to re-align the TRIAX if the peaks' wavelengths are correctly assigned near the center of the CCD, but are incorrect near the edges.

1 Choose Collect.

A drop-down menu appears.

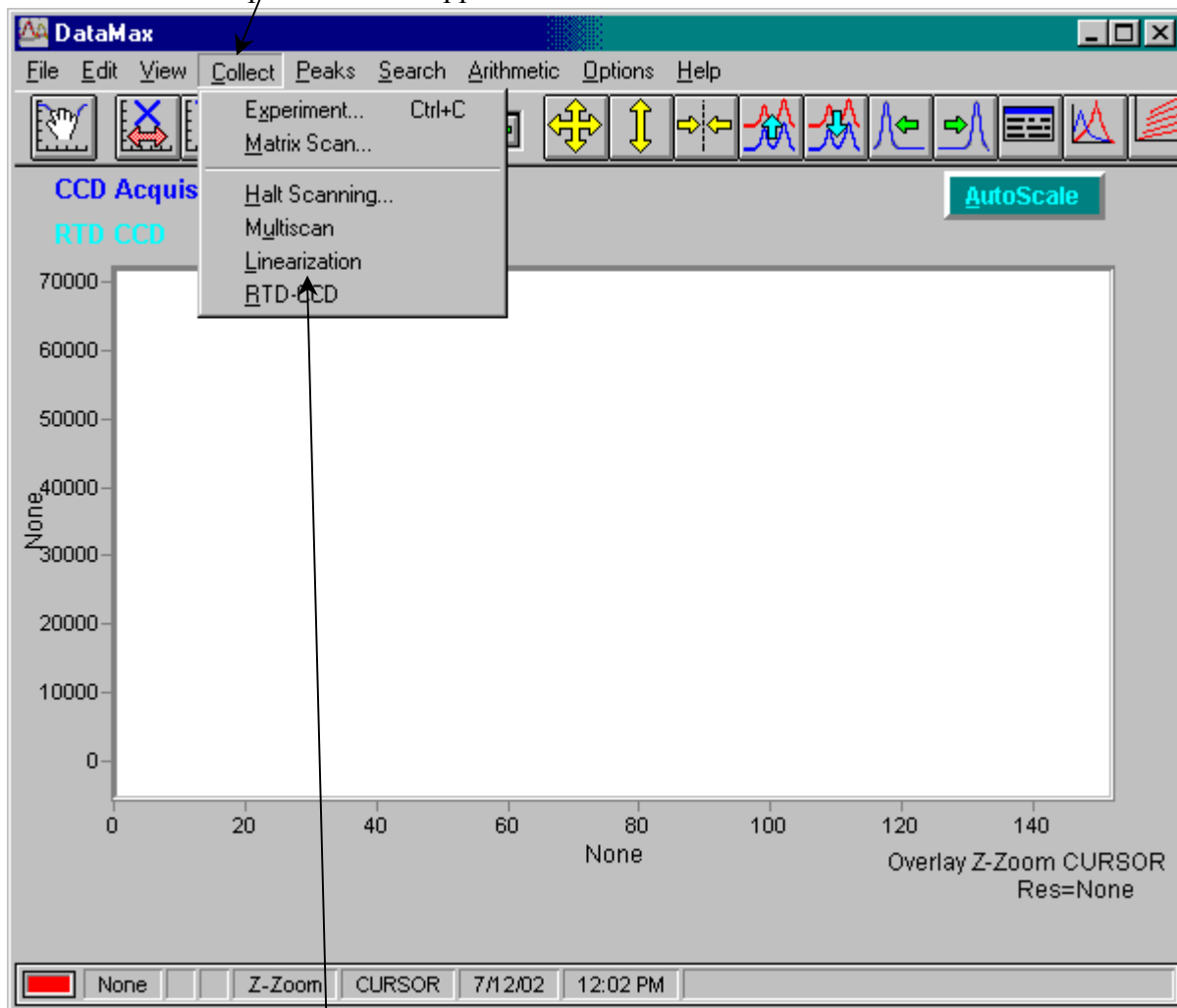

2 Choose Linearization.

The **Linearization Parameters** window opens.



Note: Your parameters may differ from those shown.

3 Enter the desired parameters, or have DataMax calculate them for you.

If you choose to enter them,

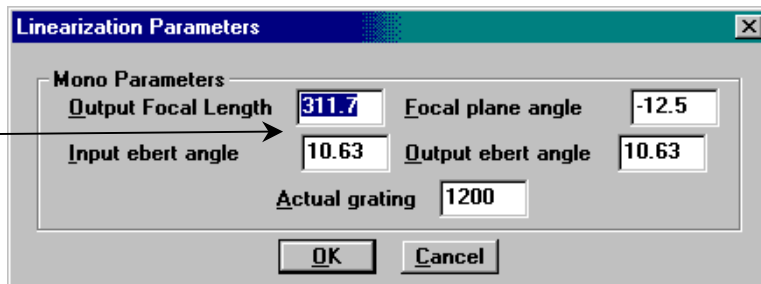

- a Do so.
- b Click OK.

If you choose to have DataMax calculate them,

- a Click OK.

The **Linearization Parameters** window closes, and the **Linearization Procedure** dialog box appears.

4 Choose the desired checkbox:

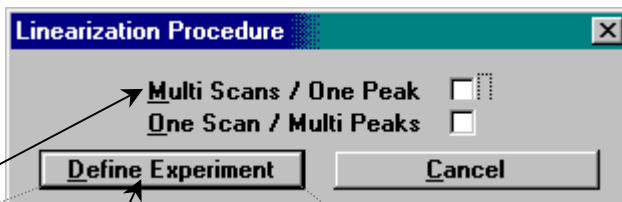

- Multi Scans/One Peak, for a single wavelength from a source, such as the 547.074-nm line from a Hg lamp. This takes 5 spectra of the line displaced across the chip, and requires a motorized spectrometer.

- a Click Define Experiment.
The **CCD Acquisition** dialog box appears.

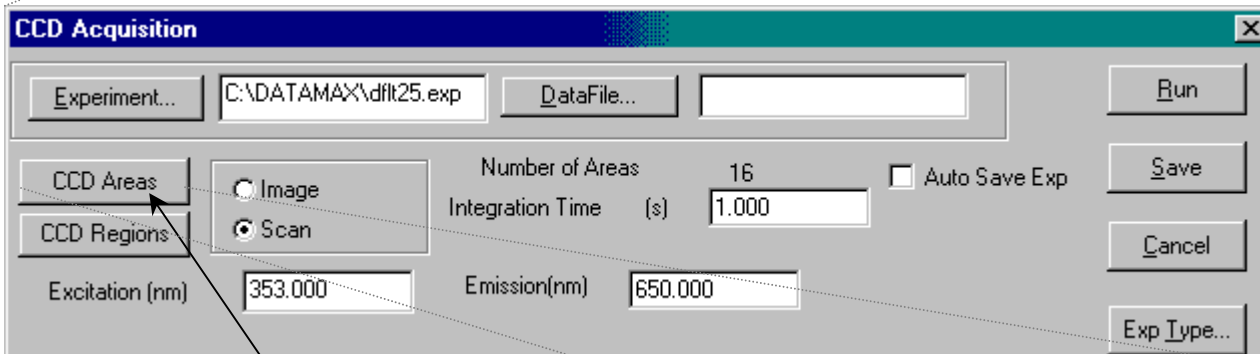

- b Click CCD Areas.

The **Area List** window opens.

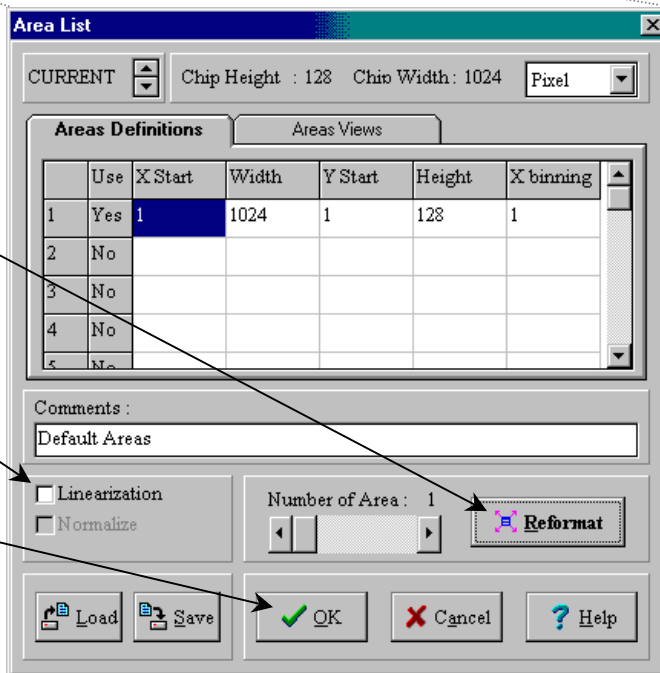

- c Click Reformat, to use the entire chip.

- d De-activate the Linearization checkbox.

- e Click OK.
The **Area List** window closes.

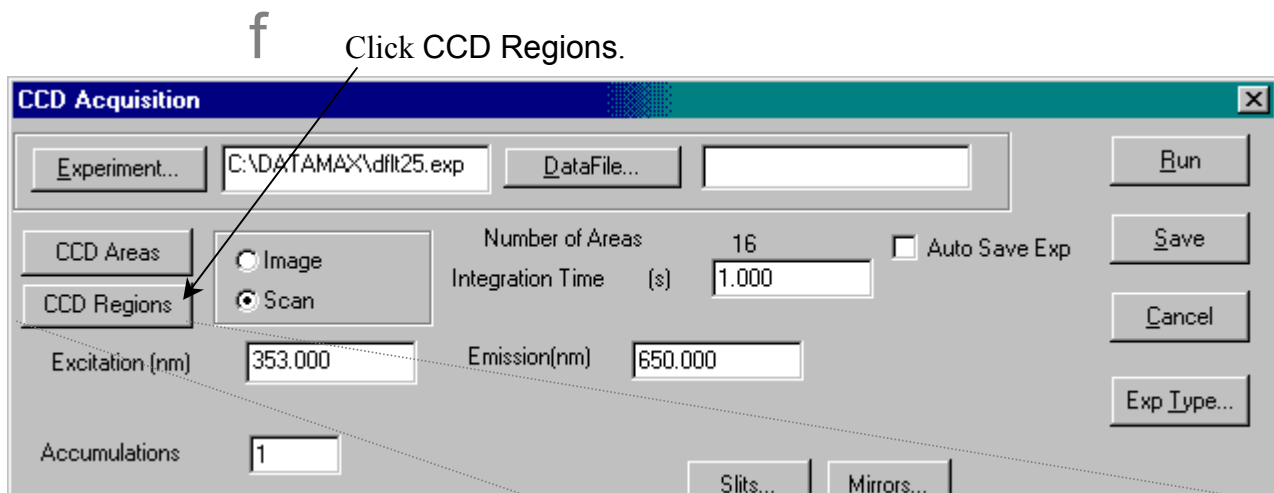

f Click CCD Regions.

The **Acquisition Setup** window opens.

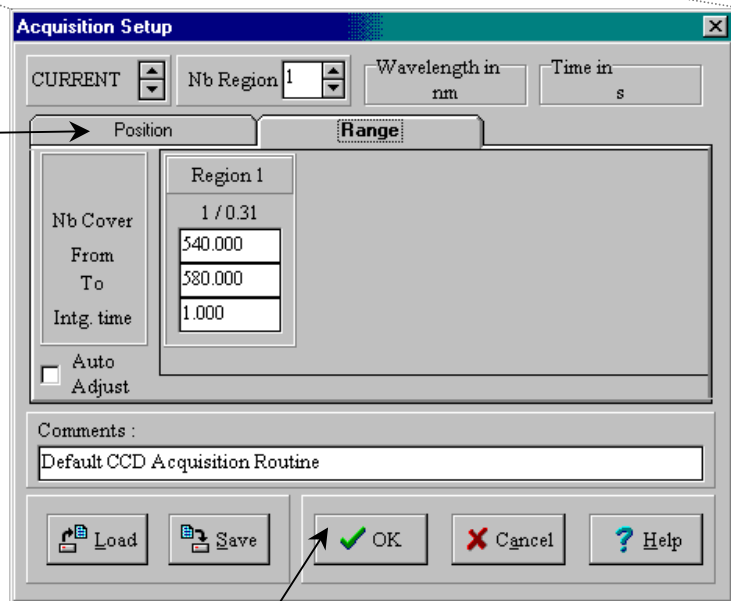

g Choose the **Position** index-card tab.

Five different spectra are required. The following example uses a CCD that is 2000 pixels wide × 800 pixels high, with a Hg line at 546.074 nm.

h Set Nb Region to 1.

i Set the Center to 546.074 nm, and press Enter.

j Calculate the increment $i = \frac{\text{To} - \text{From}}{5}$, to give 5 positions using the maximum amount of the chip in linearization.

k Set Nb Regions to 5.

l Set the first region's From = $1.05 \times i$.

m Set the second region's Center₂ = Center of region 1 + i .

n Repeat steps 12 and 13 until all 5 regions are assigned.

o Click OK.

The **Acquisition Setup** window closes. In the **CCD Acquisition** dialog box,

p Enter a file name.

- q Enter the integration time.
- r Enter other required parameters, e.g., slit widths.
- s Click Run.

- One Scan/Multi Peaks, for one source with at least five known lines within the CCD's area. This is done with fixed-grating spectrographs and movable grating systems not attached to the system.

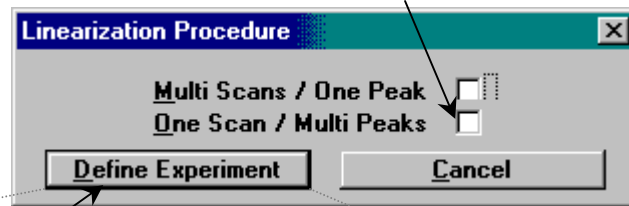

- a Click Define Experiment. The **CCD Acquisition** box appears.

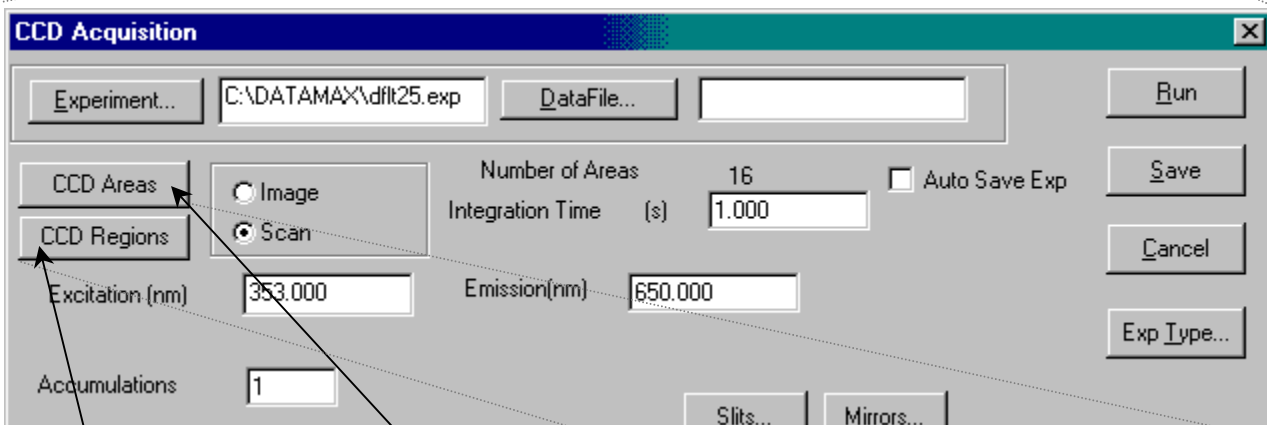

- b Click CCD Areas. The **Area List** window opens.

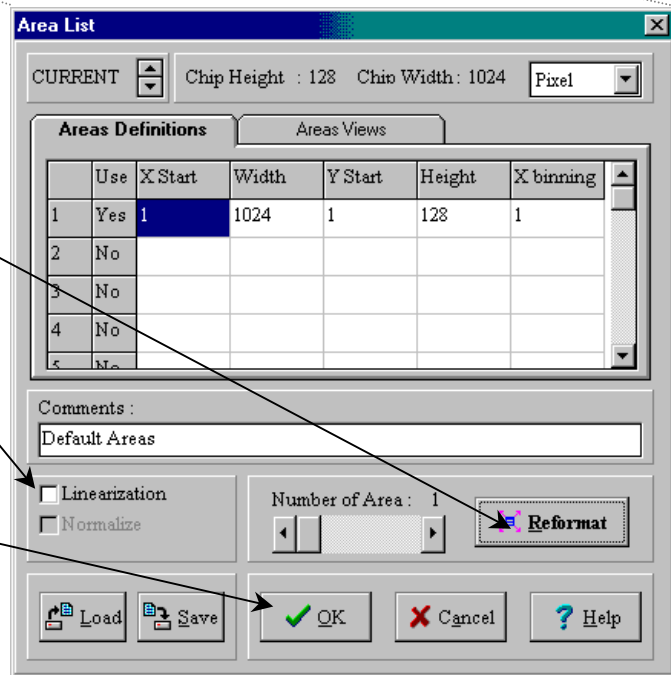

- c Click Reformat, to use the entire chip.

- d De-activate the Linearization checkbox.

- e Click OK. The **Area List** dialog box closes.

- f Click CCD Regions. The **Acquisition Setup** dialog box appears.

g Choose the **Position** index-card tab.

The spectrum must contain five known peaks on different areas of the CCD chip.

h Set **Nb Region** to 1.

i Click **OK**.
The **Acquisition Setup** window closes.
In the **CCD Acquisition** dialog box,

j Enter a file name.

k Enter the integration time.

l Enter other required parameters, e.g., slit widths.

m Click **Run**.

If defined correctly for either technique, DataMax collects the spectrum. The **Select Calibration Peak** window appears.

A dialog box appears requesting the calibration wavelengths (for Multi Scans) or verification (for One Scan). When enough peaks have been selected for calibration, the **Calc** button appears:

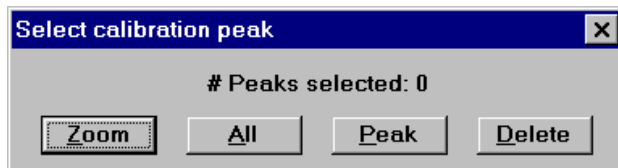
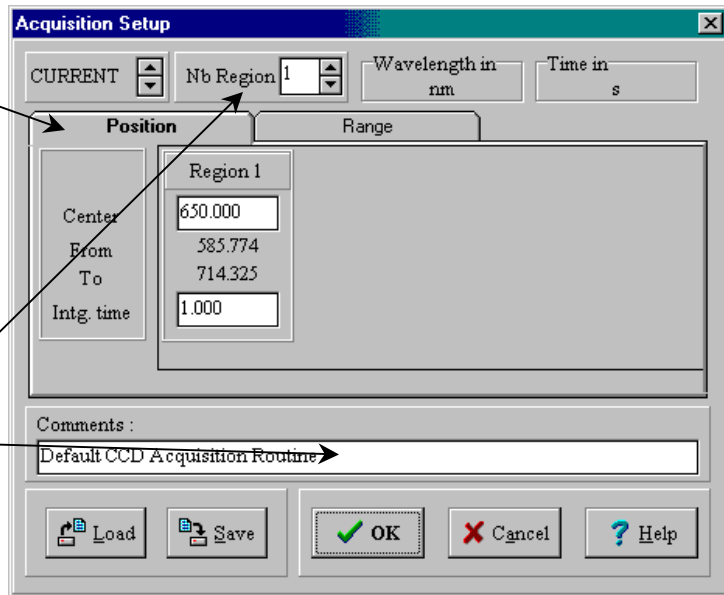

5 Select **Calc** if correct; select

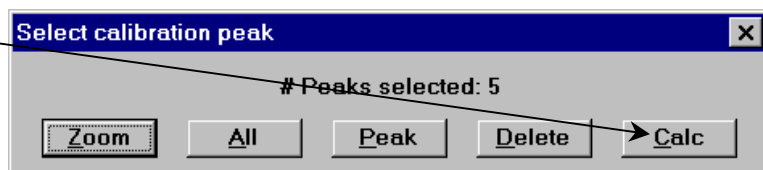

Correct to adjust the values.

DataMax calculates new parameters.

6 Close and exit all DataMax programs.

7 Restart DataMax to cause the changes to take effect.

Autoscaling the display

AutoScale is always on, and cannot be switched off

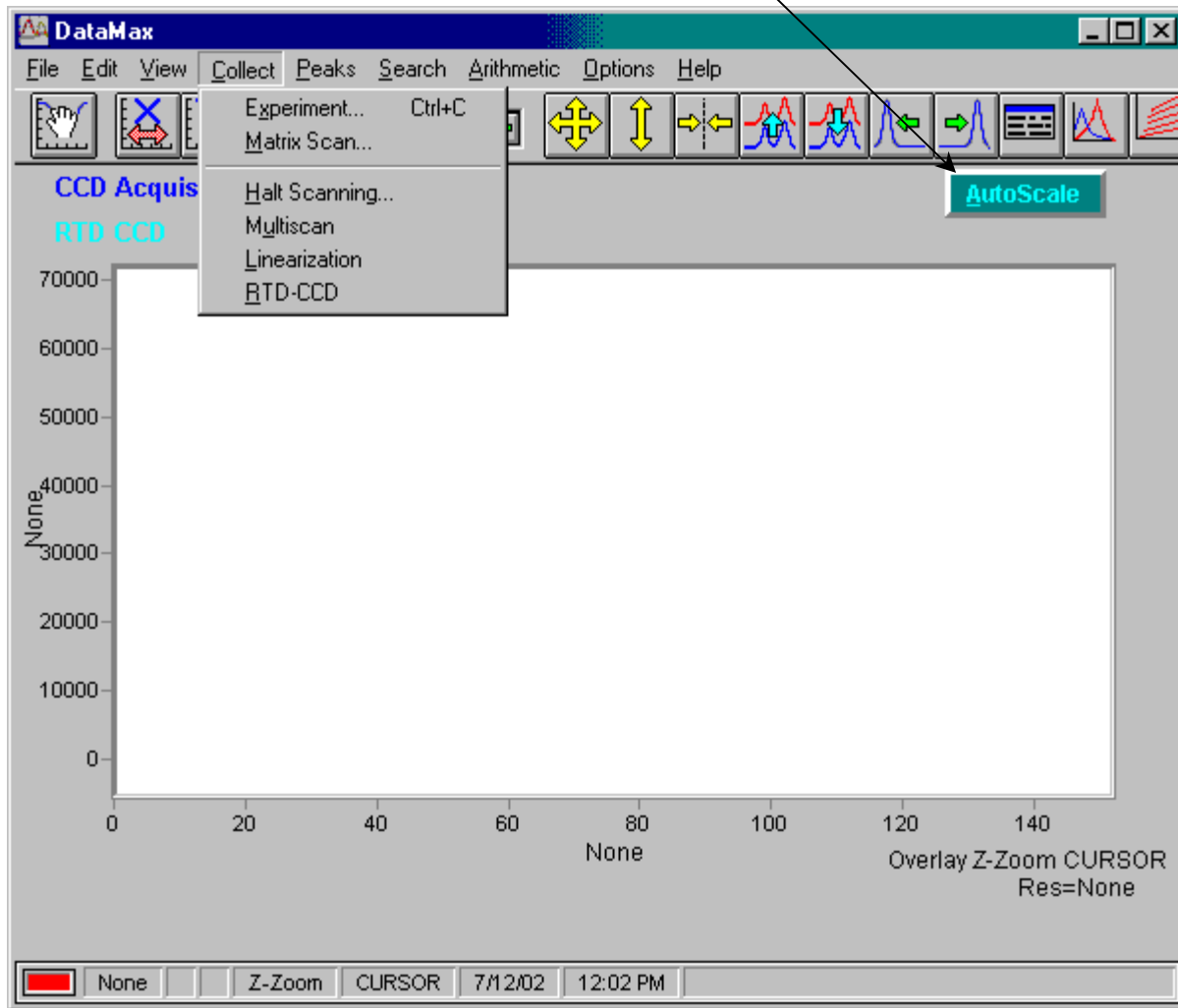

Real Time Display

Unlike typical systems, **Real Time Display** with a TRIAX and CCD must be used with the **Run Experiment** window open simultaneously. The **Real Time Display** is used to optimize the CCD detector and TRIAX settings for the best experimental results.

To do a CCD acquisition in the **Real Time Display**,

- 1 In **Instrument Control Center**, click the **Run Experiment** button.

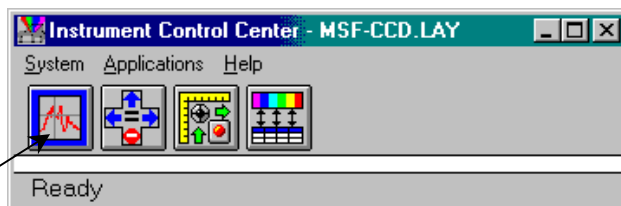

The DataMax main window appears.

- 2 Choose **Collect**.
- 3 A drop-down menu appears.

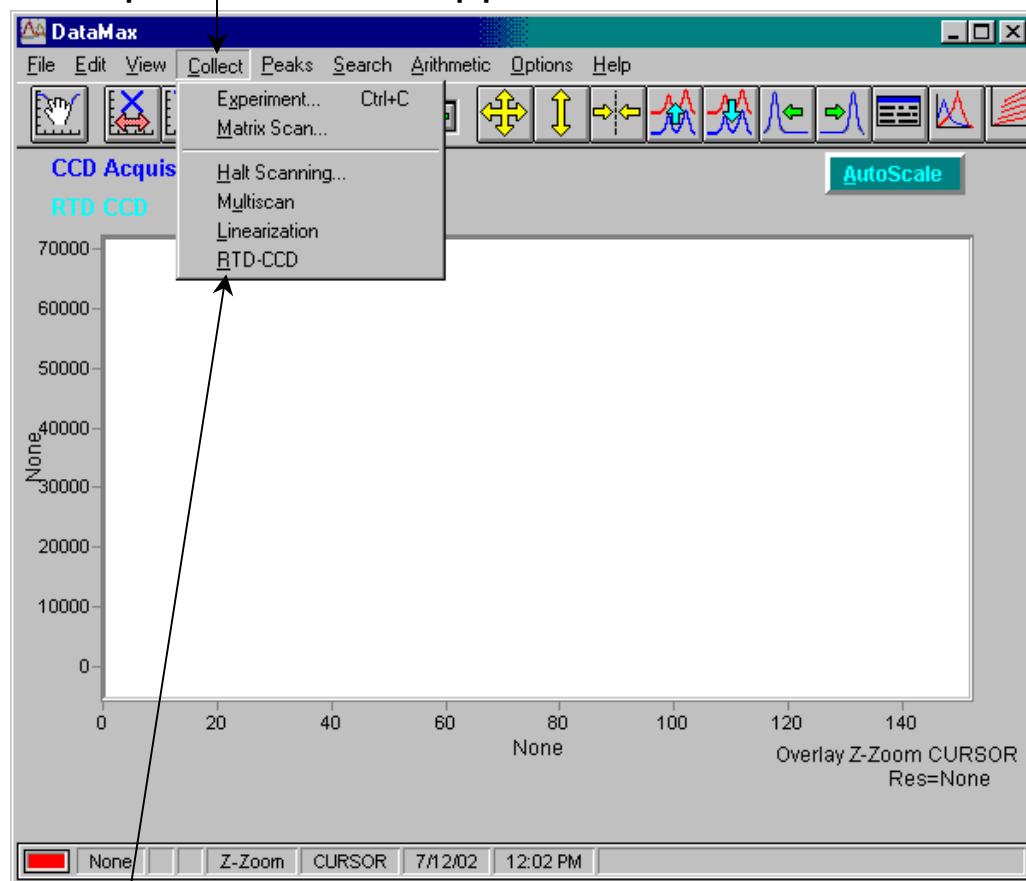

- 4 Choose **RTD-CCD**.
The **Real Time Display** opens.



Note: The **Counts** window does not appear in **Real Time Display** with a **CCD** detector, because the system is collecting data over many pixels, not reporting a single number.

The Toolbar

When a single-point detector (e.g., PMT, InGaAs, IR, etc.) is attached to a TRIAX and activated in the correct layout, an HV button appears in the **Toolbar**.

The Intensity window

The **Intensity** window is used *only* for a single-point detector (e.g., PMT, InGaAs, IR, etc.).

The Slits window

Note the following terms used in the **Slits** window:

- Front = axial slit
- Side = lateral slit



Note: The exit slit-width parameter is valid only for PMT users. For CCD detectors, there is no slit at the exit of the TRIAX, so any displayed settings are superfluous.



Note: Some slits cannot be set in **Real Time Display**.

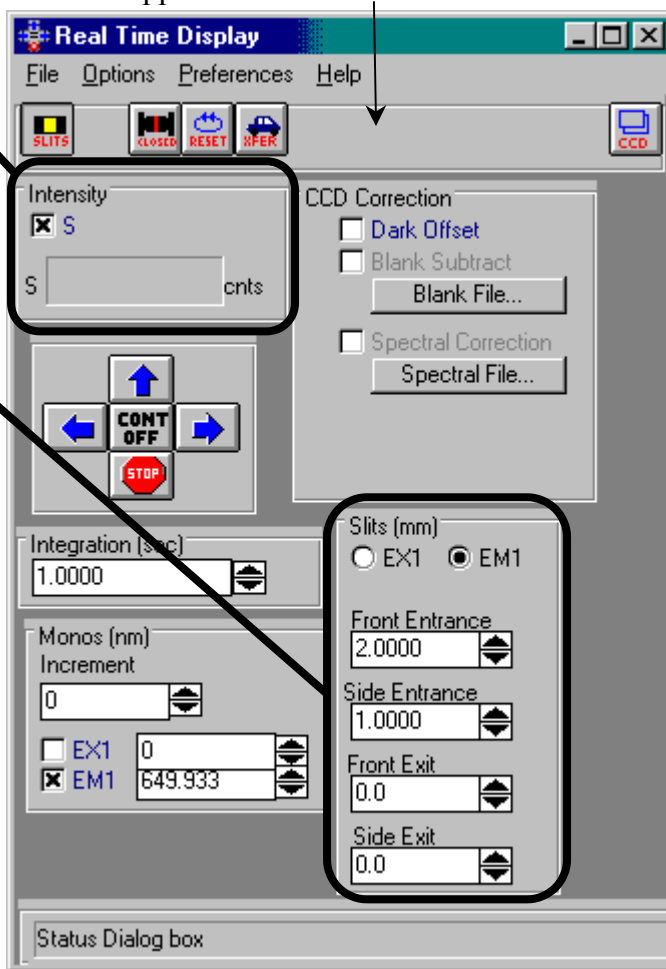

CCD button

The CCD button provides information about the CCD chip.

1 Click CCD.

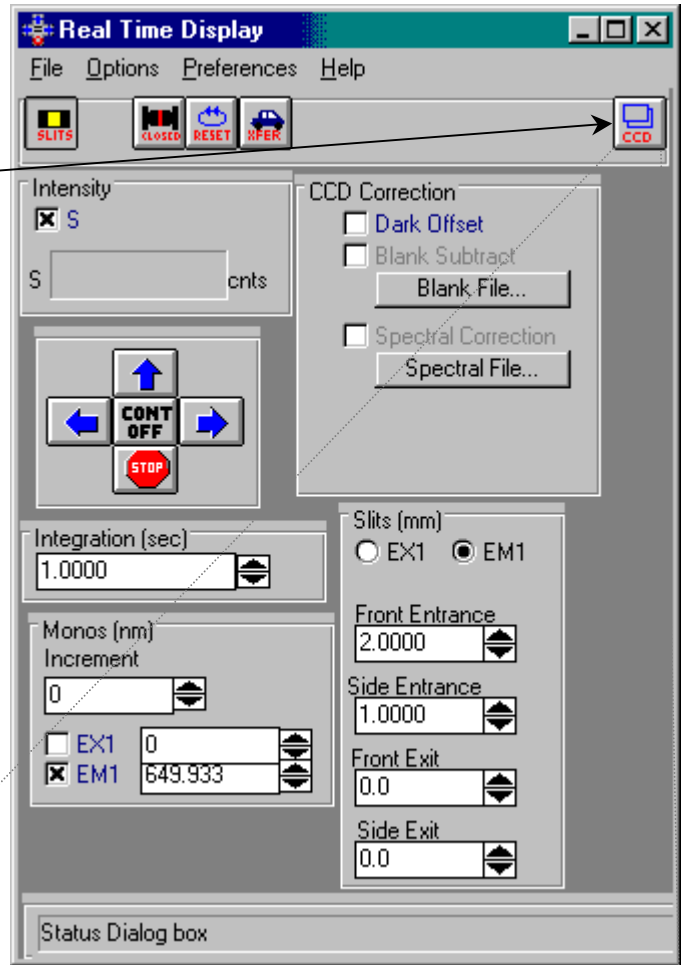

2 The Area List window opens.

Chip Height and Chip Width

This shows the size of the active area, using a choice of units.

Areas Definitions and Areas Views

These index-card tabs give details about which pixels are active, mathe-

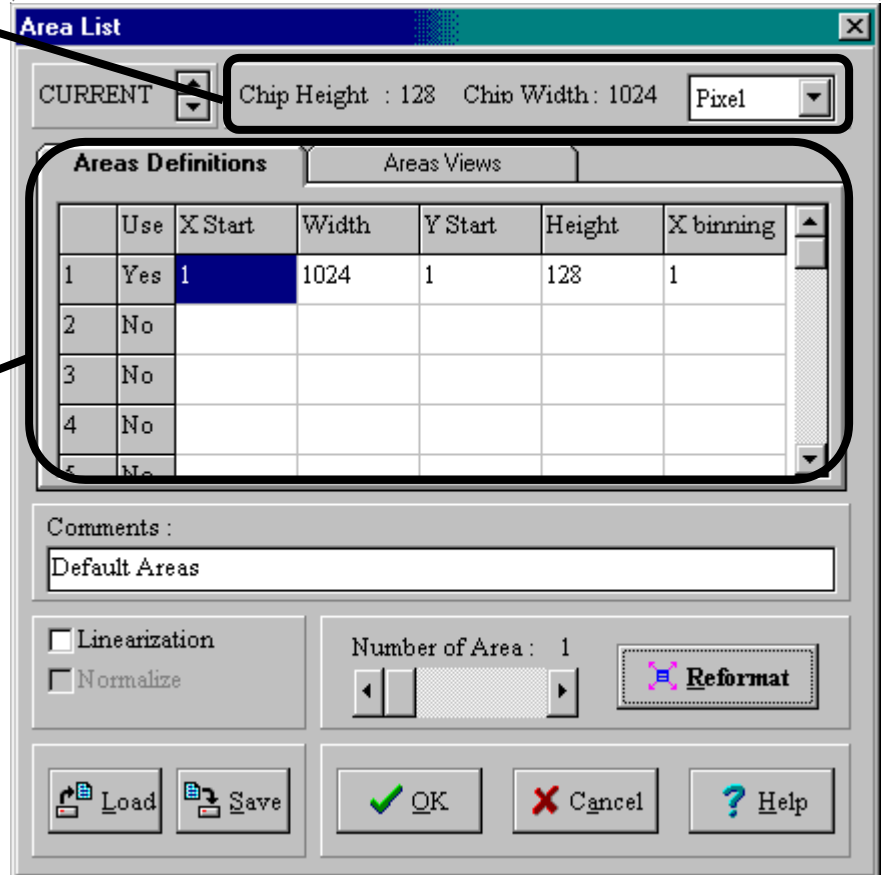

matically (Areas Definitions) and graphically (Areas Views).

Comments:

Unlimited amount of information may be entered, but only the first 80 characters are displayed.

Linearization

Normally, data are taken as pixel number versus intensity. The Linearization checkbox lets the user convert to desired units versus intensity, applying linearization corrections.

Normalize

Visible only with two or more active areas,

Normalize lets the user choose an area as the normalization standard. DataMax performs a Dark Subtract on all data, then divides all areas by the normalization standard.

Reformat

Reformat divides the entire CCD chip equally (to within 1 pixel) into the value shown in the Number of Areas slider. If Number of Areas is 1, then the entire CCD is used as one area. In Image mode, only one area is allowed. Changes are shown in the Areas Definitions.

Load and Save

Load and Save custom CCD-area descriptions for later use, with an .arl extension.

3 Adjust all parameters as desired.

4 Click OK.
The **Areas List** closes.

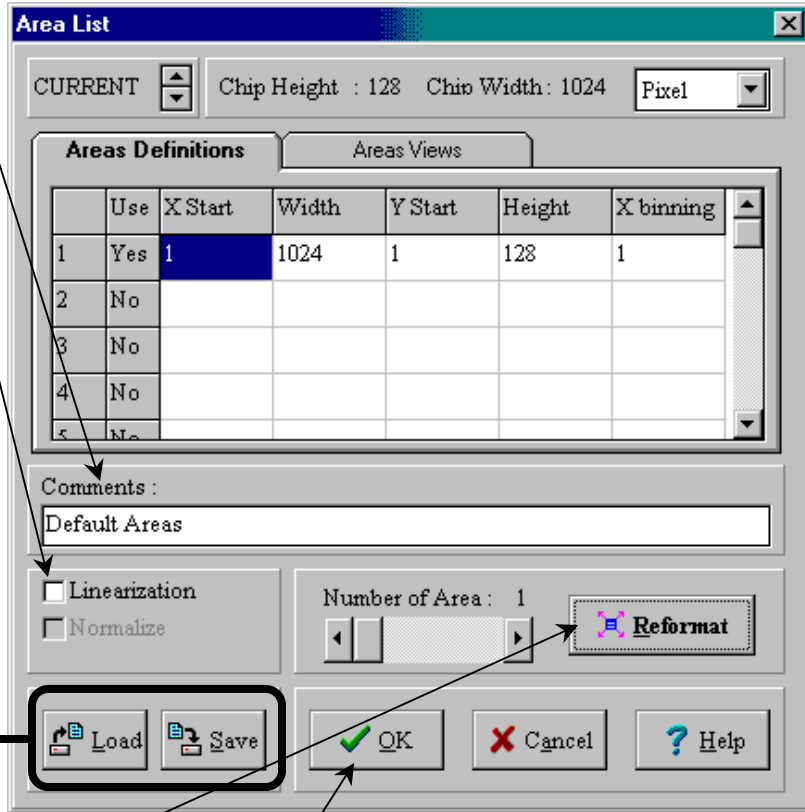

Correcting data with the TRIAX

Introduction

General comments about data correction are found in Chapter 4: *Optimizing Data Acquisition*. This section deals with the procedures that are different when using the TRIAX.

Correction-factor file names for multiple gratings

When the Fluorolog®-3 uses a TRIAX (which contains multiple gratings) or multiple detectors, multiple correction-factor files are required. Each of these has a unique file name, which needs deciphering. Following are rules to guide the correct choice of correction-factor files.



Note: Upper- or lower-case characters are not important.

- 1 The first two characters show the type of correction-factor file.

MC = emission correction-factor file

XC = excitation correction-factor file

- 2 After MC, the next several characters determine the appropriate detector:

2658 = near-IR detector

CD = CCD array



Note: Ignore this rule for XC... files.

928 = R928P photomultiplier tube

DSS = InGaAs detector

- 3 The next one or two characters give the grating's groove-density:

15 = 150 grooves/mm

12 = 1200 grooves/mm

6 = 600 grooves/mm

3 = 300 grooves/mm

- 4 Then comes a separator, x.

- 5 Finally, the last characters show the blaze of the grating:

300 = 300 nm

330 = 330 nm

500 = 500 nm

750 = 750 nm

etc.

Here are some examples of deciphering the emission correction-factor file:

Mcorrect.spc	The default emission correction-factor file for an instrument, with no TRIAX, with only one emission grating and detector.
MC9286x300.spc	An emission correction-factor file for an R928P PMT, with a grating of 600 grooves/mm and a blaze at 300 nm.
MCCD12x500.spc	An emission correction-factor file for a CCD array, with a grating of 1200 grooves/mm and a blaze at 500 nm.
MC26586x300.spc	An emission correction-factor file for an IR detector, with a grating of 600 grooves/mm and a blaze at 300 nm.
Xcorrect.spc	The default excitation correction-factor file for an instrument, with no TRIAX with only one excitation grating.
XC12x330.spc	An excitation correction-factor file for a grating with 1200 grooves/mm and a blaze at 330 nm.



Warning: For CCD arrays, these correction-factor files are only valid under the same conditions, i.e., when used at the same central wavelength as performed in the factory. The files may give invalid corrections when used at other central wavelengths on the CCD array.

To determine the center wavelength for a particular correction-factor file when used with a CCD array, see the Performance Test Report that accompanies the instrument.



Warning: DataMax only uses and displays the first 8 characters of a file name. Therefore, the rest of a correction-factor file name may be truncated, indicated by a tilde (~).

During acquisition

To acquire corrected emission data automatically, enter the appropriate emission correction-factor file, mc..., in the Correction factor file field in the **Run Experiment** dialog box. To acquire corrected excitation data, enter the appropriate excitation correction-factor file, xc....



Note: Before applying correction factors, Jobin Yvon Inc. recommends subtracting the dark counts, and the spectrum of the blank, from the data. Refer to the software manual for details.

After acquisition

To apply the correction factors after the data have been acquired, multiply the data file by the appropriate correction factor file (mc... or xc...).

- 1 Make sure the trace to be corrected is active in the **Run Experiment** window.

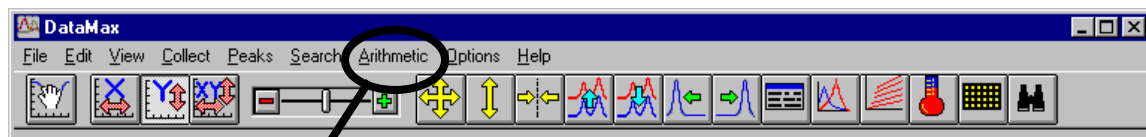

- 2 Choose Arithmetic from the toolbar.

- 3 Choose Functions.

The **Math Functions** dialog box opens:

- 4 Next to Function, select Multiply.

- 5 Next to Operand, choose Term File*K.

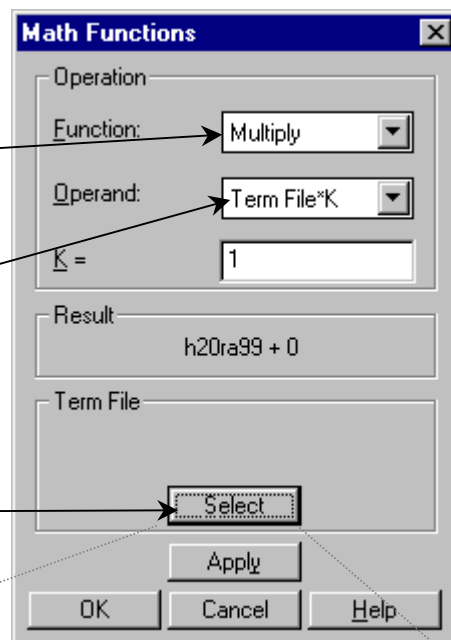

- 6 Click Select.

This opens the **Select New Term File:** dialog box:

- 7 Choose the appropriate file (mc... or xc...).

- 8 Click OK.
The **Select New Term File:** dialog box closes. The file name appears in the Term File area.

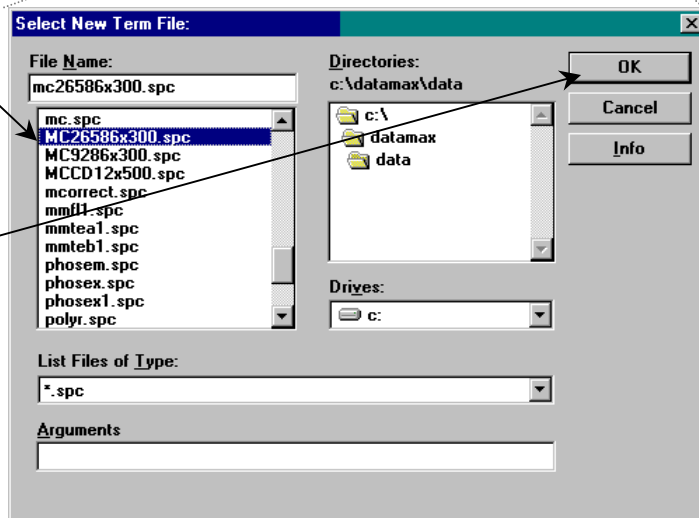

- 9 Click Apply.

The trace that appears on the screen is a result of the mathematical operation, giving a corrected spectrum.

TRIAX 320 Specifications

Focal length	0.32 m
Entrance-aperture ratio	<i>f</i> /4.1
Grating size	68 mm × 68 mm
Image magnification at exit	1.00
Scanning range	0–1500 nm (with 1200-grooves/mm grating)
Multichannel coverage	79.2 nm over 30-mm array width (with 1200-grooves/mm grating)
Focal plane	30 mm wide × 12 mm high
Spectral dispersion	2.64 nm/mm nominal (with 1200-grooves/mm grating)
Spectral resolution	0.06 nm nominal (with 1200-grooves/mm grating), when scanning as a monochromator
Wavelength accuracy	±0.3 nm
Wavelength repeatability	±0.06 nm
Step size	0.06 nm (with 1200-grooves/mm grating)
Dimensions	16.25" long × 15.25" wide × 7.5" high 41.3 cm long × 38.7 cm wide × 19.1 cm high
Weight	40.7 lb (18.5 kg)

Troubleshooting

Should there be a problem with the TRIAX spectrograph, check the following chart for possible problems. Try the remedies listed on these pages before contacting Spex® Fluorescence Service.

Problem	Possible Cause	Remedy
Spectrograph does not respond to any commands	Spectrometer is off.	Check AC outlet (mains), power switch, and fuse.
	Cables are improperly connected.	Check external cable connections.
	Internal cables are not connected.	Check internal ribbon cables, and jumpers on circuit boards.
	Software is inappropriate.	Check that system software matches the hardware.
Spectrograph responds to some commands, but not all	Improper parameters used with correct command.	Check that the failing command is valid, and that parameters are within correct limits for that function.
	Software is inappropriate.	Exit DataMax. Check that the software matches the hardware, especially device configuration.
Slit and wavelength drives and accessories do not move	Bad electrical connection.	Test turret as follows: <ol style="list-style-type: none"> 1 Exit DataMax. 2 Disconnect power. 3 Remove top cover of TRIAX. 4 Gently move turret partway through its range of movement. 5 Reconnect power. 6 Turret should automatically return to home position. 7 Check control-cable connections and interface.
Background signal is too high	Light leak.	Make sure all covers are in place.
		Be sure that the are between the sample and the entrance slit is enclosed and light-tight. Test by blocking the entrance slit.
		Check detector mounting and housing for light leaks.
		Test for stray light: <ol style="list-style-type: none"> 1 Start at detector, close exit and entrance slits and shutters in order. 2 Be sure all openings and screw holes are plugged. 3 Check that the cover, side, and baseplate fit tightly. 4 In a dark room, shine small flashlight at a suspicious part or joint, and observe detected signal levels.
Signal is too noisy	Signal is too weak.	Try to increase signal strength at the detector.



Note: To prevent damage to the knife-edges, the slits never close completely. Therefore some light always enters.

Light leak.

Follow directions above for detecting light leaks.

Improper grounding.

- 1 Exit DataMax.
- 2 Turn off spectrometer.
- 3 Rearrange power connections so that spectrograph, source, and detector are connected to the same ground (earth), and if possible, the same power circuits.
- 4 Add redundant grounds (earths) to various points in the system.



Note: Ground loops often are difficult to diagnose and cure. Experiment patiently. Keep ground wires short, make tight connections, and avoid coated surfaces.

Consider a “star” ground (earth) of wires radiating from a single central location, e.g., a grounded metal table surface under the system.

Electromagnetic interference from lasers or other high-energy apparatus

Construct a faraday cage or shield.

“Warning! Connect Failed (7)” error message appears

CCD-3000 or 3500 controller is off.

Exit DataMax, turn on CCD controller, and restart DataMax.

15: Technical Specifications

Each Fluorolog[®]-3 system consists of:

- An excitation source
- An excitation spectrometer
- A sampling module with reference detector
- At least one emission spectrometer
- At least one emission detector.

Each system is controlled by an IBM-PC-compatible computer, and may include a printer for hard-copy documentation.

Important

The Fluorolog[®]-3 spectrofluorometer system is designed to comply with the requirements of the Low Voltage Directive 73/23/EEC and the EMC Directive 89/336/EEC and, as of 1 January 1997, carries the CE marking accordingly. The system was tested using standard (Jobin-Yvon-Inc.-authorized) components, cables, etc.

The details and specifications for each component of the Fluorolog[®]-3 series of spectrometers follow.

Spectrofluorometer system

The Fluorolog[®]-3 spectrofluorometer consists of modules and components controlled by the specialized software. Although the system can be configured in various ways for a variety of applications, the basic (standard) Fluorolog[®]-3 spectrofluorometer system consists of the following components:

Excitation Source 450-W xenon short arc, mounted vertically in an air-cooled housing. Light collection and focusing by an off-axis mirror for maximum efficiency at all wavelengths.

Optional pulsed lamp or laser port interface available.

Spectrometers Single-grating excitation and emission spectrometers (standard). Spectrometers are Czerny-Turner design with kinematic classically-ruled gratings and all-reflective optics.

The following specifications are based on 1200-grooves/mm gratings:

Resolution	0.2 nm
Accuracy	±0.5 nm
Speed	150 nm/s
Range	0–1300 nm
Gratings*	
<i>Excitation</i>	<i>330-nm blaze (200–700 nm range)</i>
<i>Emission</i>	<i>500-nm blaze (300–1000 nm range)</i>

***Other gratings available for ranges above 1 μm.**

Optional double-grating units available for highest stray-light rejection and sensitivity.

Sample Module T-format sample module with excitation reference detector. The T-box design allows a second emission-detection channel to be incorporated. The sample module also has a removable gap-bed assembly for sampling accessory replacement.

Optional front-face collection assembly available.

Detectors Calibrated photodiode for excitation correction from 240–1000 nm. Emission detector is an R928P for high sensitivity in photon-counting mode (240–850 nm).

Other PMTs to 1100 nm, with thermoelectrically cooled option. Solid-state detectors for higher wavelength emissions. CCD multichannel detector for instant emission spectra and sample spatial information.

Lifetime Option

Lifetime range: 10 picoseconds to 10 microseconds
Frequency range: 0.2 to 310 MHz.

Sensitivity

Double-distilled deionized ICP-grade water Raman scan 4000:1
S/N at 397 nm, 5-nm bandpass, 1 s integration time, background
noise first standard deviation at 450 nm.

Minimum computer requirements

- Pentium III 90 MHz
- 64 megabytes memory (more is recommended)
- Minimum 4-gigabyte hard drive
- SVGA display card and SVGA monitor to match display card
- At least one 3½" high-density floppy drive
- CD-ROM drive
- 101-key enhanced keyboard
- Mouse is strongly recommended
- 2 COM ports *minimum* (1 for communication, 1 for plotter)
- Windows™



Note: Additional COM ports may be required to control accessories such as the MicroMax, temperature bath, etc.

Software

DataMax software for data acquisition and manipulation through the Windows™ environment.

16: Glossary

3D excitation/emission display	This maps a specified emission-scan wavelength range using various excitation wavelengths.
3D synchronous/offset scan	A scan that maps a specified synchronous scan using various offset wavelengths between the spectrometers.
Absorption	Transition, when a photon enters a molecule, from the ground state to the excited singlet state. This process typically occurs in $\sim 10^{-15}$ s.
Absorbance	The extent of absorption by a substance. Absorbance, A , is $-\log T$, where T is the transmittance of the sample. Absorbance is also synonymous with optical density (OD). Absorbance can be calculated using the Beer-Lambert Law: $OD = A = \epsilon cl = -\log T$ $\epsilon = \text{the extinction coefficient (} M^{-1} \text{ cm}^{-1}\text{)}$ $c = \text{sample concentration (} M\text{)}$ $l = \text{path length (cm)}$
Bandpass	The wavelength range of light passing through the excitation and emission spectrometers. The wider the bandpass, the higher the signal intensity.
Bandpass filter	Optical element that selectively transmits a narrow range of optical wavelengths.
Bioluminescence	Emission of light originating from a chemical reaction in a living organism.
Blaze wavelength	Wavelength at which a grating is optimized for efficiency. Generally, the gratings are efficient to 2/3 before the blaze wavelength to twice the blaze wavelength. The excitation and emission gratings are blazed in the UV and visible respectively.
Chemiluminescence	Emission of light originating from a chemical reaction.
Color effect for pulse technique	Time-dependent wavelength distribution of the lamp pulse.
Color effect for phase-modulation technique	Phase of the excitation and the degree to which it is modulated.
Corrected emission scan	An emission scan corrected for the wavelength characteristics of the emission spectrometer and the response of the signal detector. To obtain a corrected emission scan, an emission spectrum is multiplied by the emission correction factors. A set of emission correction factors is supplied with the instrument and stored as <code>mcorrect.spt</code> on the software disks.
Corrected excitation scan	An excitation scan corrected for the wavelength characteristics of the xenon lamp, the aging of the xenon lamp, and the gratings in the excitation spectrometer. To obtain a corrected excitation scan, the de-

tector signal is ratioed to the reference signal, which provides 90% of the corrected excitation scan. To obtain a completely correct scan, the excitation scan acquired in the manner described above is multiplied by correction factors. A set of excitation correction factors is included on the software disks.

Correction factors

Compensates for the wavelength-dependent components of the system, like the xenon lamp, gratings, and signal detector. Emission and excitation correction factors are included with the software and are titled `xcorrect.spt` and `mcorrect.spt`.

Cut-on filter

Optical component that passes light of a higher wavelength.

Cut-off filter

Optical component that passes light of a lower wavelength.

Dark counts

Inherent background signal of the photomultiplier when high voltage is applied. Cooling the detector decreases the dark counts.

Demodulation

(less modulation) Usually refers to the demodulated emission relative to the excitation.

Demodulation factor

Can be calculated using the following equation:

$$m = \frac{AC_f / DC_f}{AC_x / DC_x}$$

where AC_f is the amplitude of the emission voltage, DC_f is the excitation offset voltage, AC_x is the amplitude of the excitation voltage, and DC_x is the offset of the emission voltage.

Emission scan

Shows the spectral distribution of light emitted by the sample. During an emission scan, the excitation spectrometer remains at a fixed wavelength while the emission spectrometer scans a selected region.

Energy transfer

The transfer of the excited energy from a donor to an acceptor. The transfer occurs without the appearance of a photon and is primarily a result of dipole-dipole interactions between the donor and acceptor.

Excitation scan

Shows the spectral distribution of light absorbed by the sample. To acquire an excitation scan, the excitation spectrum scans a selected spectral region while the emission spectrum remains at a fixed wavelength.

Extrinsic fluorescence

Inherent fluorescence of probes used to study non-fluorescent molecules.

Flash lamp

A lamp that provides pulsed-light output used to excite a sample. Can be either "free running" or "gated."

Fluorescence

The emission of light or other electromagnetic radiation during the transition of electrons from the excited singlet state to the ground state. Fluorescence typically occurs within about $\sim 10^{-9}$ s.

Fluorescence lifetime

The average length of time that a molecule remains in the excited state before returning to the ground state.

Front-face detection	A mode of detection in which fluorescence is collected off the front surface of the sample. Front-face detection usually is selected for samples such as powders, thin films, pellets, cells on a cover-slip, and solids.
Grating	Optical element in the spectrometer, consisting of finely scribed grooves that disperse white light into a spectrum.
Intrinsic fluorescence	The natural fluorescent properties of molecules.
Laser	A monochromatic light source that provides high excitation intensity.
Mercury lamp	Light source that emits discrete, narrow lines as opposed to a continuum. A mercury lamp can be used to check the spectrometer calibration.
Mirror image rule	When the emission profile appears to be the mirror image of the absorption spectrum.
Modulated light	Light whose intensity varies in a sinusoidal manner, with a specified frequency.
Optical density	A synonym of <i>Absorbance</i> . See <i>Absorbance</i> .
Optical-density effects	Fluorescence intensities are proportional to the concentration over a limited range of optical densities. High optical densities can distort the emission spectra as well as the apparent intensities.
Phase angle	The delayed relationship between the modulated emission relative to the excitation.
Phase-modulation method	A technique for measuring fluorescence lifetimes, where a sample is excited with light whose intensity is modulated sinusoidally. The emission is a forced response to the excitation.
Phosphorescence	The emission of light or other electromagnetic radiation during the transition of electrons from the triplet state to the ground state. Phosphorescence is generally red-shifted relative to fluorescence and occurs within $\sim 10^{-6}$ s to several seconds. To enhance phosphorescence detection, samples are often chilled to liquid-nitrogen temperature (77 K).
Pockels cell	A light modulator that transmits ultraviolet and visible light, and can be operated at variable frequencies. Highly collimated excitation light is required.
Pulse-sampling method	A technique for measuring fluorescence lifetimes, in which an initial population of fluorophores is excited by infinitely short pulses of light. An advantage of this technique is the direct recording of time-resolved emission spectra.
Raman scattering	Scattering caused by vibrational and rotational transitions. Raman bands generally appear red-shifted relative to the incident electromagnetic radiation. The primary characteristic of Raman scatter is that the difference in energy between the Raman peak and the inci-

	dent radiation is constant in energy units (cm^{-1}).
Rayleigh scattering	Light scattering from particles whose dimensions are much smaller than the wavelength of incident light. The scattered light is of the same energy as the incident light. Rayleigh scatter shows scatter radiation intensity inversely proportional to the 4 th power of the wavelength of incident radiation.
Rayleigh-Tyndall scattering	Combination of Rayleigh and Tyndall scatter. These two scattering phenomena cannot be separated. If the molecule's Stokes shift is small, Rayleigh-Tyndall scatter will limit the ultimate resolution.
Red-sensitive photomultiplier	A detector that extends fluorescence detection to 850 nm.
Reference photodiode	Detector used to monitor the output of the xenon lamp.
Resolution	The ability to separate two closely spaced peaks. Resolution can be improved by decreasing the bandpass and the increment (step size).
Right-angle detection	Collection of fluorescence at 90° to the incident radiation. Right-angle detection typically is selected for dilute and clear solutions.
Scatter	A combination of Raman, Rayleigh, and Rayleigh-Tyndall scattering, which can distort fluorescence spectra with respect to intensities and wavelengths.
Signal photomultiplier	Detector used to measure excitation and fluorescence from the sample. It is operated in the photon-counting mode of detection to provide high sensitivity. Different detectors cover different wavelength regions.
Singlet state	The spin-paired ground or excited state. The process of absorption generally produces the first excited singlet state that emits fluorescence, or undergoes intersystem crossing to form a triplet state.
Spectrometer	The component in a fluorometer system that is scanned to provide the excitation and emission spectra. The spectrometer is chosen for stray-light rejection, resolution, and throughput.
Stokes shift	Generally, the energy-difference between the absorption peak of lowest energy and the fluorescence peak of maximum energy.
Synchronous scan	Scan that characterizes the overlap between the excitation and emission. The excitation and emission spectrometers are scanned at the same time, with a constant offset specified as either nanometers (wavelength units) or in cm^{-1} (energy units).
Time-base scan	Scan in which the sample signal is monitored while both the excitation and the emission spectrometers remain at fixed wavelengths. Time-base data are used to monitor enzyme kinetics, dual wavelength measurements, and determine the reaction rate constant.
Time-resolved emission scan	Scan in which the emission spectra are acquired at various times after the excitation pulse. Provides insight into excited state reactions, charge-transfer-complex formation, solvent dipolar relaxation and

	other experiments.
Triplet state (T_1)	The spin-paired ground or excited state formed from the excited singlet state when paired electrons become unpaired. The triplet state emits phosphorescence.
Tyndall scattering	Scatter that occurs from small particles in colloidal suspensions.
Xenon lamp	Lamp that produces a continuum of light from the ultraviolet to the near-infrared for sample excitation.
Xenon-lamp scan	A profile of the lamp output as a function of wavelength. The lamp scan is acquired with the reference detector while scanning the excitation spectrometer. The maximum xenon-lamp peak at 467 nm can be used to determine proper calibration of the excitation spectrometer.

17: Bibliography

P.M. Bayley and R.E. Dale, *Spectroscopy and the Dynamics of Molecular Biological Systems*, Academic Press, London, 1985.

R. Becker, *Theory and Interpretation of Fluorescence and Phosphorescence*, Wiley-Interscience, 1969.

B. Berlman, *Handbook of Fluorescence Spectra in Aromatic Molecules*, Vols. I & II, Academic Press, New York, 1965 & 1971.

C.R. Cantor and P.R. Schimmel, *Biophysical Chemistry*, Freeman, New York, 1980.

M. Chalfie, *Green Fluorescent Protein: Properties, Applications, and Protocols*, Wiley-Interscience, New York, 1998.

R.F. Chen, *et al.*, *Biochemical Fluorescence: Concepts*, Vol. I & II, 1964 & 1970.

J.N. Demas, *Excited State Lifetime Measurements*, Academic Press, New York, 1983.

Enrico Gratton, David M. Jameson, and Robert D. Hall, "Multifrequency Phase and Modulation Fluorometry," *Ann. Rev. Biophys. Bioeng.* **13**, 105–124 (1984).

G.G. Guilbault, Ed., *Fluorescence—Theory, Instrumentation and Practice*, Marcel Dekker, New York, 1976.

_____, *Practical Fluorescence: Theory, Methods and Techniques*, 2nd ed., Marcel Dekker, 1990.

_____, "Molecular Fluorescence Spectroscopy," *Anal. Chem.* **8**, 71–205 (1977).

D.M. Hercules, Ed., *Fluorescence and Phosphorescence Analysis*, Wiley-Interscience, New York, 1965.

J. Ingle and S. Curch, *Spectrochemical Analysis*, Prentice-Hall, Englewood Cliffs, NJ, 1988.

F.H. Johnson, *The Luminescence of Biological Systems*, Amer. Assoc. Adv. Sci., Washington, D.C., 1955.

S.U. Koney, *Fluorescence and Phosphorescence of Proteins and Nucleic Acids*, Plenum Press, New York, 1967.

M.A. Konstantinova-Schlezinger, Ed. *Fluorometric Analysis*, Davis Publishing Co., New York, 1965.

Joseph R. Lakowicz, *Principles of Fluorescence Spectroscopy*, 2nd ed., Plenum Press, New York, 1999.

_____, Ed., *Topics in Fluorescence Spectroscopy*, Vols. 1–5, Plenum Press, New York, 1991–1998.

_____, Badri P. Melinal, Enrico Gratton, “Recent Developments in Frequency-Domain Fluorometry,” *Anal. Instr.*, **14** (314), 193–223 (1985).

_____, S. Soper, and R. Thompson, *Advances in Fluorescence Sensing Technology IV*, SPIE Proc. Series, Vol. 3602 (1999).

W.T. Mason, Ed., *Fluorescent and Luminescent Probes for Biological Activity: A Practical Guide to Technology for Quantitative Real-Time Analysis*, 2nd ed., Academic Press–Harcourt Brace & Co., 1999.

W.H. Melhuish and M. Zander, “Nomenclature, Symbols, Units and Their Usage in Spectrochemical Analysis VI: Molecular Luminescence Spectroscopy,” *Pure App. Chem.*, **53**, 1953 (1981).

J.N. Miller, Ed., *Standardization & Fluorescence Spectrometry: Techniques in Visible and Ultraviolet Spectrometry*, Vol. 2, Chapman and Hall, 1981.

W.G. Richards and P.R. Scott, *Structure and Spectra of Molecules*, John Wiley & Sons, 1985.

A. Schillen, *et al.*, *Luminescence of Organic Substances*, Hellwege Verlag, Berlin, 1967.

S. Schulman, Ed., *Molecular Luminescence Spectroscopy: Methods and Applications*, Vols. 1–3, Wiley–Interscience, New York, 1985–1993.

A. Sharma and S. Schulman, *Introduction to Fluorescence Spectroscopy*, Wiley Interscience, New York, 1999.

D. Skoog, *Principles of Instrumental Analysis*, 5th ed., Saunders College/Holt, New York, 1998.

N.J. Turro, *Modern Molecular Photochemistry*, Benjamin/Cummings, New York, 1978.

K. Van Dyke, *Bioluminescence and Chemiluminescence: Instruments and Applications*, Vol. 1, CRC Press, Boca Raton, FL, 1985.

T. Vo-Dinh, *Room Temperature Phosphorimetry for Chemical Analysis*, John Wiley & Sons, 1984.

I.M. Warner and L.B. McGowan, Ed., *Advances in Multidimensional Luminescence*, Jai Press, Greenwich, CT, 1991.

E.L. Wehry, Ed., *Modern Fluorescence Spectroscopy*, Vol. 1–4, Plenum Press, New York, 1981.

C.E. White and R.J. Argauer, *Fluorescence Analysis: A Practical Approach*, Marcel Dekker, 1970.

J.D. Winefordner, *et al.*, *Luminescence Spectrometry in Analytical Chemistry*, Wiley-Interscience, New York, 1972.

In addition, the following journals may prove useful:

Analytical Chemistry

Biophysics and Biochemistry

Fluorescence

18: Index

Key to the entries:

Times New Roman font.....	subject or keyword
Arial font.....	command, menu choice, or data-entry field
Arial Condensed Bold font	dialog box
Courier New font.....	file name or extension

I

1,2-propanediol.....	11-15
1908MOD Scatter Block Assembly	6-7, 11-3

3

320M.....	2-11
-----------	------

9

9-CA.....	3-20
-----------	------

A

About Instrument Control Center.....	7-8
accessory	
450-W xenon lamp.....	6-28
absorption/transmission accessory.....	6-3
autotitration injector.....	6-26
CCD detector.....	6-10
cut-on filter.....	6-15
cut-on filter holder.....	6-18
dual-position thermostatted cell holder...	6-21
external trigger accessory.....	6-33, 6-35
fiber optic mount.....	6-14
four-position thermostatted cell holder...	6-19

front-face viewing option.....	6-16
grating.....	6-17
HPLC flow cell.....	6-8
injector port.....	6-33
lamp housing, dual.....	6-25
lamp housing, universal.....	6-25
liquid nitrogen dewar.....	6-6
liquid nitrogen dewar assembly.....	6-6
micro cell (with Model 1923A adapter) ...	6-8
micro cell (with Model 1924A adapter) ...	6-8
microscope interface.....	6-27
microwell plate reader.....	6-31
Peltier thermocouple drive.....	6-29
phosphorimeter.....	6-30, 10-6
photodiode reference detector.....	6-9
polarizer.....	6-32
quartz cuvette.....	6-8
reduced volume sample cell.....	6-8
room temperature signal detector.....	6-11
sample cell.....	6-8
scatter assembly.....	11-2
scatter block assembly.....	6-7
solid sample holder.....	6-23
standard lamp assembly.....	6-7, 11-2
temperature bath.....	6-34
thermoelectrically cooled near-IR signal detector.....	6-13
thermoelectrically cooled signal detector.....	6-12
Accumulations.....	14-11, 14-19, 14-23
Acquisition Channel	14-9
Acquisition Controller – Details	14-9
Acquisition Setup	14-14–16, 14-27–29
adjustment	
lamp procedure.....	5-8
Alconox®.....	4-1
Alternate Lamp.....	6-30
amplitude.....	8-2
analog-digital conversion.....	14-9
anisotropy-decay.....	8-4
anthracene.....	3-20, 4-9
Apply.....	14-37
Area List	14-26, 14-28, 14-33
Areas Definitions.....	14-12–13, 14-33–34

Area List..... 14-12–13, 14-34
Areas Views 14-12, 14-33–34
Arithmetic4-17, 4-20, 11-6, 11-11, 11-13,
 11-18, 14-37
.arl..... 14-13, 14-15–16, 14-34
Auto Adjust..... 14-16
Auto Zero..... 11-1
AutoScale 14-30
axial..... 14-1, 14-32
Axial..... 14-5
azulene 10-2

B

bandpass 3-14, 4-4, 4-13–14, 4-16, 11-5, 14-8
baseplate adapter..... 14-3, 14-39
binning 14-17
Binomial 4-17
biological samples..... 4-2
blank..... 11-6
Blank..... 4-18, 11-1, 11-7
blaze 14-2, 14-35–36
BNC connector..... 13-5
boot disk..... 7-2
Burst..... 14-22

C

cables. 5-1, 5-6, 5-14, 5-1, 7-2, 14-3–4, 14-39
Calc..... 14-29
Calibrate... 3-10, 3-17, 14-7
calibration
 excitation spectrometer 3-9
capillary cell..... 4-2
CAS Number..... 3-20
CCD2-8, 2-12, 14-1, 14-3–4, 14-9–19, 14-
 22–29, 14-31, 14-33–36, 14-40, 15-3
CCD acquisition..... 14-10, 14-31
CCD Acquisition14-10–11, 14-17, 14-22, 14-
 26–29
CCD Areas 14-11–12, 14-26, 14-28
CCD chip14-4, 14-12–13, 14-16–18, 14-33–
 34
CCD controller..... 14-4, 14-9, 14-40
CCD detector ... 14-9, 14-12, 14-14–15, 14-31
CCD icon 14-9
CCD Regions 14-11, 14-14, 14-27–28

CCD shutter 14-4, 14-23
CE marking..... 15-1
Center 14-15, 14-27
center wavelength
 CCD 14-36
Change..... 14-5
Change... 14-6
Chip Height 14-12, 14-33
Chip Width..... 14-12, 14-33
chopper 10-5
circular frequency..... 8-2
Close..... 3-10, 14-5, 14-8
Collect..... 11-16, 14-10, 14-25, 14-31
colloidal silica..... 3-20
COM port..... 7-2
Comments:..... 14-12, 14-34
configurations
 custom 2-9
 standard 2-3
connections, cable..... 13-1
Constant Wavelength Analysis..... 3-2, 4-10
contaminated water..... 7-5–6
Continuous 12-4, 14-22–23
controller..... 2-1
corrected data..... 4-18, 11-1
Correct..... 14-29
Correction..... 4-19, 14-21, 14-36
CORRECTION 11-19
Correction-factor files
 multiple detectors..... 14-35
 multiple gratings 14-35
correction factors 4-18, 11-1
CRE..... 11-10–11
cuvette3-12, 4-1–3, 5-8, 6-4, 6-20, 6-22, 7-5–
 7, 11-15
Czerny-Turner 15-2

D

damage..... 0-4
danger 0-4
dark counts..... 12-1, 12-4, 12-6
Dark Offset..... 4-18
Dark Subtract..... 14-13, 14-34
data
 corrected..... 4-18, 11-1
Data Acquisition Parameters 11-19
data collection methods 4-3

Data Units 14-9
 DataMax0-1, 4-18, 7-8, 8-1, 10-1, 12-3, 14-1,
 14-5, 14-10, 14-13, 14-20, 14-25–26, 14-
 29, 14-31, 14-34, 14-39–40, 15-4
 D-connector 13-2
 Define Experiment 14-26, 14-28
 demodulation 8-2
 Details 14-9
 detector2-4–7, 2-10, 3-3, 3-6, 3-13, 4-4, 4-10,
 4-14, 4-16, 4-18, 5-9, 5-14–15, 6-1, 6-4–5,
 6-7, 6-11–13, 7-1, 7-6, 10-1, 10-4–5, 11-5–
 7, 11-14–15, 14-1, 14-3–4, 14-12, 14-17,
 14-32, 14-35–36, 14-39–40
 dispersion 4-16
 dissolved solids 4-2
 DM302 Photon Counting Module 6-13
 dynamic depolarization 8-4

E

Edit Table 11-11
 Electrical requirements 1-3
Emission Acquisition 3-4, 3-12–13, 4-5, 4-8,
 4-11, 11-6, 11-8–9, 11-16
 emission scan 10-4
 Enable Int. Shutter Move 14-23
Enter Correct Position 3-10, 3-17, 14-7
Entrance Mirror 14-5
 entrance port 14-1, 14-3, 14-5
 environmental requirements 1-2
 europium(III) chloride hexahydrate 3-20
 Excitation Acquisition. 3-4–5, 4-8, 11-16–17
Excitation Acquisition 3-5
 excitation spectrometer
 calibration 3-9
Exit Mirror 14-5
 exit port 14-1, 14-5
 Exp Type... 3-4, 3-12, 4-5, 4-8, 11-8, 11-16
 Experiment 11-6, 11-8, 11-16, 14-10
 exposing
 lamp, the 5-3

F

F-1000/1 Temperature Bath 6-34
 F-3000 Fiber Optic Mount 6-14

F-3004 Sample Heater/Cooler Peltier
 Thermocouple Drive 6-29
 F-3005/6 Autotitration Injector 6-26
 factors, correction 4-18, 11-1
 faraday cage 14-40
 fast-Fourier transform See FFT
Fast Kinetics Mode 14-11, 14-22
 FF 6-24
 FFT 4-17
 filter 6-15, 6-18
 FL-1001 Front-Face Viewing Option 6-16
 FL-1010 Filter Holder 6-15, 6-18
 FL-1011 Four-Position Thermostatted Cell
 Holder 6-19
 FL-1012 Dual-Position Thermostatted Cell
 Holder 6-21
 FL-1013 Liquid Nitrogen Dewar Assembly 6-
 6
 FL-1015 Injector Port 6-33
 FL-1039 Xenon Lamp Housing 6-28
 FL-1040 Dual Lamp Housing 6-25, 6-28
 FL-1044 L-Format Polarizer 6-32
 flash lamp 2-8, 2-12, 6-30
 flip mirror 14-1, 14-5
 fluorescein 3-20, 10-2–3
 fluorescence polarization 10-7
 Fluorescence Service Department .. 5-16, 5-20
 fluoroimmunoassay 10-7
 fluorophore 8-4
 Flush 14-24
 Flush Before Each Acquisition 14-24
 Flush Before First Scan 14-24
 FM-2003 Sample Compartment Accessory 6-
 19, 6-21
 From 14-16, 14-27
 Front 14-32
 front-face data collection 4-3, 10-6
 Functions 4-20, 14-37
 fuse 14-39
 fused silica 4-2, 6-6, 6-8

G

G factor 4-10–12
 G Factor 4-11
 Gain Level 14-9
 glycogen 3-20

grating 4-16, 4-18, 5-8, 5-16–19, 6-7, 6-15, 6-17–18, 10-1, 14-1–2, 14-6–7, 14-15–16, 14-28, 14-35–36, 14-38
 grating factor See *G* factor
 grating icon 14-6
 grating turret 14-1
Grating/Turret 3-10, 3-17, 14-6
 groove density 4-16, 14-2, 14-6, 14-15, 14-35

H

hazardous condition 0-4
 Help 7-8
 Hg lamp 14-26
High Voltage 11-10, 11-17, 12-3, 12-5
 highly scattering samples 10-4
 host computer 0-1, 1-3, 2-1, 3-2, 6-31–32, 12-3, 13-1–3, 13-6, 14-4, 15-1
 humidity level 1-2
 HV 11-10, 11-17, 14-32

I

Image 14-11, 14-13, 14-17, 14-34
 imaging spectrograph 2-9, 2-11
 infrared 10-5
 InGaAs 14-32, 14-35
 inserting
 lamp, the 5-5
 installation 1-4
Instrument Control Center 3-2, 7-2, 7-8
 Int. Time 14-15
 integration time 4-13–14, 5-8, 14-15–16, 14-28–29
 determining optimum 4-14
 Integration Time 3-5, 3-13, 11-6, 12-3, 14-11, 14-18, 14-23
Intensity 14-32
 Intg. time 14-16
 IR detector 14-32, 14-35–36
 IRR 11-11–13
 irradiance 11-2, 11-5, 11-8, 11-10–11
 isamain.ini 7-2
 isascan.set 7-2
 isascan.vw 7-2

L

lamp
 adjustment 5-8
 exposing 5-3
 inserting 5-5
 removing 5-4
 lamp scan 3-5, 3-7, 3-11–12, 5-1, 7-3–4, 7-8, 11-7, 14-7
 lamp.exp 3-5, 3-19
 lamp.spc 3-5
 laser 2-8, 2-12, 14-40
Last Read Out Time 14-23
 lateral 14-1, 14-3, 14-32
Lateral 14-5
 layout 4-11, 14-5, 14-32
Layout Selection 3-2
 LDS 750 3-20
 lifetime 3-20, 8-1–2, 8-4
 lifetime measurements 8-2
 lifetime resolved 8-4
 limit of detection 10-3
 Linearization 14-12, 14-25–26, 14-28, 14-34
Linearization Parameters 14-25, 14-26
Linearization Procedure 14-26
 liquid nitrogen 6-6
 Load 14-13, 14-15–16, 14-34
 lock-in amplifier 10-5
 low-temperature scans 10-6
 LUDOX[®] 3-20

M

magnetic stirrer 4-2, 6-8, 6-19–22
 maintenance 5-1
 detector, reference 5-15
 detector, signal 5-14
 gratings 5-16
 lamp 5-1
 housing 5-12
 replacement 5-1, 5-2
 mirrors 5-20
 mask 11-2
Math Functions 4-20, 14-37
 mcorrect 4-18–20, 11-1–2, 11-13, 14-36
 (Me)₂POPOP 3-20
 meniscus 7-6
 MHV connector 13-5

MicroMax 3-1, 6-2, 6-31
 Microscope Interface 6-27
 mirror icon 14-5
 Mirrors..... 14-11, 14-20
 mm..... 3-6, 6-8
 Model 1630 Field Lens Adapter 6-12
 Model 1692M Selection Mirror..... 5-20
 Model 1914F Thermoelectrically Cooled
 Signal Detector 6-12
 Model 1923 Micro Cell..... 6-8
 Model 1924 Micro Cell..... 6-8
 Model 1933 Solid Sample Holder 4-2-3, 6-23
 Model 1938 Cut-On Filter 6-15, 6-18
 Model 1939 Cut-On Filter 6-15, 6-18
 Model 1908 Standard Lamp Assembly .. 11-2
 Model 1908MOD Scatter Assembly..... 11-2
 Model 1940 Absorption/Transmission Model
 Accessory 6-3
 Model 1976 Accessory Controller..... 7-2
 Model FL3-11 2-4
 Model FL3-12 2-5
 Model FL3-21 2-6
 Model FL3-22 2-7
 Model FL3-XXX 2-10
 Model TRIG-15/25 External Trigger
 Accessory..... 6-35
 models
 Fluorolog-3 2-3
 modulation 8-2, 8-4
 modulation lifetime..... 8-2
 monitor..... 1-3
 monochromator 2-3, 3-2-4, 3-7, 3-9-12, 3-
 16-18, 4-16, 5-17, 7-1-2, 10-5, 11-15, 14-
 1, 14-5, 14-38
 monolayer 4-2, 6-16, 10-6
 Move All 14-8
 Multi Scans/One Peak..... 14-26
 Multiply 4-20, 11-11, 14-37

N

NADH 3-20
 Nb Cover 14-16
 Nb region 14-14
 Nb Region 14-27, 14-29
 Nb Regions 14-27
 near-IR detector 14-35
 neutral-density filter..... 11-2

New Polarization Sample 4-10
New Value 14-6-7
 Nikon 6-2, 6-27
 nitric acid..... 4-1
 nm 3-14
 No Flush 14-24
 no trace view object..... 7-2
 Normalize 14-12-13, 14-34
 Number of Areas..... 14-13, 14-34
 Number of Scans 4-15, 11-6

O

offset..... 8-2, 10-4
 OK14-6-7, 14-9, 14-13, 14-15-16, 14-26-
 29, 14-34
 Olympus 6-2, 6-27
One Scan/Multi Peaks 14-28
Operand 4-20, 14-37
 optics 4-10
 optimum
 integration time 4-14
 optimum wavelengths
 determining 4-3
 options 2-8, 2-12
 custom 2-12
 standard 2-8
Options 3-6, 3-14
 outliers 4-17

P

Peaks/Settings 4-17
 performance test report..... 3-3, 14-36
 phase angle 8-2
 phase lifetime 8-2
 phase shift..... 8-4
 phosphorescence..... 2-2, 3-20, 10-5-6
 photobleach 10-7
 photodiode 2-2, 3-4, 5-15, 6-2, 6-9, 11-14-15
 photomultiplier detector See PMT
 photomultiplier tube See PMT
 plateau voltage..... 12-1, 12-5-6
 PMT2-3, 2-8, 2-12, 3-3, 5-14, 6-2, 6-13, 14-
 21, 14-32
Polar Scan... 4-12
 polarization..... 2-2, 2-10, 4-10

Polarization..... 4-11
 polarizer 4-10-12, 6-32, 7-1, 10-7
Polarizer Settings 4-10
 poor resolution 7-4
 POPOP 3-20
 Position 14-15, 14-27, 14-29
 potassium bromide 4-2
 power supply 5-2, 5-7, 6-1, 6-7, 6-12, 6-25, 7-1, 11-2, 11-5, 14-2
 PPD 3-20
 PPO 3-20
 printer 1-3, 2-1, 3-2
 Proceed to Acquisitions 4-10
p-Terphenyl 3-20

Q

quantum yield..... 4-13, 4-18, 10-4, 11-1
 quartz..... 3-12, 6-2, 6-6-8, 6-23, 11-2
Quick Polarization 4-12

R

R 3-6, 4-18, 6-5
 R928P2-4-7, 3-3, 5-14, 6-11-12, 11-7, 11-14, 15-2, 14-35-36
 RA 3-14, 6-3, 12-3
 radiometric correction 11-1, 11-8
 radiometric correction factors 4-18, 11-1
 Raman 3-3, 3-12-13, 3-15, 3-18-20, 5-1, 5-8-10, 7-5-8, 9-1, 14-7
 Range 14-15-16
 raw polarization 4-10
 Rayleigh scatter 3-15
 re-assembly 1-4, 13-1
Real Time Display 3-2, 3-9, 3-16, 4-4, 4-14, 5-9, 11-3, 11-15-17, 12-3, 14-7, 14-31
 red-sensitive photomultiplier 10-5
 reduced-volume samples 10-3
 reference detector 2-2, 4-18, 8-1, 10-1-2
 reflectance plate 11-2
 Reformat 14-13, 14-26, 14-28, 14-34
 remove
 lamp 5-4
 replacement procedure
 lamp 5-2
 resorufin 10-3

rhodamine-B 11-15
 ribbon cables 14-39
 right-angle data collection 4-3
 rose Bengal 3-20
 RTD-CCD 14-31
 Run. 4-7, 4-9, 11-18, 14-11, 14-23, 14-28-29
Run Experiment 3-2, 3-4, 3-11-12, 3-18, 4-5, 4-8, 4-11, 4-14-15, 4-17, 4-19-20, 5-10, 11-6, 11-8, 11-13, 11-16, 11-18, 14-10, 14-31, 14-36-37

S

S 3-13, 5-8-9, 6-5, 12-3-4
S/N ratio 4-13-15, 6-12, 15-3
 S/R 4-9, 4-18, 6-4-5, 11-15, 11-17
 sample changer 8-1, 11-3
 sample compartment 2-1, 4-4, 11-3-4, 11-15, 14-1, 14-3
 sample mount 14-1
 sample preparation
 biological samples 4-2
 dissolved solids 4-2
 small-volume sample 4-2
 solid samples 4-2
 Save 14-13, 14-15-16, 14-34
 Savitsky-Golay 4-17
 Scan 14-11, 14-14, 14-17
 scanning, multiple times 4-15
 scatter block 11-2
 scatter plate 11-3
 scattering 3-20
 screwdriver 5-1, 5-16
 Select 4-20, 14-37
Select Calibration Peak 14-29
Select Experiment Type 3-4, 3-12, 4-5, 4-8, 11-8-9, 11-16
Select New Term File 4-20, 14-37
 Selected Signal 11-17
 serial number 7-9
 Service Department 1-4, 7-1-2, 7-8-9, 11-2, 14-39
 shutter 5-9, 7-1, 8-1, 11-1, 11-15, 14-39
 Side 14-32
Signals 3-6, 3-13, 4-8-9
 Signals 3-6, 3-13, 4-6, 4-8, 11-10, 11-17
 signal-to-noise ratio *See S/N* ratio
 singlet 10-5

slits 2-4-7, 3-6, 3-14, 4-4, 4-16, 5-8, 5-17, 6-1, 6-4-5, 7-1-2, 7-4, 7-6-7, 8-1, 11-3, 11-5, 11-15, 14-3, 14-8, 14-28-29, 14-32, 14-39

Slits 3-6, 3-14, 4-6, 11-17, 14-8, 14-32

Slits 3-6, 3-14, 4-6, 11-17

small-sample volume 4-2

smoothing 4-17

solid samples 4-2

specifications

 computer 15-4

 software 15-4

 spectrofluorometer system 15-2

TRIAX 14-38

SpectrAcq 3-1, 14-4

standards 3-20

stdlamp 11-6

stdlamp2 11-6, 11-12-13

Styryl 7 3-20

support

 technical 7-8

surface requirements 1-1

symbols 0-4

synchronous scan 6-5, 10-4

system configuration 1-1

system controller 1-3, 13-1, 13-3

T

T-box 2-2-3, 6-14-15, 6-18, 6-32, 10-6, 11-15

Table View 11-10

technical support 7-8

temperature 1-2

temperature bath 3-1, 6-2, 6-19, 6-21, 6-34

Term File 14-37

Term File *K 4-20, 14-37

thin film 4-2, 6-23-24

time-based fluorescence 10-6

Time Increment 14-23

time-resolved 8-4

time-resolved data 10-5

To 14-16

Toolbar 14-32

TRIAX 2-9, 2-11, 14-1-5, 14-8, 14-10, 14-15-16, 14-25, 14-31-32, 14-35-36, 14-39

triplet 10-5

troubleshooting 7-1

troubleshooting, **TRIAX** 14-39

turret 14-2, 14-6, 14-39

U

Units 3-6, 3-14

Use Polarization Modes 4-10

V

ventilation 1-2

View 11-10

Visual Instrument Setup 3-2, 3-6, 3-9-10, 3-14, 3-16-18, 4-14, 7-1, 14-2, 14-5, 14-9

voltage converter 14-2

W

water 3-20

water.exp 3-13, 3-19

water.spc 3-13

wavelengths

 determining optimal 4-3

web site 7-8

Windows™ 0-1, 15-4

X

Xe *See xenon lamp.*

xenon lamp 1-3, 2-2, 3-1, 3-3-5, 3-8, 3-10, 3-12, 3-19, 4-18, 5-1, 5-2, 5-4-5, 6-1, 6-9, 6-25, 6-28, 7-1, 7-3-4, 9-1, 12-3-4, 14-7

xcorrect .. 4-18-20, 11-1, 11-18-19, 14-36

XFER 11-17

Z

Zap 4-17

Zeiss 6-2, 6-27

